

R-VPX EVOLUTION SERIES HIGH SPEED EVOLUTION



Amphenol introduces R-VPX Evolution Module up to 32 Gbps data rate transfer performance.

Evolution is specifically designed to support the latest high speed protocols while still meeting open VPX requirements. Evolution meets the performance requirements of VITA 46 & 47 while still intermateable with existing VITA 46 backplane connectors. These connectors are optimized for speed and ruggedized for harsh environments in military applications.

RVPX EVO

R-VPX EVOLUTION 1.0:

- 16 Gb/s+ Performance
- 4 Point Contact System
- Module connector has modified footprint- utilizes smaller compliant contacts for increased Si performance.
- Backplane connector is the legacy connector- no changes necessary on the backplane.
- Intermateable with existing/legacy VITA 46 connectors
- Footprint compliant with 46.30 (VITA Draft Spec)
- Passed VITA 72 vibration level testing with BER monitoring

R-VPX EVOLUTION 2.0:

- 32Gb/s Performance
- 4 Point Contact System
- Module AND Backplane connectors utilize smaller compliant contacts for increase Si performance
- Intermateable with existing/legacy VITA 46 connectors.
- 46.30 Spec compliant
- Passed VITA 72 vibration level testing with BER monitoring

FEATURES AND BENEFITS

Supports High Speed Protocols

- PCIe Gen 4 and Gen 5
- 1000BASE-KX
- 10GBASE-KX4
- 100GBASE-KR4
- Infiniband SDR, DDR, and QDR
- Serial RapidIO 12.5 Gbaud and 25 Gbaud

EVO 2 SI ELECTRICAL PERFORMANCE

Mated Configuration

RVPX EVO

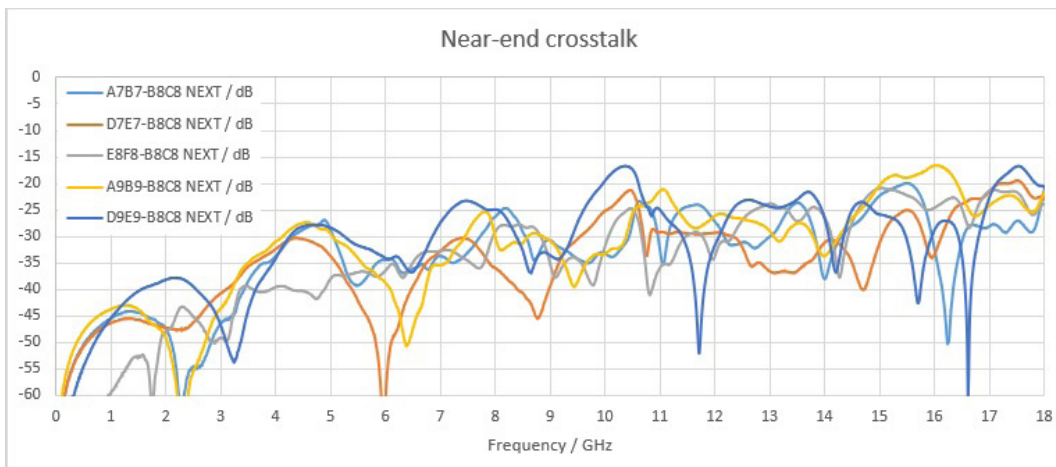
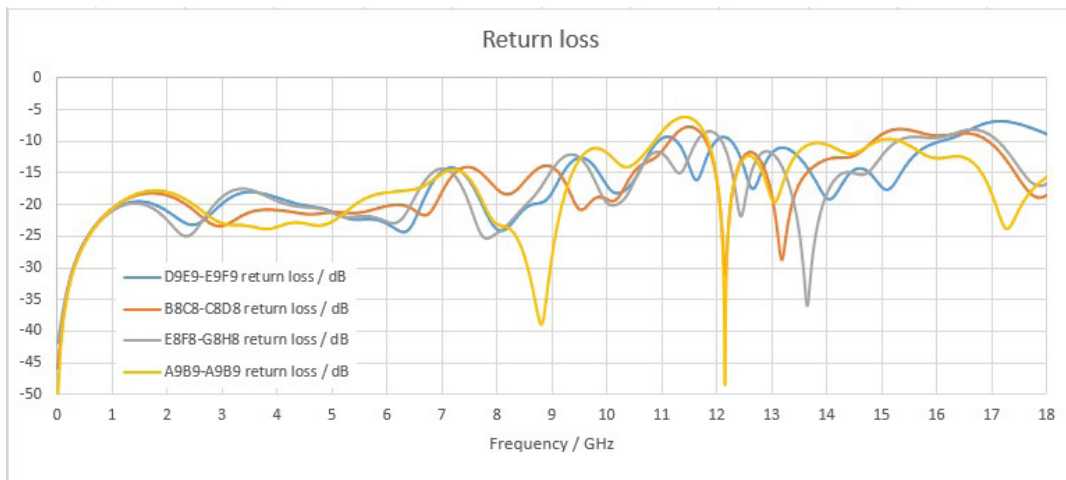
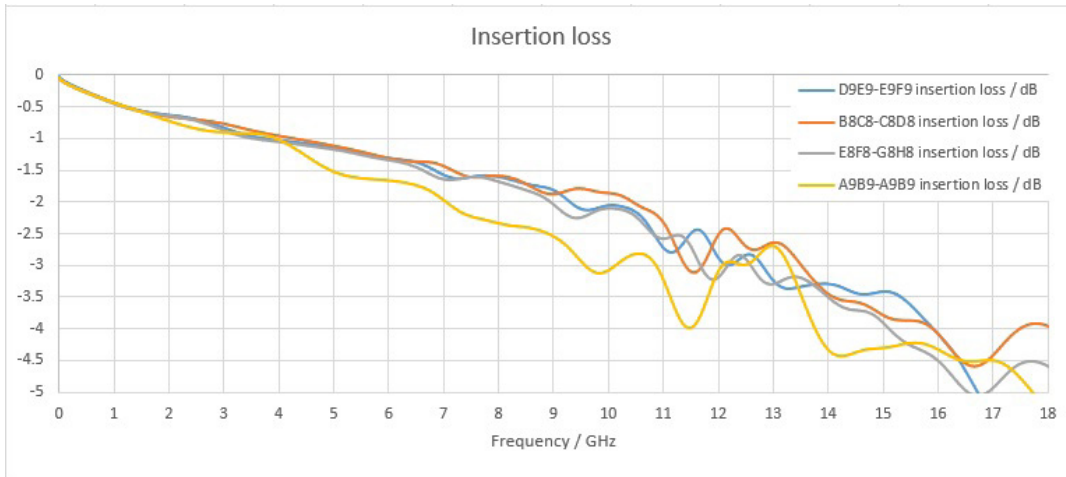

EVO 2 SI ELECTRICAL PERFORMANCE

Eye pattern @ 25.8 Gbps

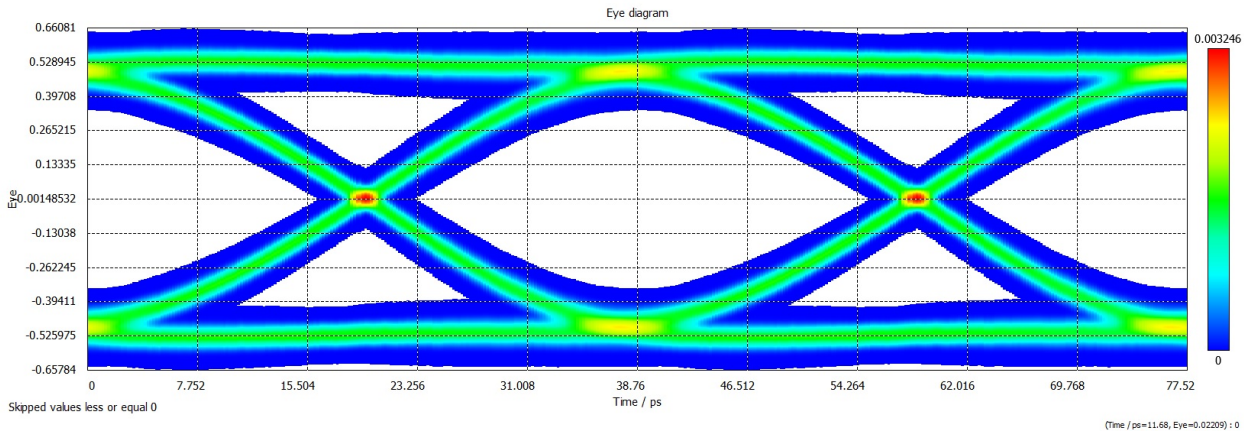

RVPX EVO

Note: PRBS-23 signal through D7E7-E7F7 pair with all surrounding pairs as active aggressors

Eye pattern @ 32 Gbps

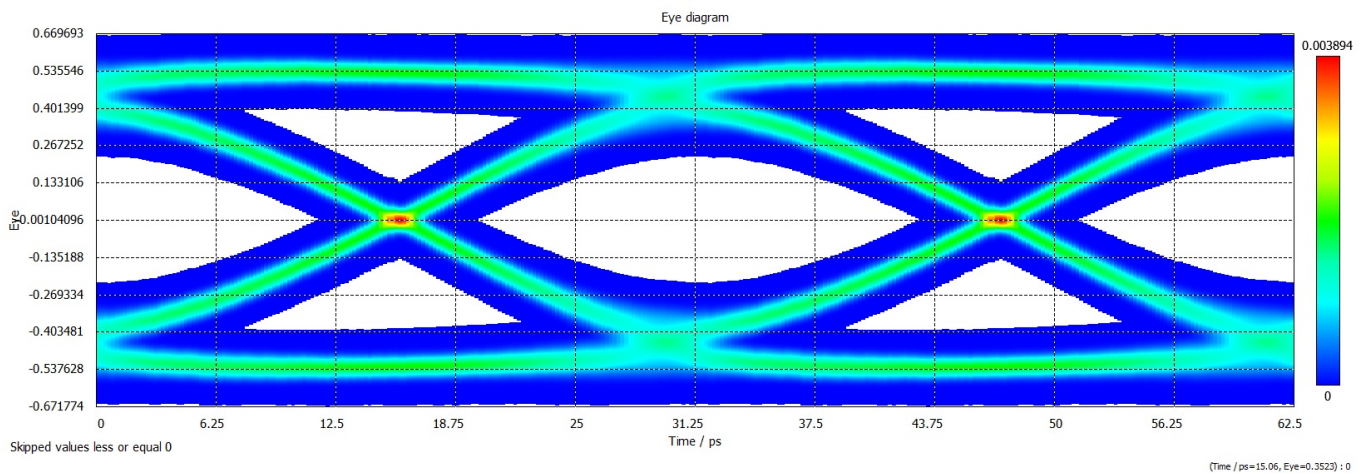

Note: PRBS-23 signal through D7E7-E7F7 pair with all surrounding pairs as active aggressors

R-VPX EVOLUTION SERIES - EVO 1 AND 2 PART NUMBERS

RVPX EVO

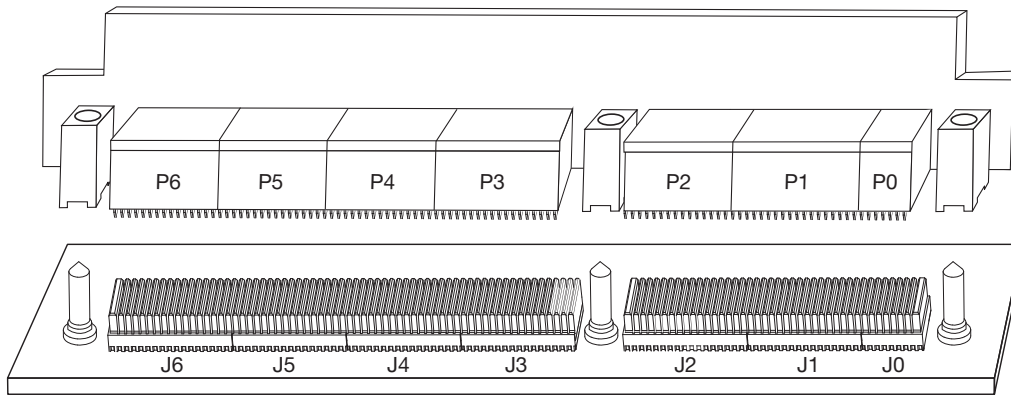

	Part Number	Location	Gold in Contact Area	Compliant Contact Termination Finish	Nickel Overall
EVO 2 8 Pos Module	RVPX-PE208VM1	P0	50 u-inch min.	Tin	50 u-Inch min.
	RVPX-PE208VM2	P0		Tin-Lead	
	RVPX-PE208VC1	P0	30 u-inch min.	Tin	50 u-Inch min.
	RVPX-PE208VC2	P0		Tin-Lead	
EVO 1 16 Pos Module	RVPX-PE16DM1	P1-P6	50 u-inch min.	Tin	50 u-Inch min.
	RVPX-PE16DM2	P1-P6		Tin-Lead	
	RVPX-PE16DC1	P1-P6	30 u-inch min.	Tin	50 u-Inch min.
	RVPX-PE16DC2	P1-P6		Tin-Lead	
EVO 2 16 Pos Module	RVPX-PE216DM1	P1-P6	50 u-inch min.	Tin	50 u-Inch min.
	RVPX-PE216DM2	P1-P6		Tin-Lead	
	RVPX-PE216DC1	P1-P6	30 u-inch min.	Tin	50 u-Inch min.
	RVPX-PE216DC2	P1-P6		Tin-Lead	
EVO 2 8 Pos Backplane	RVPX-JE208EM1	J0	50 u-inch min.	Tin	50 u-Inch min.
	RVPX-JE208EM2	J0		Tin-Lead	
	RVPX-JE208EC1	J0	30 u-inch min.	Tin	50 u-Inch min.
	RVPX-JE208EC2	J0		Tin-Lead	
EVO 2 16 Pos Backplane	RVPX-JE216MM1	J1, J3-J5	50 u-inch min.	Tin	50 u-Inch min.
	RVPX-JE216MM2	J1, J3-J5		Tin-Lead	
	RVPX-JE216MC1	J1, J3-J5	30 u-inch min.	Tin	50 u-Inch min.
	RVPX-JE216MC2	J1, J3-J5		Tin-Lead	
	RVPX-JE216EM1	J2, J6	50 u-inch min.	Tin	50 u-Inch min.
	RVPX-JE216EM2	J2, J6		Tin-Lead	
	RVPX-JE216EC1	J2, J6	30 u-inch min.	Tin	50 u-Inch min.
	RVPX-JE216EC2	J2, J6		Tin-Lead	

R-VPX EVOLUTION SERIES - EVO 2 PART NUMBERS

Hybrid Configurations

Evo 2 Hybrid Configurations					
Part Number	Gender	Rows of Contacts	Insert Type	Plating	Contact Finish
RVPX-PE20817M2	Evo 2 Module	8	P0 V - VITA 46 Hybrid	50 Micro-Inches	Tin-Lead
RVPX-PE21609M2	Evo 2 Module	16	Hybrid PO+P1A	50 Micro-Inches	Tin-Lead
RVPX-PE20817M1	Evo 2 Module	8	P0 V - VITA 46 Hybrid	50 Micro-Inches	Tin
RVPX-PE21609M1	Evo 2 Module	16	Hybrid PO+P1A	50 Micro-Inches	Tin
RVPX-PE20817C2	Evo 2 Module	8	P0 V - VITA 46 Hybrid	30 Micro-Inches	Tin-Lead
RVPX-PE21609C2	Evo 2 Module	16	Hybrid PO+P1A	30 Micro-Inches	Tin-Lead
RVPX-PE20817C1	Evo 2 Module	8	P0 V - VITA 46 Hybrid	30 Micro-Inches	Tin
RVPX-PE21609C1	Evo 2 Module	16	Hybrid PO+P1A	30 Micro-Inches	Tin
RVPX-JE20818M2	Evo 2 Backplane	8	J0 End Hybrid	50 Micro-Inches	Tin-Lead
RVPX-JE21616M2	Evo 2 Backplane	16	Hybrid J0+J1A	50 Micro-Inches	Tin-Lead
RVPX-JE20818M1	Evo 2 Backplane	8	J0 End Hybrid	50 Micro-Inches	Tin
RVPX-JE21616M1	Evo 2 Backplane	16	Hybrid J0+J1A	50 Micro-Inches	Tin
RVPX-JE20818C2	Evo 2 Backplane	8	J0 End Hybrid	30 Micro-Inches	Tin-Lead
RVPX-JE21616C2	Evo 2 Backplane	16	Hybrid J0+J1A	30 Micro-Inches	Tin-Lead
RVPX-JE20818C1	Evo 2 Backplane	8	J0 End Hybrid	30 Micro-Inches	Tin
RVPX-JE21616C1	Evo 2 Backplane	16	Hybrid J0+J1A	30 Micro-Inches	Tin

RVPX EVO

R-VPX EVOLUTION SERIES- EVO 2

DAUGHTER CARD: Right-Angle Plug Assembly, 8 Center

RVPX EVO

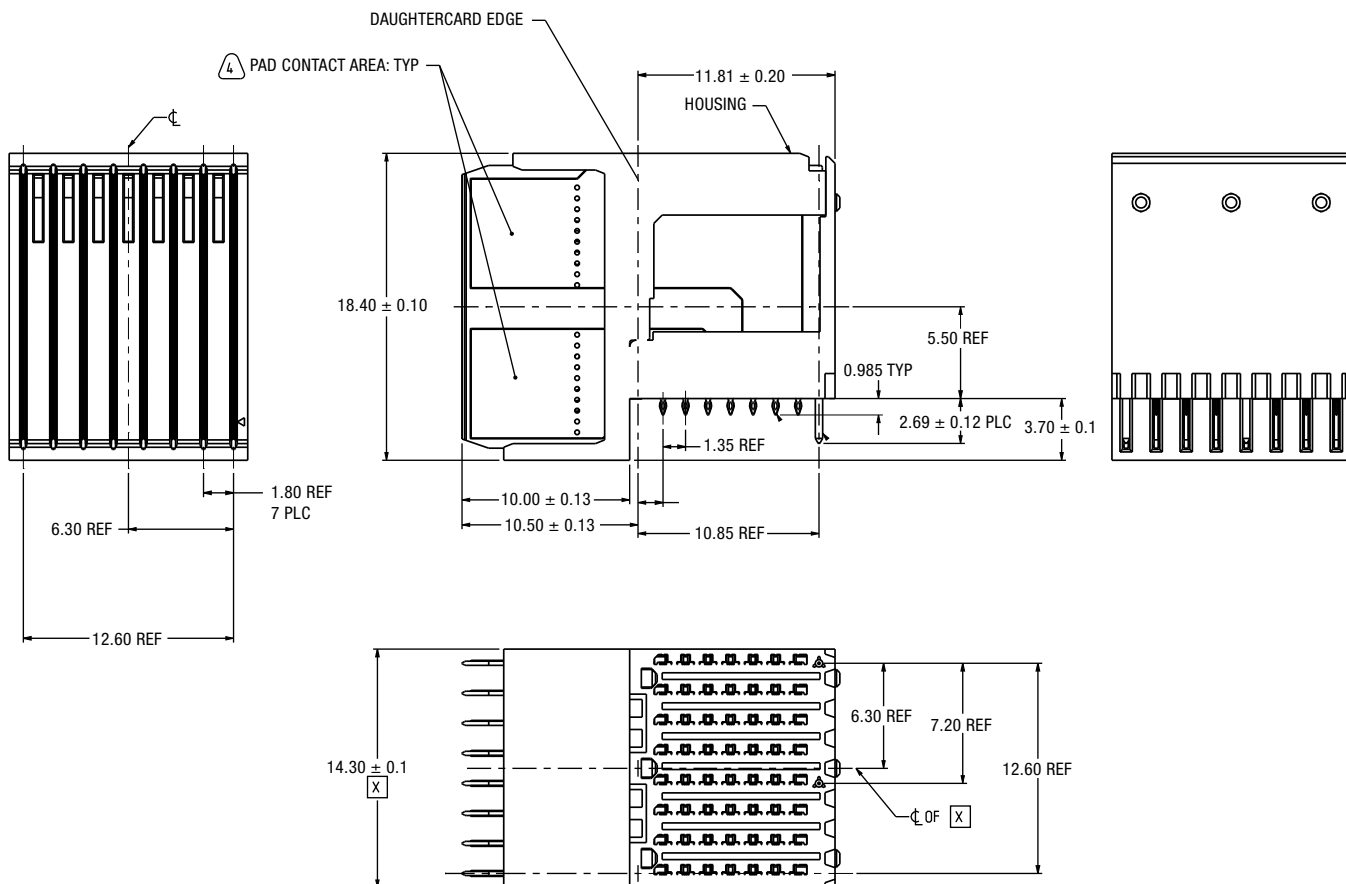

PLATING THICKNESS AND MATERIAL BY PART NUMBER

Part Number	Gold in Contact Area	Compliant	Nickel Overview
RVPX-PE208VM1	1 50 μ-INCH MIN	50 μ-INCH MIN TIN	50 μ-INCH MIN
RVPX-PE208VM2	50 μ-INCH MIN	50 μ-INCH MIN tin	50 μ-INCH MIN
RVPX-PE208VC1	30 μ-INCH MIN	50 μ-INCH MIN tin	50 μ-INCH MIN
RVPX-PE208VC2	30 μ-INCH MIN	50 μ-INCH MIN tin	50 μ-INCH MIN

BACKPLANE EVOLUTION 2: 8 Position Backplane

RVPX EVO

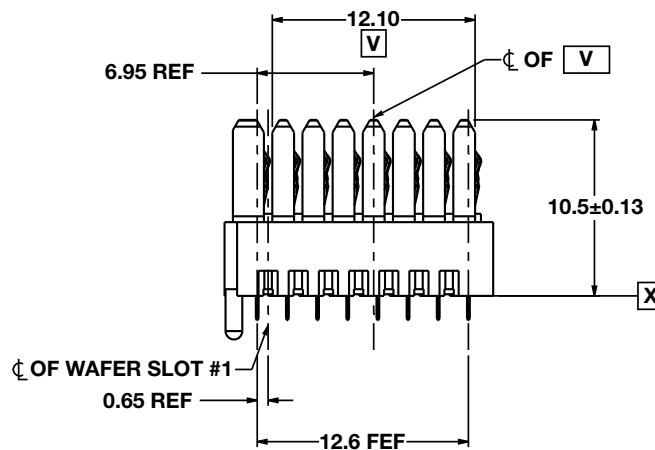
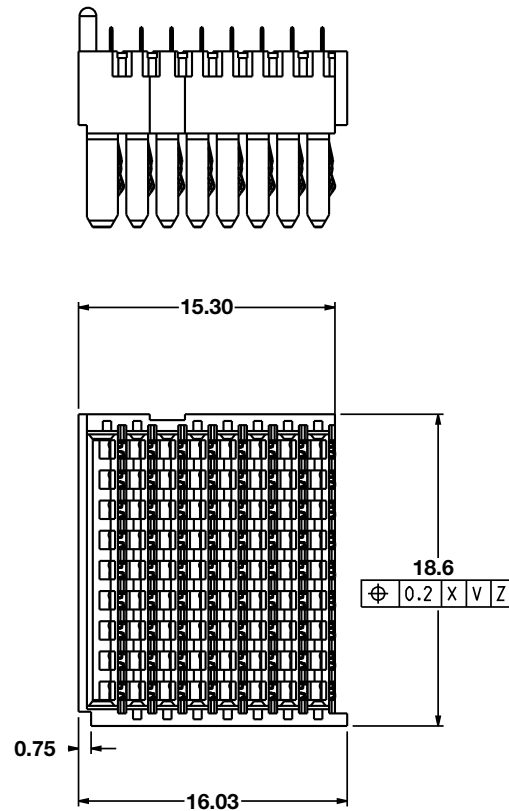
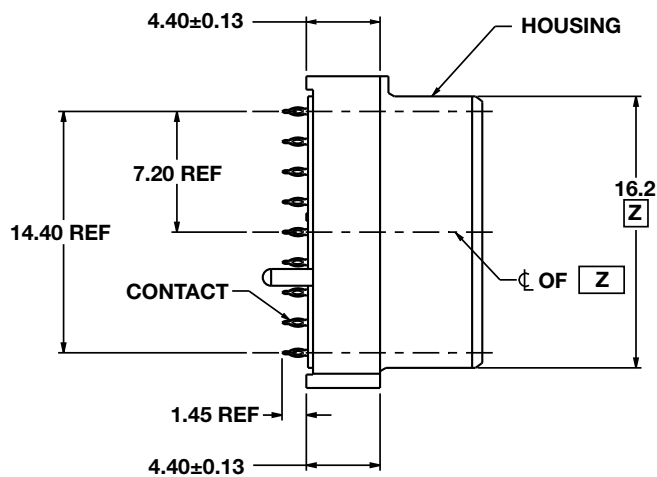

PLATING THICKNESS AND MATERIAL BY PART NUMBER

Part Number	Gold in Contact Area	Compliant	Nickel Overview
RVPX-JE208EM1	50 µ-INCH MIN	50 µ-INCH MIN TIN	50 µ-INCH MIN
RVPX-JE208EM2	50 µ-INCH MIN	50 µ-INCH MIN TIN-LEAD	50 µ-INCH MIN
RVPX-JE208EC1	30 µ-INCH MIN	50 µ-INCH MIN TIN	50 µ-INCH MIN
RVPX-JE208EC2	30 µ-INCH MIN	50 µ-INCH MIN TIN-LEAD	50 µ-INCH MIN

R-VPX EVOLUTION SERIES- EVO 1 & EVO 2

DAUGHTER CARD: Right-Angle Plug Assembly, 16 Center

RVPX EVO

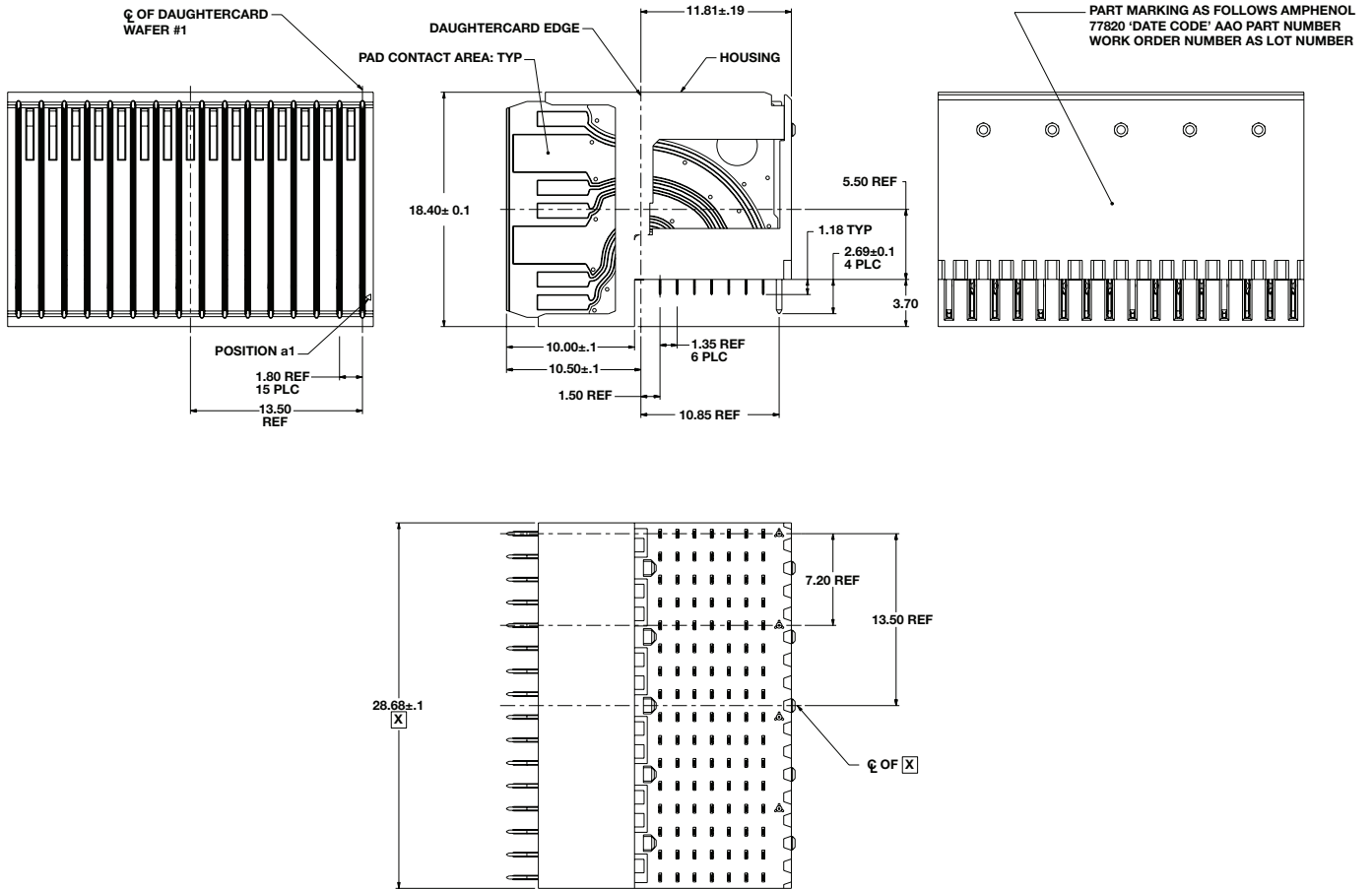

PLATING THICKNESS AND MATERIAL BY PART NUMBER				
	Part Number	Gold In Contact Area	Compliant Contact Termination Finish	Nickel Overall
EVO 1 16 Gpbs	RVPX-PE16DM1	50 μ-Inch min.	Tin	50 μ-Inch Min.
	RVPX-PE16DM2		Tin-lead	
	RVPX-PE16DC1	30 μ-Inch min.	Tin	
	RVPX-PE16DC2		Tin-lead	
EVO 2 32 Gpbs	RVPX-PE216DM1	50 μ-Inches min.	Tin	50 μ-Inches min.
	RVPX-PE216DM2		Tin-Lead	
	RVPX-PE216DC1	30 μ-Inches min	Tin	
	RVPX-PE216DC2		Tin-Lead	

BACKPLANE EVOLUTION 2: 16 Position Middle Backplane

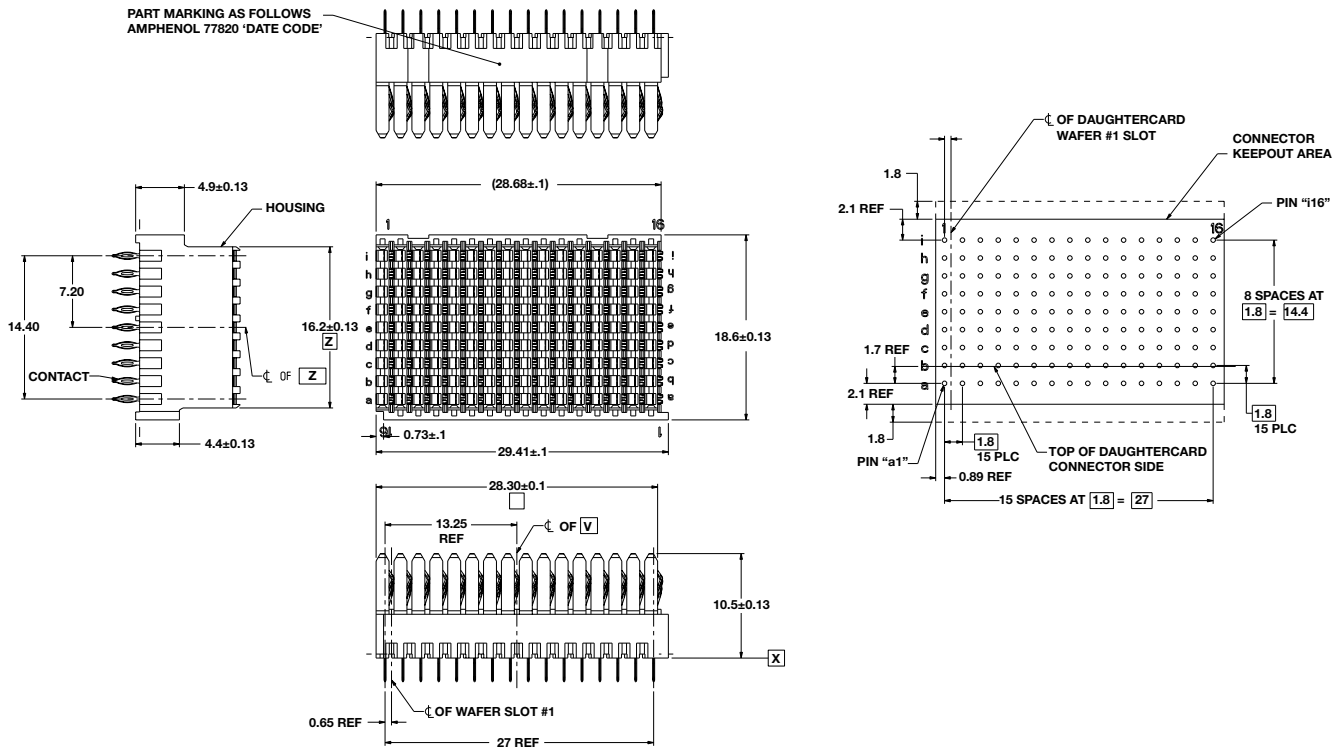

PLATING THICKNESS AND MATERIAL BY PART NUMBER			
Part Number	Gold In Contact Area	Compliant Contact Termination Finish	Nickel Overall
RVPX-JE216MM1	50 μ-Inch min.	Tin	50 μ-Inch Min.
RVPX-JE216MM2		Tin-lead	
RVPX-JE216MC1	30 μ-Inch min.	Tin	
RVPX-JE216MC2		Tin-lead	