

TWO-CHANNEL FIBER TO COPPER MEDIA CONVERTER UNIT

PDS - 343



DESCRIPTION

Amphenol's Two-Channel Fiber to Copper Media Converter unit is able to transfer and convert data at rates up to 4.25Gbps. These converters output to a MIL-DTL-38999 connector embedded with high performance Amphenol contacts and can be configured with any plating and shell rotation. These features are a perfect fit for any application being used in harsh environment avionics, ground systems, or naval applications.

FEATURES & BENEFITS

- Support for agnostic encoded data and pathological data protocols
- 2X fiber optic M29504 receivers at up to 4.25Gbps converted to 2X high speed copper differential AC coupled streams on high speed differential twinax contacts
- 850nm multimode technology and support for 50/125 fiber optic cable (support also for 62.2/125)
- MIL-STD-704 OC input power
- Sea level to 61K feet altitude
- Operation from -55°C to 85°C
- Less than 0.75 pounds
- Wide vibration range suitable for airborne rugged environment
- Qualified for balance of MIL-STD tests to include humidity, shock, explosive atmosphere, EMI, and more.

CF-020011-36X

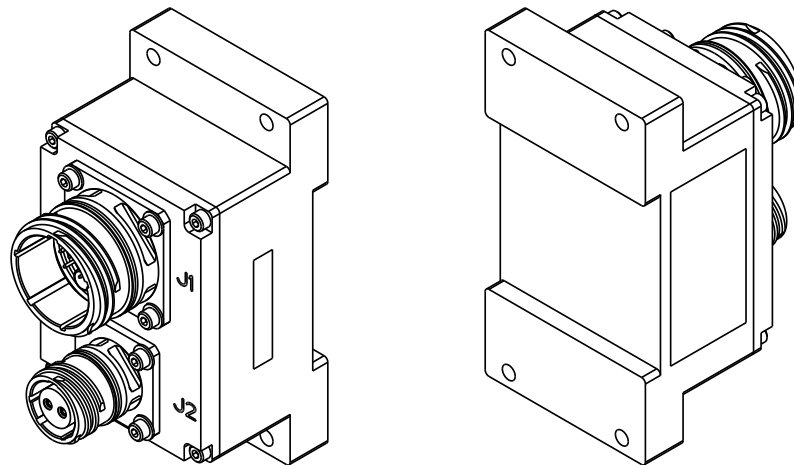
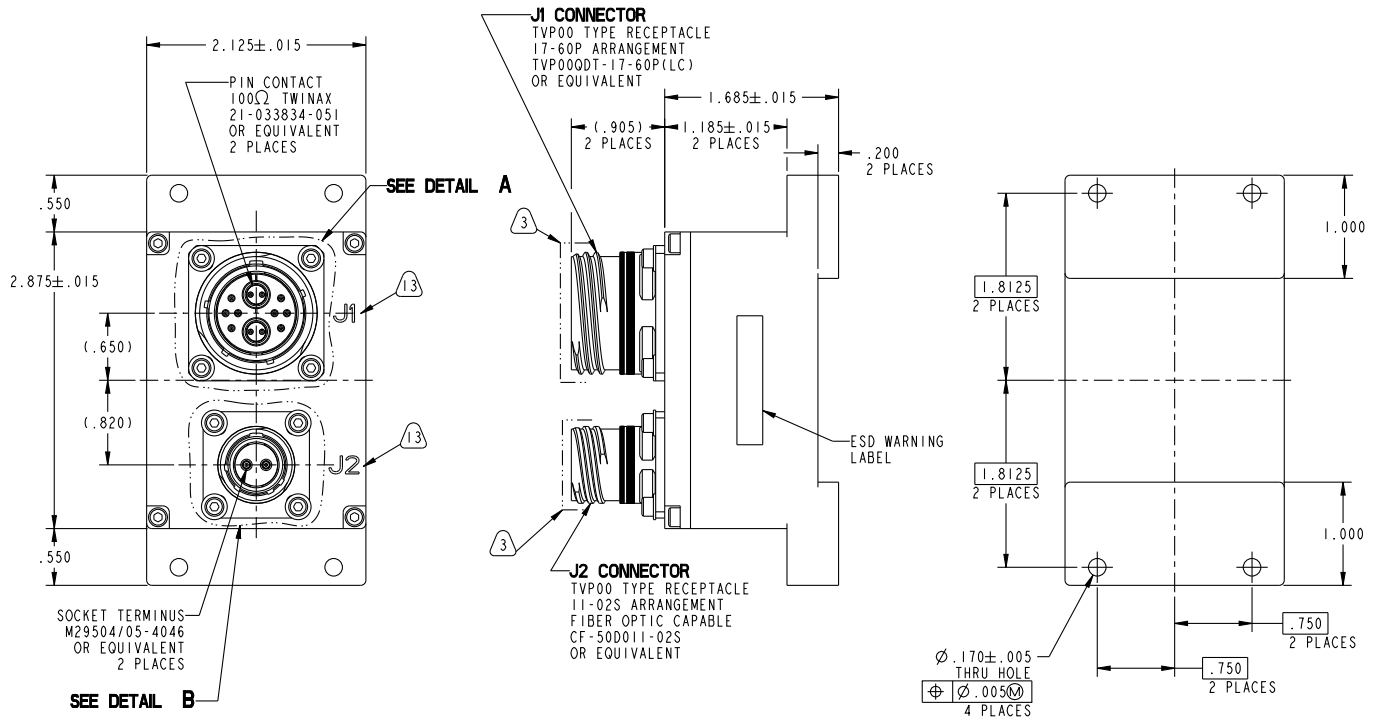

PIN-OUT CHARTS

J2 CONNECTOR I/O CHART	
PIN ID	DESCRIPTION
1-1	COPPER 1 TX+
1-2	COPPER 1 TX-
2	SPARE/DEBUG
3	GND
4	GND
5-1	COPPER 2 TX+
5-2	COPPER 2 TX-
6	SPARE/DEBUG
7	POWER
8	POWER
9	SPARE/DEBUG
10	SPARE/DEBUG

J1 CONNECTOR I/O CHART	
PIN ID	DESCRIPTION
A	FO_RX1
B	FO_RX2