

Amphenol VITA Compliant Connectors

MILITARY AND AEROSPACE APPLICATIONS

Open **VPX CONNECTORS**

VITA 46 • VITA 66.1 • VITA 66.4

VITA 66.5 • VITA 67

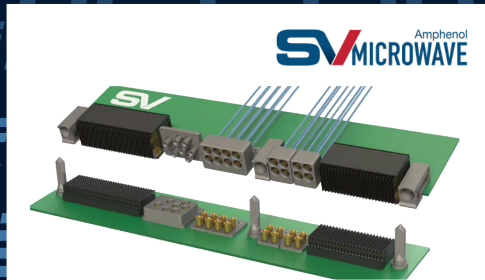

Table of Contents:

Table of Contents:	1	FIBER OPTIC VITA 66.1:	
		Standard 2MT Backplane/Module	42
		Standard 2MT Installation & Assembly	43
		Double Density 4MT Module	44
		Double Density 4MT Backplane	45
		2MT Special Module	46
		2MT Spring Loaded Backplane	47
		FIBER OPTIC VITA 66.4:	
		Standard 1MT Module	48
		Standard 1MT Backplane	49
		1MT Special Module	50
		Spring Loaded 1MT Backplane	51
		Double Density 2MT Module	52
		Double Density 2MT Backplane	53
		Double Density 2MT Special Module	54
		Double Density Spring Loaded 2MT Backplane	55
		LIGHTCONEX VITA 66.5	56-57
		10-743008-00X Module Connector	58
		10-743007-002 Backplane Connector	59
		HIGH DENSITY VITA 67 FOR EMBEDDED COMPUTING	60
		Overview	61
		SMPM VITA 67.1 Plug-in / Backplane Module	62
		SMPM VITA 67.2 Plug-in / Backplane Module	63
		SMPM Female VITA 67.1/2 Plug-in Contact, .047 & .086 cable	64
		SMPM Female VITA 67.1/67.2 to SMA Male Cable	65
		SMPM VITA 67.3C 10-Port Plug-in / Backplane Module	66
		SMPM VITA 67.3 SOSA 14 Port Plug-in / Backplane Module	67
		SMPM Male to SMPM VITA 67.3 MALE Plug-in Adapter	68
		SMPM Female to Female Bullet	68
		SMPM Male Edge Launch Connector, SB	68
		SMPM Female VITA 67.3 Backplane Contact for Cable	69
		SMPM VITA 67.3 Backplane Contact for Cable	70
		SMPS VITA 67.3 12 Port Plug-in Module D & C	71
		SMPS VITA 67.3 12 / 19 Port Backplane Module D	72
		TOOLS:	
		VITA 67 contact removal	73
		VITA 67 cable installation	74
		CONTACT INFORMATION	75
R-VPX RUGGEDIZED VITA 46 - EVO 1 AND EVO 2			
R-VPX Overview:	2-5		
R-VPX Part Number List:	6-7		
DAUGHTER CARD: How to Order	8		
BACKPLANE: How to Order	9		
DAUGHTER CARD: 8 Position Half Left End Module	10		
DAUGHTER CARD: 16 Position Center Differential Module	11		
DAUGHTER CARD: 16 Position Center Single End	11		
BACKPLANE: 8 Position Left End Backplane	12		
BACKPLANE: 16 Position Middle Backplane	13		
BACKPLANE: 16 Position Right End Backplane	14		
R-VPX EVOLUTION SERIES - EVO 1 AND EVO 2	15		
EVO 2 SI Electrical performance	16-17		
EVO 1 and 2 part numbers	18-19		
DAUGHTER CARD: Right-Angle Plug Assembly, 8 Center	20		
BACKPLANE EVOLUTION 2: 8 Position Backplane	21		
DAUGHTER CARD: Right-Angle Plug Assembly, 16 Center	22		
BACKPLANE EVOLUTION 2: 16 Position Middle Backplane	23		
R-VPX REAR TRANSITION MODULE:			
Part Number List	24-25		
Right Angle Plug, Left End, Daughtercard Differential	26		
Right Angle Plug, Center, Daughtercard Differential	27		
Right Angle Plug, Center, Daughtercard	28		
Right Angle Plug, Center, Daughtercard Differential	29		
Right Angle Plug, Center, Daughtercard Differential-SE	30		
Rear Transition Module Center	31		
Rear Transition Module Vertical, Center, Partial Load	32-33		
HARDWARE:			
Zinc Die Cast Guide Modules	34		
Machined Aluminum Guide Modules	35		
Zinc Die Cast Guide Pins	36		
Machined Stainless Steel Guide Pins	37		
Backplane Connector Removal Tools	38		
INSTALLATION	39		
OPTICAL FIBER RUGGEDIZED VITA 66.1 AND 66.4	40		
OPTICAL FIBER VITA OVERVIEW	41		

OVERVIEW:

Amphenol offers a wide range of products designed for OpenVPX™, open architecture system needs.



OpenVPX is the next-generation interoperability standard for system-level defense and aerospace applications. It is ideal for rugged applications that require smaller packages, as well as high I/O densities and higher speed.

OpenVPX leverages the work of the individual VPX standards to reduce customization, testing, cost and risk. It defines an architecture that manages and constrains module and backplane designs, defines pin outs, and sets interoperability compliance while maintaining full compliance with VPX.

All products are compliant to VITA specs and can be designed for interoperability while meeting performance requirements.

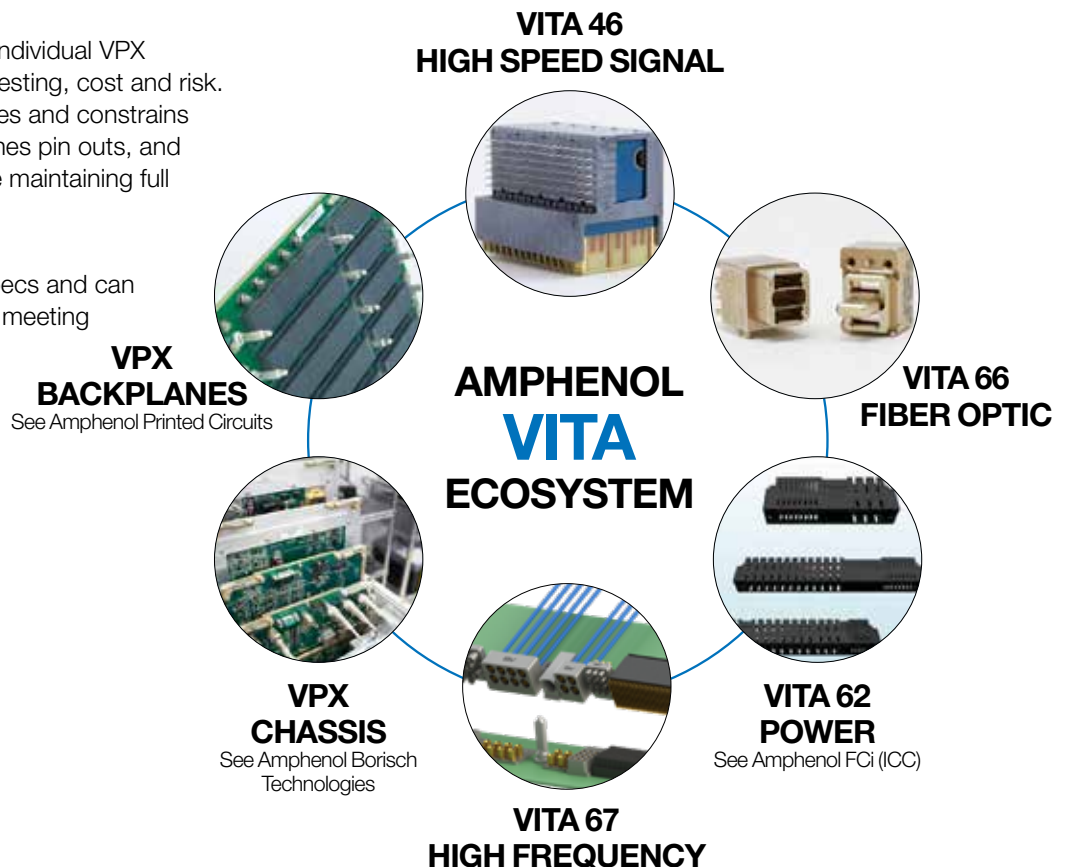

R-VPX Ruggedized VITA 46



Amphenol's R-VPX is a ruggedized, high-speed, board-to-board interconnect system capable of data rates in excess of 10 Gbps, meeting and exceeding VITA 46 standards. This connector system gives users modularity and flexibility by utilizing PCB wafer construction with customized wafer-loading patterns.

R-VPX Ruggedized VITA 46 Connectors are designed for embedded computing applications in:



Commercial and Military Aerospace



Electronic Systems - C4ISR



Missile Defense



Ground Systems



Space Systems



Other Ruggedized Environments

R-VPX Overview:

FEATURES & BENEFITS:

- Qualified to VITA 46 for OpenVPX applications
- Fully intermountable & intermateable to existing VITA 46 connectors
- Meets and exceeds VITA 47
- Ruggedized 4 point contact system
- Modular COTS lightweight connector system
- Low mating force connector system
- Pin-Less backplane connector family
- Supports .8 inch card slot pitches
- Up to 140 signals per inch
- Contact current rating 1.5 Amps
- Can be combined with high power modules, RF
- Modules (VITA 67) and Optical modules (VITA 66)
- -55° to 125°C
- Storage Temperature can be similar to the operating temperature, but it is recommended to store in typical ambient warehouse temperatures.

SUPPORTED HIGH-SPEED PROTOCOLS:

- 1000BASE-KX
- 10GBASE-KX4
- 10GBASE-KR10
- 40GBASE-KR4
- InfiniBand SDR, DDR, and QDR
- PCIe Gen 1, 2, 3, 4 and 5
- Serial RapidIO 2.5, 3.125, 5, 6.25, 12.5 and 25 Gbaud

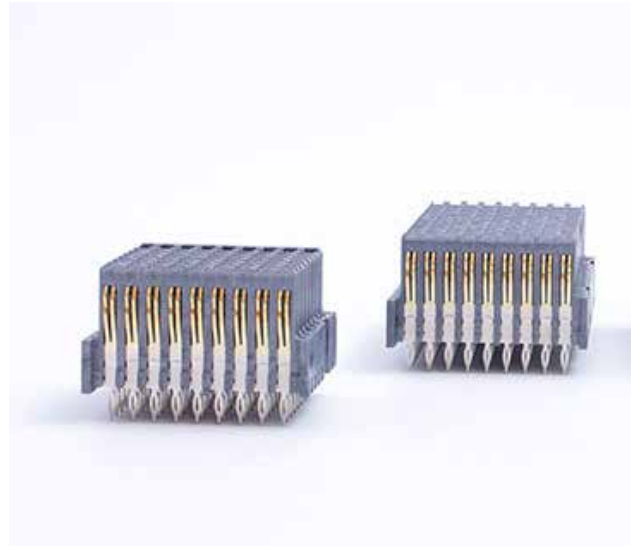

R-VPX Overview:

R-VPX

Signal Integrity Comparison: Insert and Return Loss

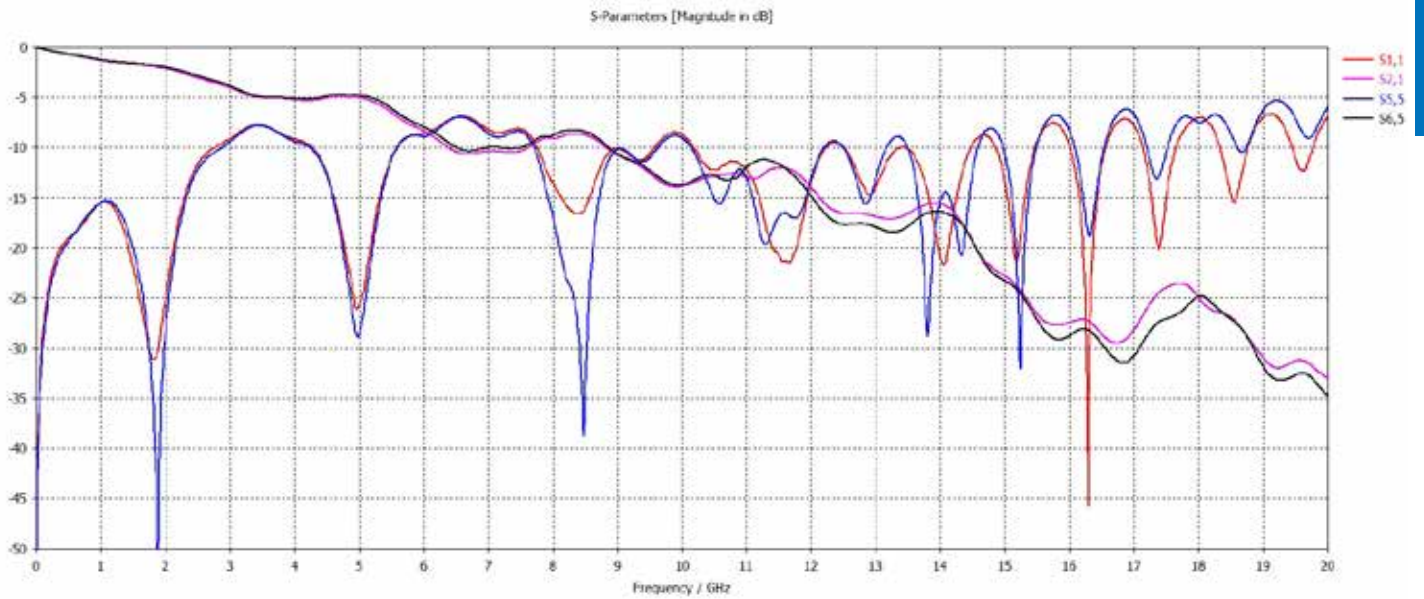

Signal Integrity Comparison: Impedance

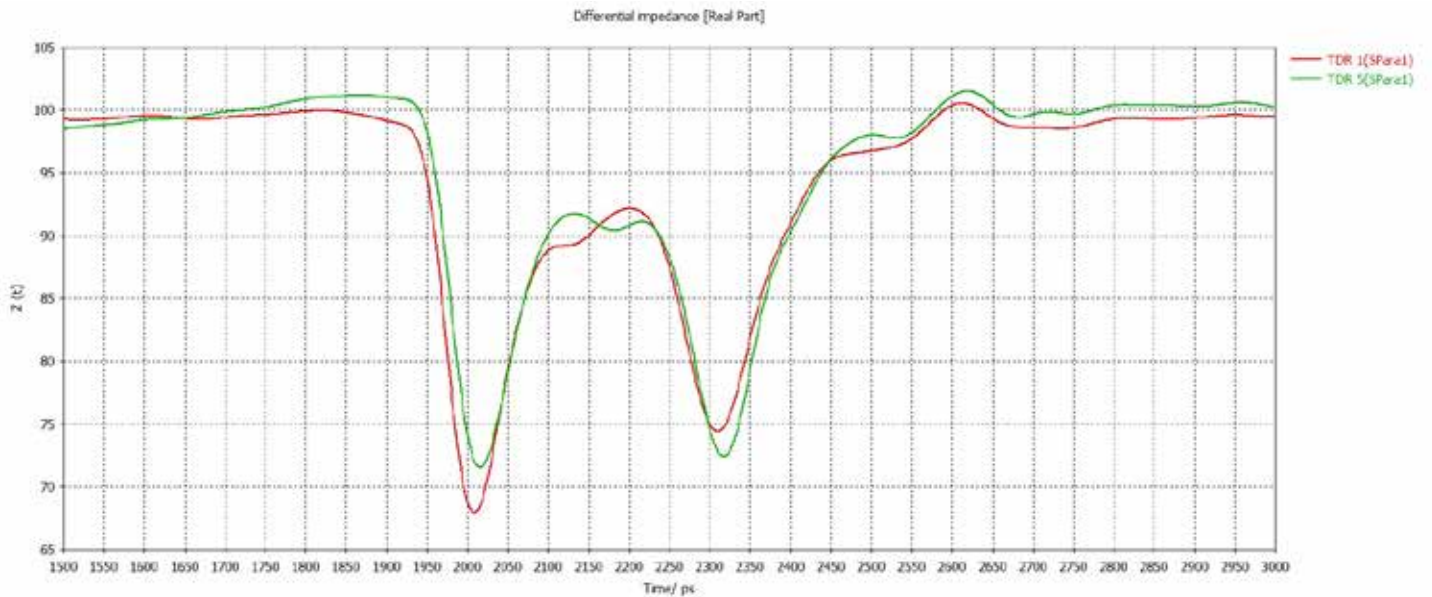

Note \approx 44 ps 10-90% TDR Rise time

R-VPX Part Number List:

Part Number	Gender	Size	Insert Type	Plating	Contact Finish
RVPX-PE16DM1	Evolution Module 1	16	P1-P6 Differential 25Gb/s	50 Micro-Inches	Tin
RVPX-PE216DM1	Evolution 2 Module	16	P1-P6 Differential 32Gb/s	50 Micro-Inches	Tin
RVPX-JE216MM1	Evolution 2 Backplane	16	J1, J3-J5 Middle	50 Micro-Inches	Tin
RVPX-PE16DM2	Evolution Module 1	16	P1-P6 Differential 25Gb/s	50 Micro-Inches	Tin-Lead
RVPX-PE216DM2	Evolution 2 Module	16	P1-P6 Differential 32Gb/s	50 Micro-Inches	Tin-Lead
RVPX-JE216MM2	Evolution 2 Backplane	16	J1, J3-J5 Middle	50 Micro-Inches	Tin-Lead
RVPX-PE16DC1	Evolution Module 1	16	P1-P6 Differential 25Gb/s	30 Micro-Inches	Tin
RVPX-PE216DC1	Evolution 2 Module	16	P1-P6 Differential 32Gb/s	30 Micro-Inches	Tin
RVPX-JE216MC1	Evolution 2 Backplane	16	J1, J3-J5 Middle	30 Micro-Inches	Tin
RVPX-PE16DC2	Evolution Module 1	16	P1-P6 Differential 25Gb/s	30 Micro-Inches	Tin-Lead
RVPX-PE216DC2	Evolution 2 Module	16	P1-P6 Differential 32Gb/s	30 Micro-Inches	Tin-Lead
RVPX-JE216MC2	Evolution 2 Backplane	16	J1, J3-J5 Middle	30 Micro-Inches	Tin-Lead

Part Number	Gender	Size	Insert Type	Plating	Contact Finish
RVPX-P08VM1	Std Module	8	P0 V- VITA 46	50 Micro-Inches	Tin
RVPX-P08DM1	Std Module	8	P0 Differential 10Gb/s	50 Micro-Inches	Tin
RVPX-P08SM1	Std Module	8	P0 Single-Ended	50 Micro-Inches	Tin
RVPX-P08PM1	Std Module	8	P0 Power	50 Micro-Inches	Tin
RVPX-P16DM1	Std Module	16	P1-P6 Differential 10Gb/s	50 Micro-Inches	Tin
RVPX-P16SM1	Std Module	16	P1-P6 Single-Ended	50 Micro-Inches	Tin
RVPX-P16PM1	Std Module	16	P1-P6 Power	50 Micro-Inches	Tin
RVPX-P08VM2	Std Module	8	P0 V- VITA 46	50 Micro-Inches	Tin-Lead
RVPX-P08DM2	Std Module	8	P0 Differential 10Gb/s	50 Micro-Inches	Tin-Lead
RVPX-P08SM2	Std Module	8	P0 Single-Ended	50 Micro-Inches	Tin-Lead
RVPX-P08PM2	Std Module	8	P0 Power	50 Micro-Inches	Tin-Lead
RVPX-P16DM2	Std Module	16	P1-P6 Differential 10Gb/s	50 Micro-Inches	Tin-Lead
RVPX-P16SM2	Std Module	16	P1-P6 Single-Ended	50 Micro-Inches	Tin-Lead
RVPX-P16PM2	Std Module	16	P1-P6 Power	50 Micro-Inches	Tin-Lead
RVPX-P08VC1	Std Module	8	P0 V- VITA 46	30 Micro-Inches	Tin
RVPX-P08DC1	Std Module	8	P0 Differential 10Gb/s	30 Micro-Inches	Tin
RVPX-P08SC1	Std Module	8	P0 Single-Ended	30 Micro-Inches	Tin
RVPX-P08PC1	Std Module	8	P0 Power	30 Micro-Inches	Tin

R-VPX Part Number List:

Part Number	Gender	Size	Insert Type	Plating	Contact Finish
RVPX-P16DC1	Std Module	16	P1-P6 Differential 10Gb/s	30 Micro-Inches	Tin
RVPX-P16SC1	Std Module	16	P1-P6 Single-Ended	30 Micro-Inches	Tin
RVPX-P16PC1	Std Module	16	P1-P6 Power	30 Micro-Inches	Tin
RVPX-P08VC2	Std Module	8	P0 V- VITA 46	30 Micro-Inches	Tin-Lead
RVPX-P08DC2	Std Module	8	P0 Differential 10Gb/s	30 Micro-Inches	Tin-Lead
RVPX-P08SC2	Std Module	8	P0 Single-Ended	30 Micro-Inches	Tin-Lead
RVPX-P08PC2	Std Module	8	P0 Power	30 Micro-Inches	Tin-Lead
RVPX-P16DC2	Std Module	16	P1-P6 Differential 10Gb/s	30 Micro-Inches	Tin-Lead
RVPX-P16SC2	Std Module	16	P1-P6 Single-Ended	30 Micro-Inches	Tin-Lead
RVPX-P16PC2	Std Module	16	P1-P6 Power	30 Micro-Inches	Tin-Lead
RVPX-J08EM1	Backplane	8	J0 End	50 Micro-Inches	Tin
RVPX-J08EC1	Backplane	8	J0 End	30 Micro-Inches	Tin
RVPX-J08EM2	Backplane	8	J0 End	50 Micro-Inches	Tin-Lead
RVPX-J08EC2	Backplane	8	J0 End	30 Micro-Inches	Tin-Lead
RVPX-J16MM1	Backplane	16	J1, J3-J5 Middle	50 Micro-Inches	Tin
RVPX-J16MC1	Backplane	16	J1, J3-J5 Middle	30 Micro-Inches	Tin
RVPX-J16EM1	Backplane	16	J2, J6 End	50 Micro-Inches	Tin
RVPX-J16EC1	Backplane	16	J2, J6 End	30 Micro-Inches	Tin
RVPX-J16MM2	Backplane	16	J1, J3-J5 Middle	50 Micro-Inches	Tin-Lead
RVPX-J16MC2	Backplane	16	J1, J3-J5 Middle	30 Micro-Inches	Tin-Lead
RVPX-J16EM2	Backplane	16	J2, J6 End	50 Micro-Inches	Tin-Lead
RVPX-J16EC2	Backplane	16	J2, J6 End	30 Micro-Inches	Tin-Lead

DAUGHTER CARD: How to Order R-VPX and EVO-1

Complete steps 1-6 to create your part number

1.	2.	3.	4.	5.	6.
Connector Type	Gender	Size	Insert Type	Contact Plating	Contact Termination Finish
RVPX-	P	16	D	M	1

STEP 1 :

Connector Type	
RVPX-	Rugged High Speed Board

STEP 2 :

Gender	
P	Module 10 Gb/s
PE	Evolution Module 16 Gb/s
PE2	Evolution Module 2 32 Gb/s

STEP 3 :

Size	Gender P & PE2
08	8 Position Insert
16	16 Position Insert

Size	Gender PE
16	16 Position Insert

STEP 4 :

Insert Type	P08
D	Differential
S	Single-Ended
P	Power
V	Standard VITA 46 P0 Load

Insert Type	P16
D	Differential
S	Single-Ended
P	Power

Insert Type	PE16 & PE216
D	Differential

Insert Type	PE208
V	Standard VITA 46 P0 Load

STEP 5 :

Contact Plating	
M	50 Micro-Inches Gold
C	30 Micro-Inches Gold

STEP 6 :

Contact Termination Finish	
1	Tin 
2	Tin-Lead

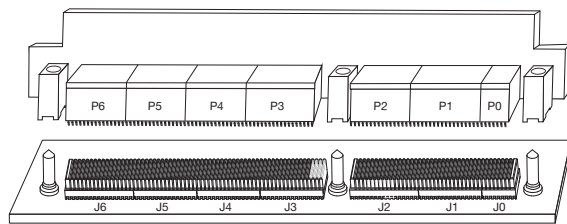

Daughter Card		
Module Position	Part No. Amphenol R-VPX Connectors	
P0	RVPX-P08VCX	RVPX-P08VMX*
P1, P2, P3, P4, P5, P6	Differential	RVPX-P16DCX RVPX-P16DMX*
	Single-Ended	RVPX-P16SCX RVPX-P16SMX*
Keying Guide Modules	RVPX-HMD-X	RVPX-HMM-X

BACKPLANE: How to Order

R-VPX

Complete steps 1-6 to create your part number

1.	2.	3.	4.	5.	6.
Connector Type	Gender	Size	Insert Type	Contact Plating	Contact Termination Finish
RVPX-	J	16	E	M	1

STEP 1 :

Connector Type	
RVPX-	Rugged High Speed Board

STEP 2 :

Gender	
J	Backplane
JE2	Backplane 32 Gbps

STEP 3 :

Size	
08	8 Position Insert
16	16 Position Insert

STEP 4 :

Insert Type	
J08 & JE208	
E	End

Insert Type	
J16 & JE216	
M	Middle
E	End

STEP 5 :

Contact Plating	
M	50 Micro-Inches Gold
C	30 Micro-Inches Gold

STEP 6 :

Contact Termination Finish	
1	Tin
2	Tin-Lead

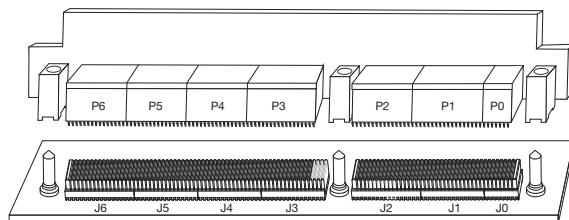

Backplane		
Module Position	Part No. Amphenol R-VPX Connectors	
J0	RVPX-J08ECX	RVPX-J08EMX*
J1, J3, J4, J5	RVPX-J16MCX	RVPX-J16MMX*
J2, J6	RVPX-J16ECX	RVPX-J16EMX*
Keying Guide Modules		
	RVPX-HPD-X	RVPX-HPM-X

DAUGHTER CARD: 8 Position Half Left End Module

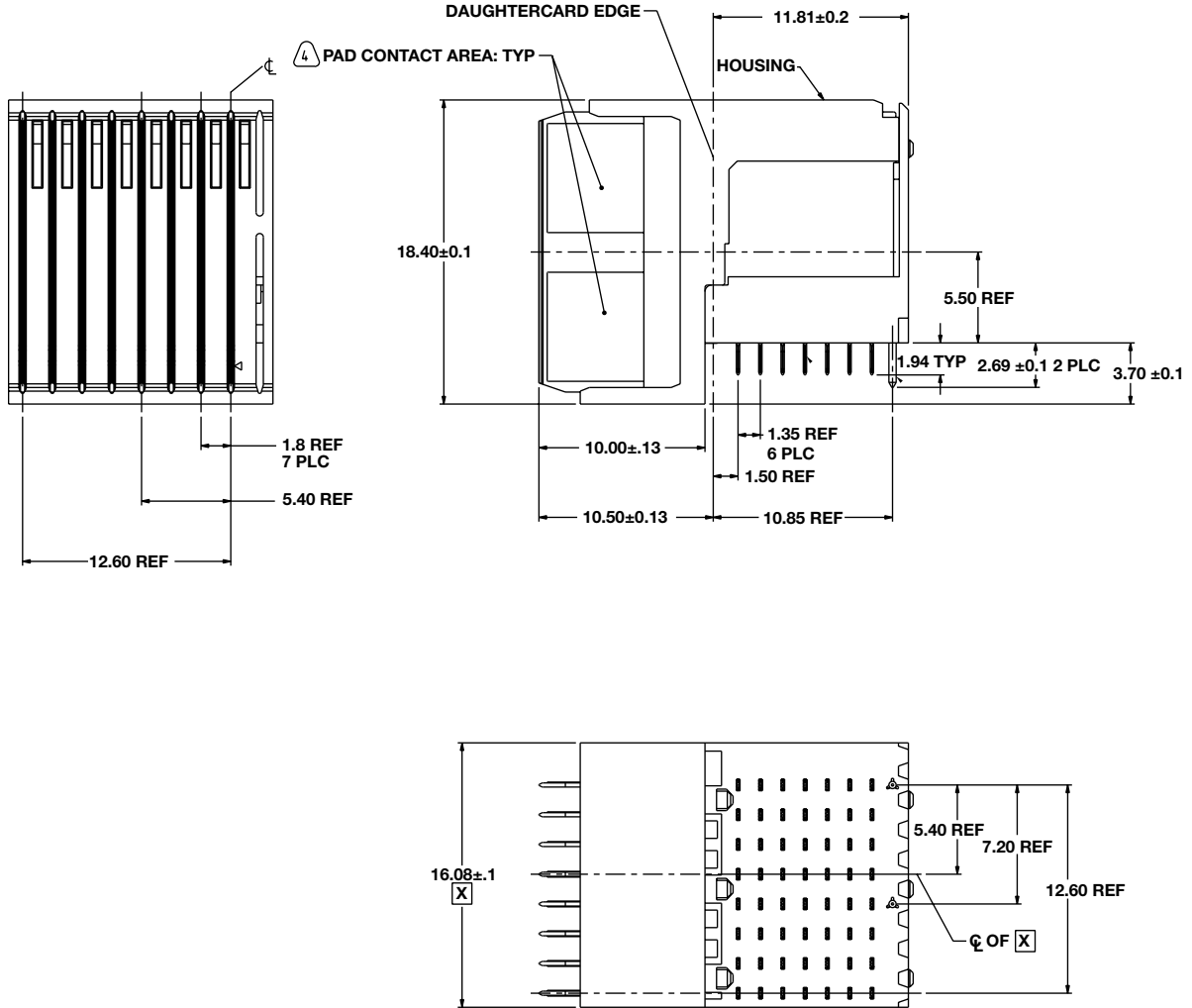

PLATING THICKNESS AND MATERIAL BY PART NUMBER

Part Number	Gold In Contact Area	Compliant Contact Termination Finish	Nickel Overall
RVPX-P08VM1	50 µ-Inch min.	Tin	50 µ-Inch Min.
RVPX-P08VM2		Tin-lead	
RVPX-P08VC1	30 µ-Inch min.	Tin	
RVPX-P08VC2		Tin-lead	

DAUGHTER CARD: 16 Position Center Differential Module

R-VPX

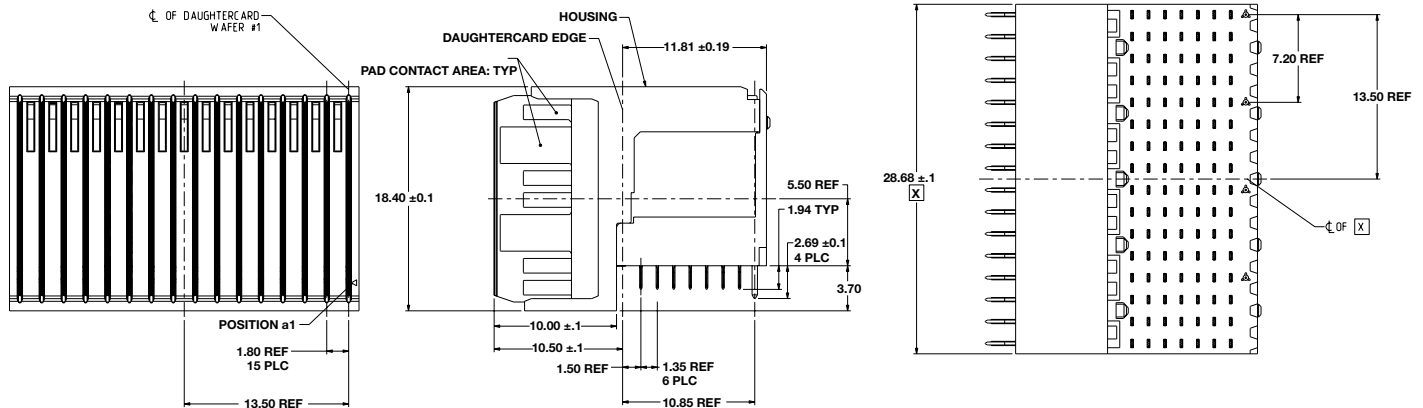

PLATING THICKNESS AND MATERIAL BY PART NUMBER			
Part Number	Gold In Contact Area	Compliant Contact Termination Finish	Nickel Overall
RVPX-P16DM1	50 μ-Inch min.	Tin	50 μ-Inch Min.
RVPX-P16DM2		Tin-lead	
RVPX-P16DC1	30 μ-Inch min.	Tin	
RVPX-P16DC2		Tin-lead	

DAUGHTER CARD: 16 Position Center Single End

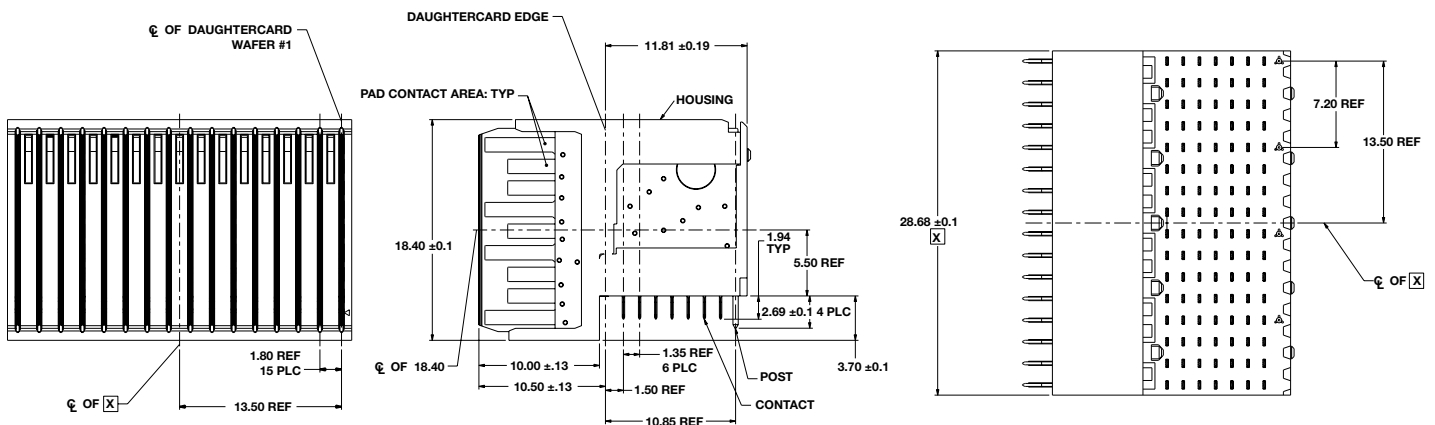

PLATING THICKNESS AND MATERIAL BY PART NUMBER			
Part Number	Gold In Contact Area	Compliant Contact Termination Finish	Nickel Overall
RVPX-P16SM1	50 μ-Inch min.	Tin	50 μ-Inch Min.
RVPX-P16SM2		Tin-lead	
RVPX-P16SC1	30 μ-Inch min.	Tin	
RVPX-P16SC2		Tin-lead	

BACKPLANE: 8 Position Left End Backplane

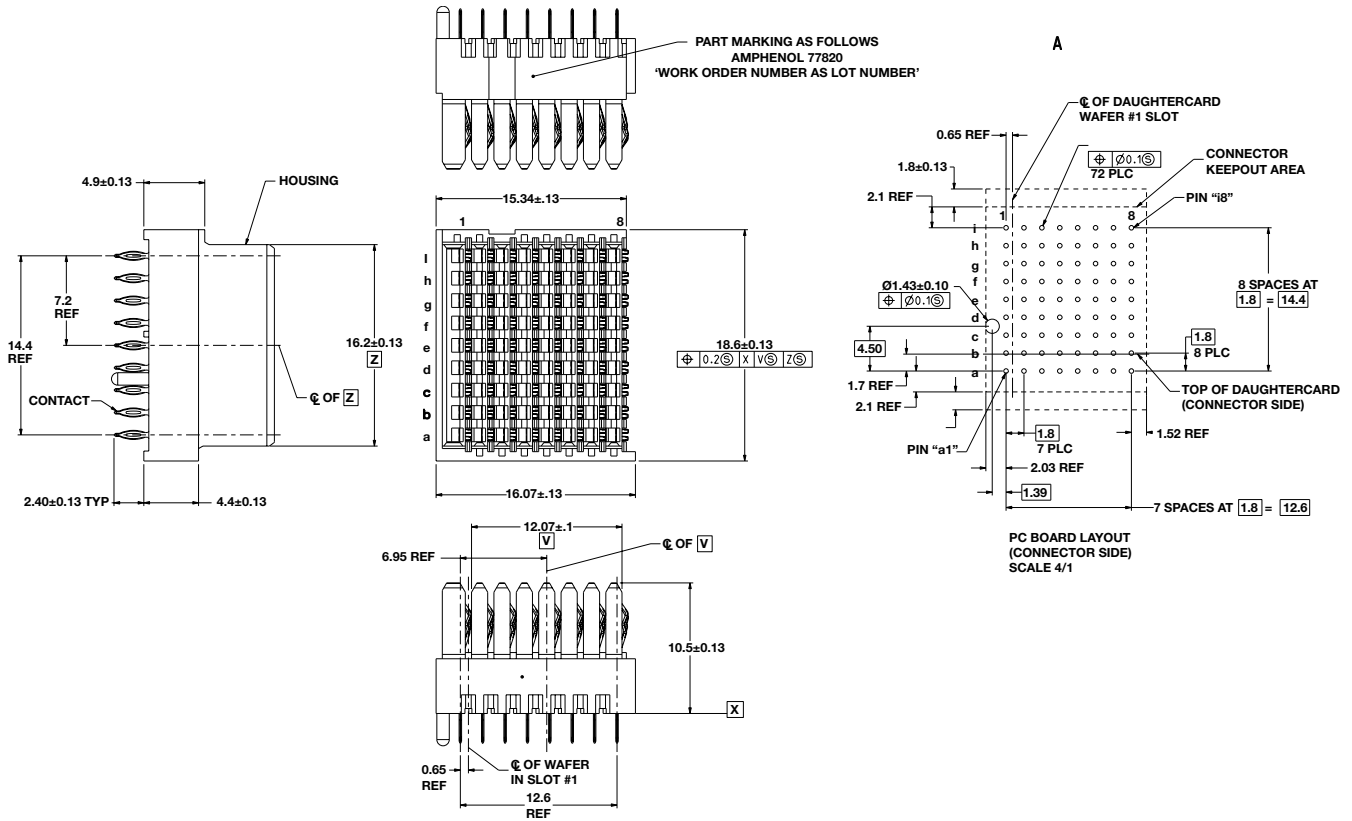

PLATING THICKNESS AND MATERIAL BY PART NUMBER

Part Number	Gold In Contact Area	Compliant Contact Termination Finish	Nickel Overall
RVPX-J08EM1	50 µ-Inch min.	Tin	50 µ-Inch Min.
RVPX-J08EM2		Tin-lead	
RVPX-J08EC1	30 µ-Inch min.	Tin	
RVPX-J08EC2		Tin-lead	

BACKPLANE: 16 Position Middle Backplane

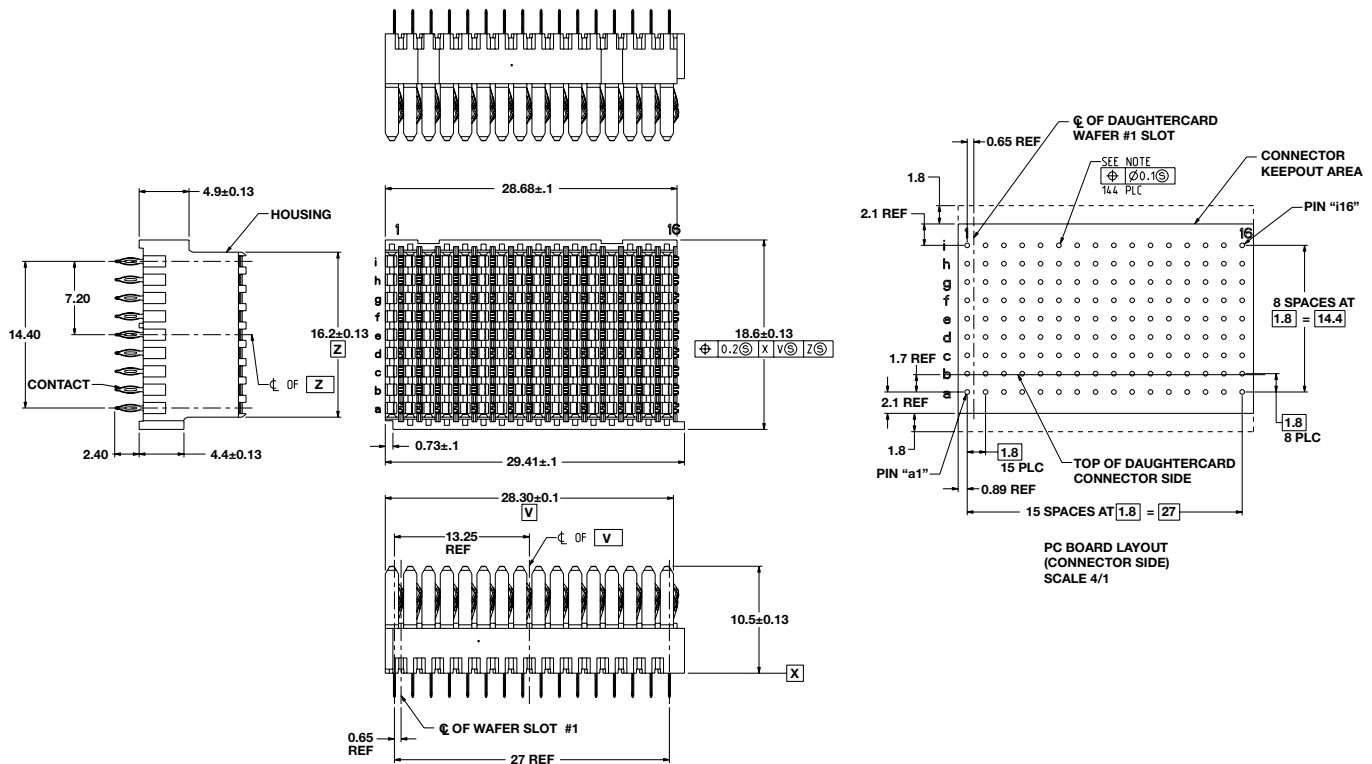

PLATING THICKNESS AND MATERIAL BY PART NUMBER			
Part Number	Gold In Contact Area	Compliant Contact Termination Finish	Nickel Overall
RVPX-J16MM1	50 µ-Inch min.	Tin	50 µ-Inch Min.
RVPX-J16MM2		Tin-lead	
RVPX-J16MC1	30 µ-Inch min.	Tin	
RVPX-J16MC2		Tin-lead	

BACKPLANE: 16 Position Right End Backplane

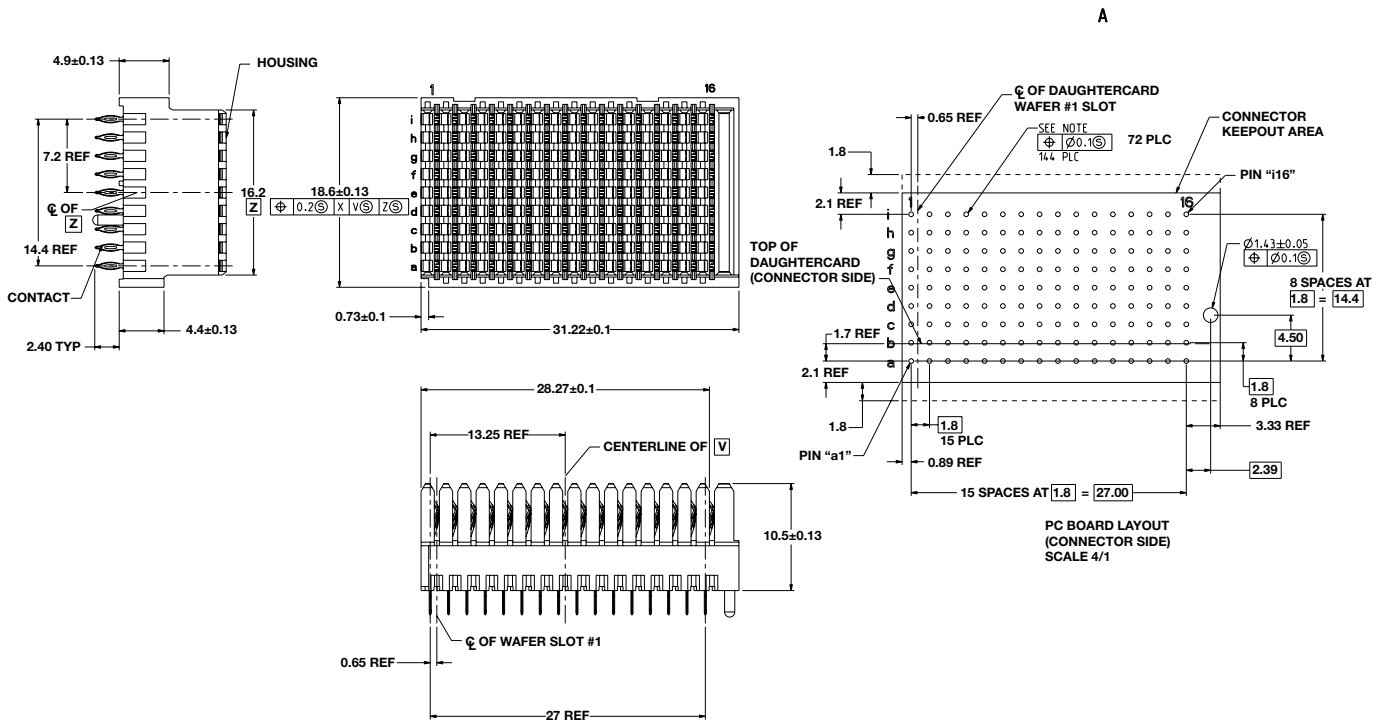

PLATING THICKNESS AND MATERIAL BY PART NUMBER			
Part Number	Gold In Contact Area	Compliant Contact Termination Finish	Nickel Overall
RVPX-J16EM1	50 μ-Inch min.	Tin	50 μ-Inch Min.
RVPX-J16EM2		Tin-lead	
RVPX-J16EC1	30 μ-Inch min.	Tin	
RVPX-J16EC2		Tin-lead	

R-VPX EVOLUTION SERIES HIGH SPEED EVOLUTION



R-VPX EVO

Amphenol introduces R-VPX Evolution Module up to 32 Gbps data rate transfer performance.

R-VPX EVOLUTION 1.0:

- 16 Gb/s+ Performance
- 4 Point Contact System
- Module connector has modified footprint- utilizes smaller compliant contacts for increased Si performance.
- Backplane connector is the legacy connector- no changes necessary on the backplane.
- Intermateable with existing/legacy VITA 46 connectors
- Footprint compliant with 46.30 (VITA Draft Spec)

R-VPX EVOLUTION 2.0:

- 32Gb/s Performance
- 4 Point Contact System
- Module AND Backplane connectors utilize smaller compliant contacts for increase Si performance
- Intermateable with existing/legacy VITA 46 connectors.
- 46.30 Spec compliant

FEATURES AND BENEFITS

Supports High Speed Protocols

- PCIe Gen 4 and Gen 5
- 1000BASE-KX
- 10GBASE-KX4
- 100GBASE-KR4
- Infiniband SDR, DDR, and QDR
- Serial RapidIO 12.5 Gbaud and 25 Gbaud

EVO 2 SI ELECTRICAL PERFORMANCE

Mated Configuration

R-VPX EVO

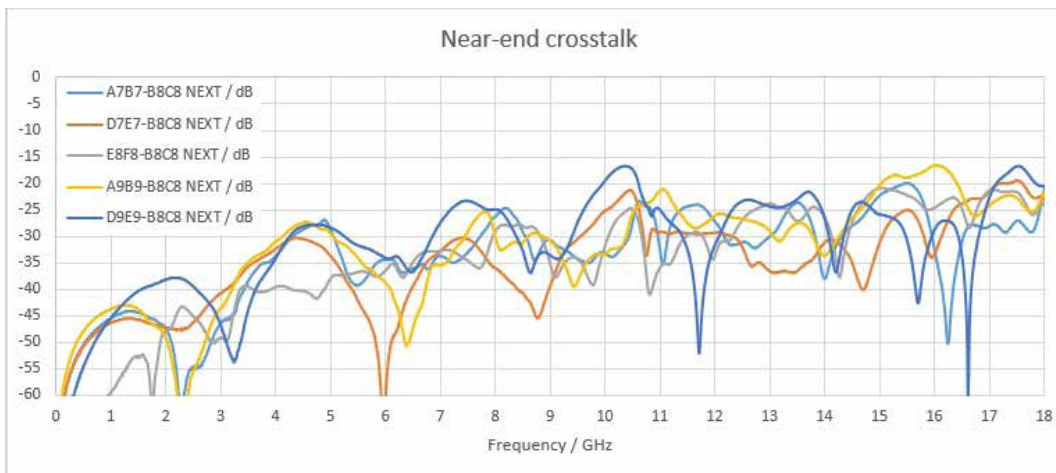

EVO 2 SI ELECTRICAL PERFORMANCE

Eye pattern @ 25.8 Gbps

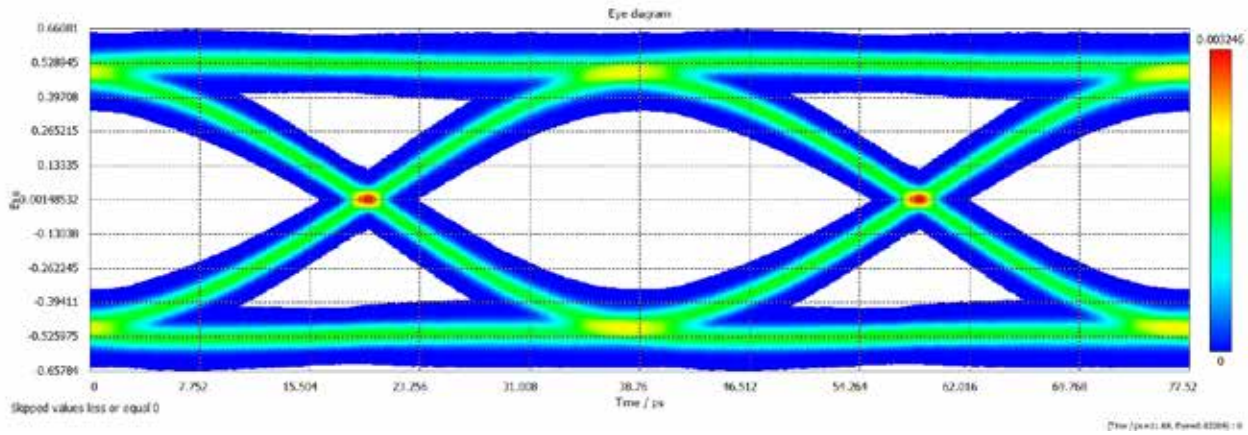

R-VPX EVO

Note: PRBS-23 signal through D7E7-E7F7 pair with all surrounding pairs as active aggressors

Eye pattern @ 32 Gbps

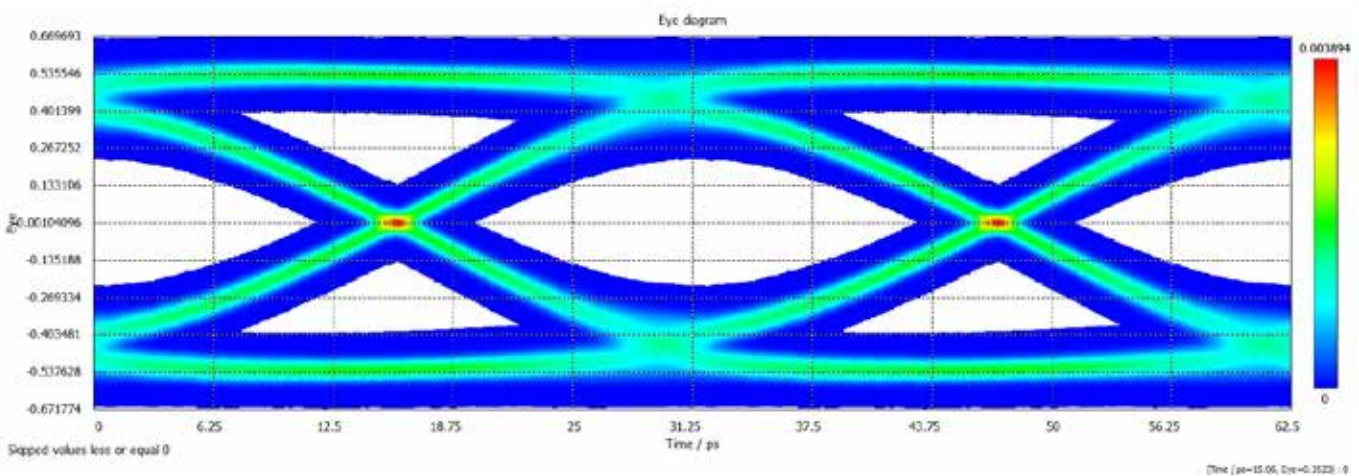

Note: PRBS-23 signal through D7E7-E7F7 pair with all surrounding pairs as active aggressors

R-VPX EVOLUTION SERIES - EVO 1 AND 2 PART NUMBERS

R-VPX EVO

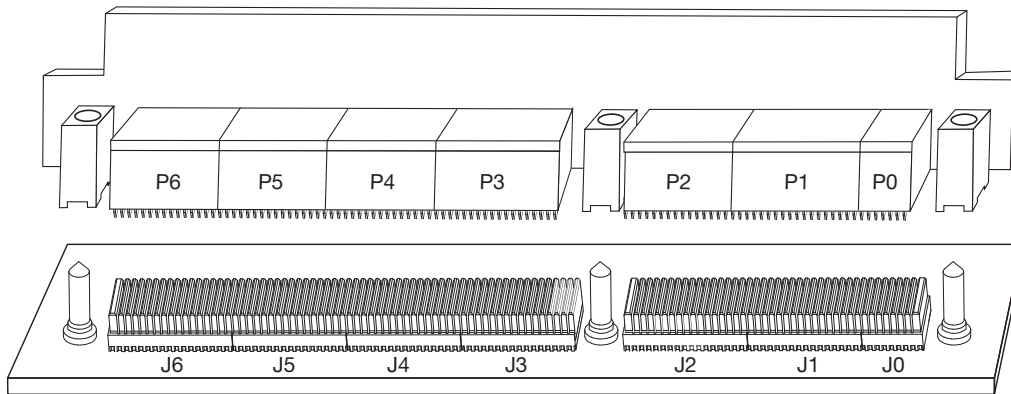

	Part Number	Location	Gold in Contact Area	Compliant Contact Termination Finish	Nickel Overall
EVO 2 8 Pos Module	RVPX-PE208VM1	P0	50 u-inch min.	Tin	50 u-Inch min.
	RVPX-PE208VM2	P0		Tin-Lead	
	RVPX-PE208VC1	P0	30 u-inch min.	Tin	50 u-Inch min.
	RVPX-PE208VC2	P0		Tin-Lead	
EVO 1 16 Pos Module	RVPX-PE16DM1	P1-P6	50 u-inch min.	Tin	50 u-Inch min.
	RVPX-PE16DM2	P1-P6		Tin-Lead	
	RVPX-PE16DC1	P1-P6	30 u-inch min.	Tin	50 u-Inch min.
	RVPX-PE16DC2	P1-P6		Tin-Lead	
EVO 2 16 Pos Module	RVPX-PE216DM1	P1-P6	50 u-inch min.	Tin	50 u-Inch min.
	RVPX-PE216DM2	P1-P6		Tin-Lead	
	RVPX-PE216DC1	P1-P6	30 u-inch min.	Tin	50 u-Inch min.
	RVPX-PE216DC2	P1-P6		Tin-Lead	
EVO 2 8 Pos Backplane	RVPX-JE208EM1	J0	50 u-inch min.	Tin	50 u-Inch min.
	RVPX-JE208EM2	J0		Tin-Lead	
	RVPX-JE208EC1	J0	30 u-inch min.	Tin	50 u-Inch min.
	RVPX-JE208EC2	J0		Tin-Lead	
EVO 2 16 Pos Backplane	RVPX-JE216MM1	J1, J3-J5	50 u-inch min.	Tin	50 u-Inch min.
	RVPX-JE216MM2	J1, J3-J5		Tin-Lead	
	RVPX-JE216MC1	J1, J3-J5	30 u-inch min.	Tin	50 u-Inch min.
	RVPX-JE216MC2	J1, J3-J5		Tin-Lead	
	RVPX-JE216EM1	J2, J6	50 u-inch min.	Tin	50 u-Inch min.
	RVPX-JE216EM2	J2, J6		Tin-Lead	
	RVPX-JE216EC1	J2, J6	30 u-inch min.	Tin	50 u-Inch min.
	RVPX-JE216EC2	J2, J6		Tin-Lead	

R-VPX EVOLUTION SERIES - EVO 2 PART NUMBERS

Hybrid Configurations

Evo 2 Hybrid Configurations					
Part Number	Gender	Rows of Contacts	Insert Type	Plating	Contact Finish
RVPX-PE20817M2	EVO 2 Module	8	P0 V - VITA 46 Hybrid	50 Micro-Inches	Tin-Lead
RVPX-PE21609M2	EVO 2 Module	16	Hybrid PO+P1A	50 Micro-Inches	Tin-Lead
RVPX-PE20817M1	EVO 2 Module	8	P0 V - VITA 46 Hybrid	50 Micro-Inches	Tin
RVPX-PE21609M1	EVO 2 Module	16	Hybrid PO+P1A	50 Micro-Inches	Tin
RVPX-PE20817C2	EVO 2 Module	8	P0 V - VITA 46 Hybrid	30 Micro-Inches	Tin-Lead
RVPX-PE21609C2	EVO 2 Module	16	Hybrid PO+P1A	30 Micro-Inches	Tin-Lead
RVPX-PE20817C1	EVO 2 Module	8	P0 V - VITA 46 Hybrid	30 Micro-Inches	Tin
RVPX-PE21609C1	EVO 2 Module	16	Hybrid PO+P1A	30 Micro-Inches	Tin
RVPX-JE20818M2	EVO 2 Backplane	8	J0 End Hybrid	50 Micro-Inches	Tin-Lead
RVPX-JE21616M2	EVO 2 Backplane	16	Hybrid J0+J1A	50 Micro-Inches	Tin-Lead
RVPX-JE20818M1	EVO 2 Backplane	8	J0 End Hybrid	50 Micro-Inches	Tin
RVPX-JE21616M1	EVO 2 Backplane	16	Hybrid J0+J1A	50 Micro-Inches	Tin
RVPX-JE20818C2	EVO 2 Backplane	8	J0 End Hybrid	30 Micro-Inches	Tin-Lead
RVPX-JE21616C2	EVO 2 Backplane	16	Hybrid J0+J1A	30 Micro-Inches	Tin-Lead
RVPX-JE20818C1	EVO 2 Backplane	8	J0 End Hybrid	30 Micro-Inches	Tin
RVPX-JE21616C1	EVO 2 Backplane	16	Hybrid J0+J1A	30 Micro-Inches	Tin

R-VPX EVO

R-VPX EVOLUTION SERIES- EVO 2

DAUGHTER CARD: Right-Angle Plug Assembly, 8 Center

R-VPX EVO

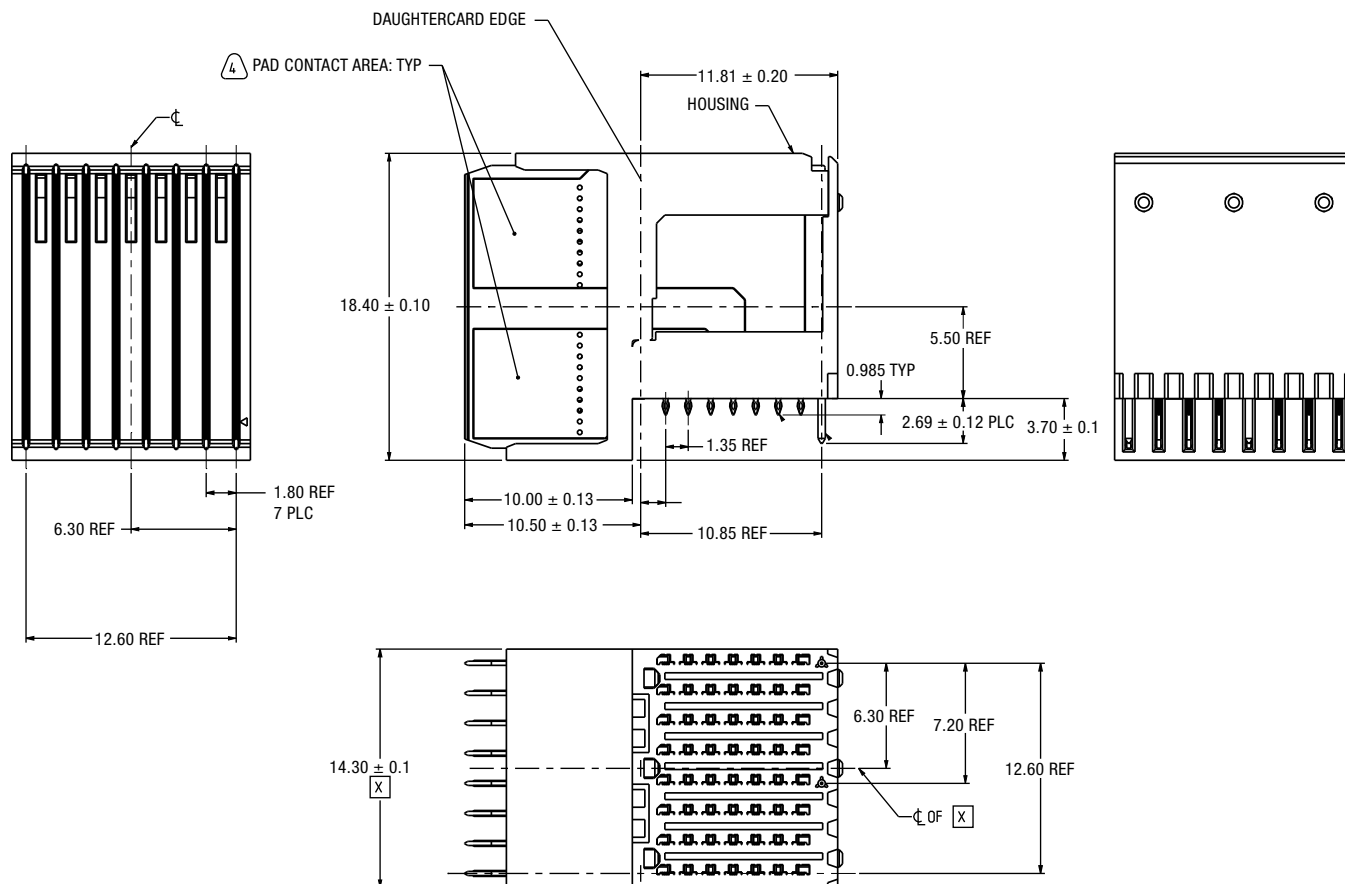

PLATING THICKNESS AND MATERIAL BY PART NUMBER			
Part Number	Gold in Contact Area	Compliant	Nickel Overview
RVPX-PE208VM1	1 50 μ-INCH MIN	50 μ-INCH MIN TIN	50 μ-INCH MIN
RVPX-PE208VM2	50 μ-INCH MIN	50 μ-INCH MIN TIN	50 μ-INCH MIN
RVPX-PE208VC1	30 μ-INCH MIN	50 μ-INCH MIN TIN	50 μ-INCH MIN
RVPX-PE208VC2	30 μ-INCH MIN	50 μ-INCH MIN TIN	50 μ-INCH MIN

BACKPLANE EVOLUTION 2: 8 Position Backplane

R-VPX EVO

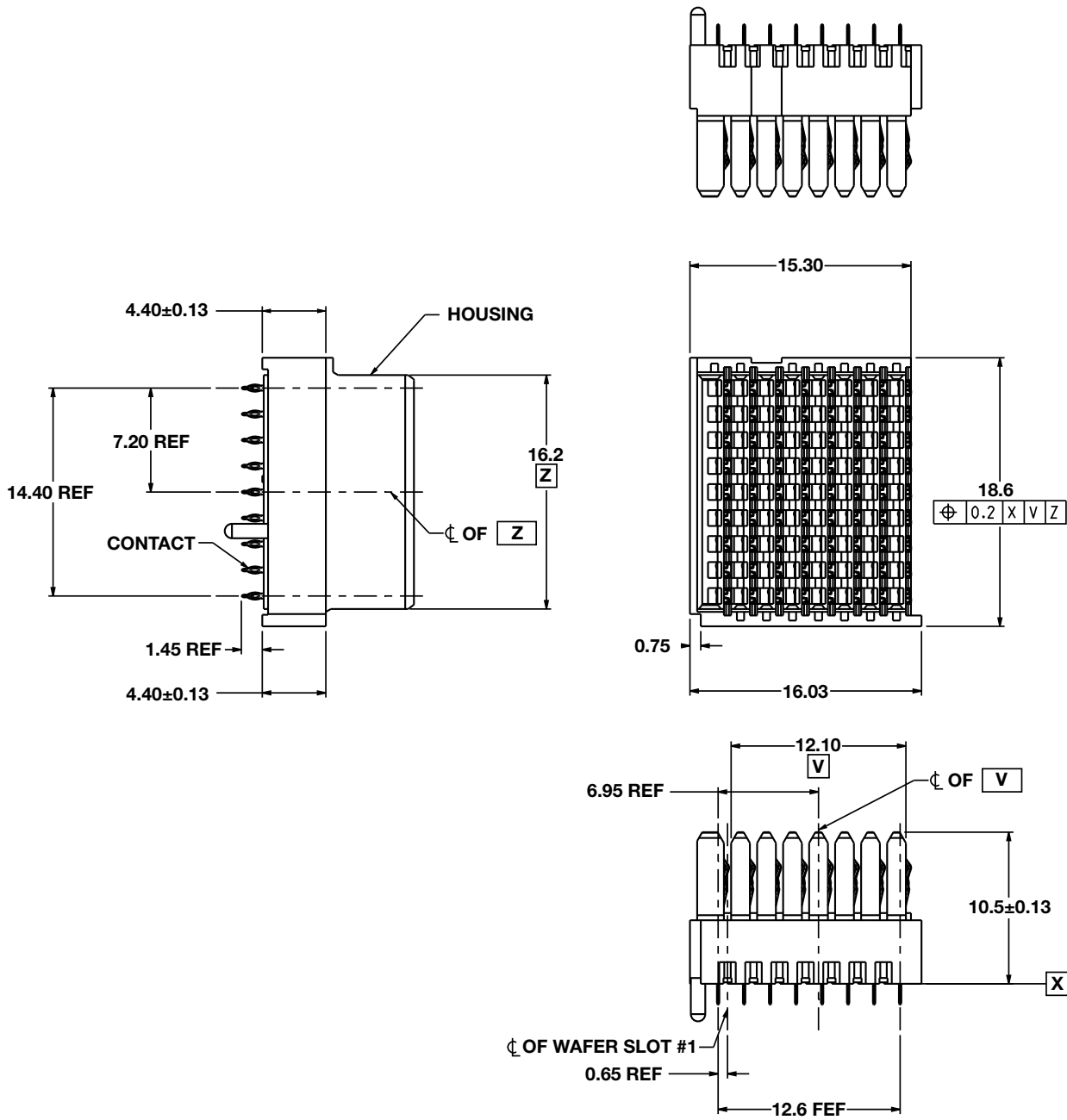

PLATING THICKNESS AND MATERIAL BY PART NUMBER

Part Number	Gold in Contact Area	Compliant	Nickel Overview
RVPX-JE208EM1	50 μ-INCH MIN	50 μ-INCH MIN TIN	50 μ-INCH MIN
RVPX-JE208EM2	50 μ-INCH MIN	50 μ-INCH MIN TIN-LEAD	50 μ-INCH MIN
RVPX-JE208EC1	30 μ-INCH MIN	50 μ-INCH MIN TIN	50 μ-INCH MIN
RVPX-JE208EC2	30 μ-INCH MIN	50 μ-INCH MIN TIN-LEAD	50 μ-INCH MIN

R-VPX EVOLUTION SERIES- EVO 1 & EVO 2

DAUGHTER CARD: Right-Angle Plug Assembly, 16 Center

R-VPX EVO

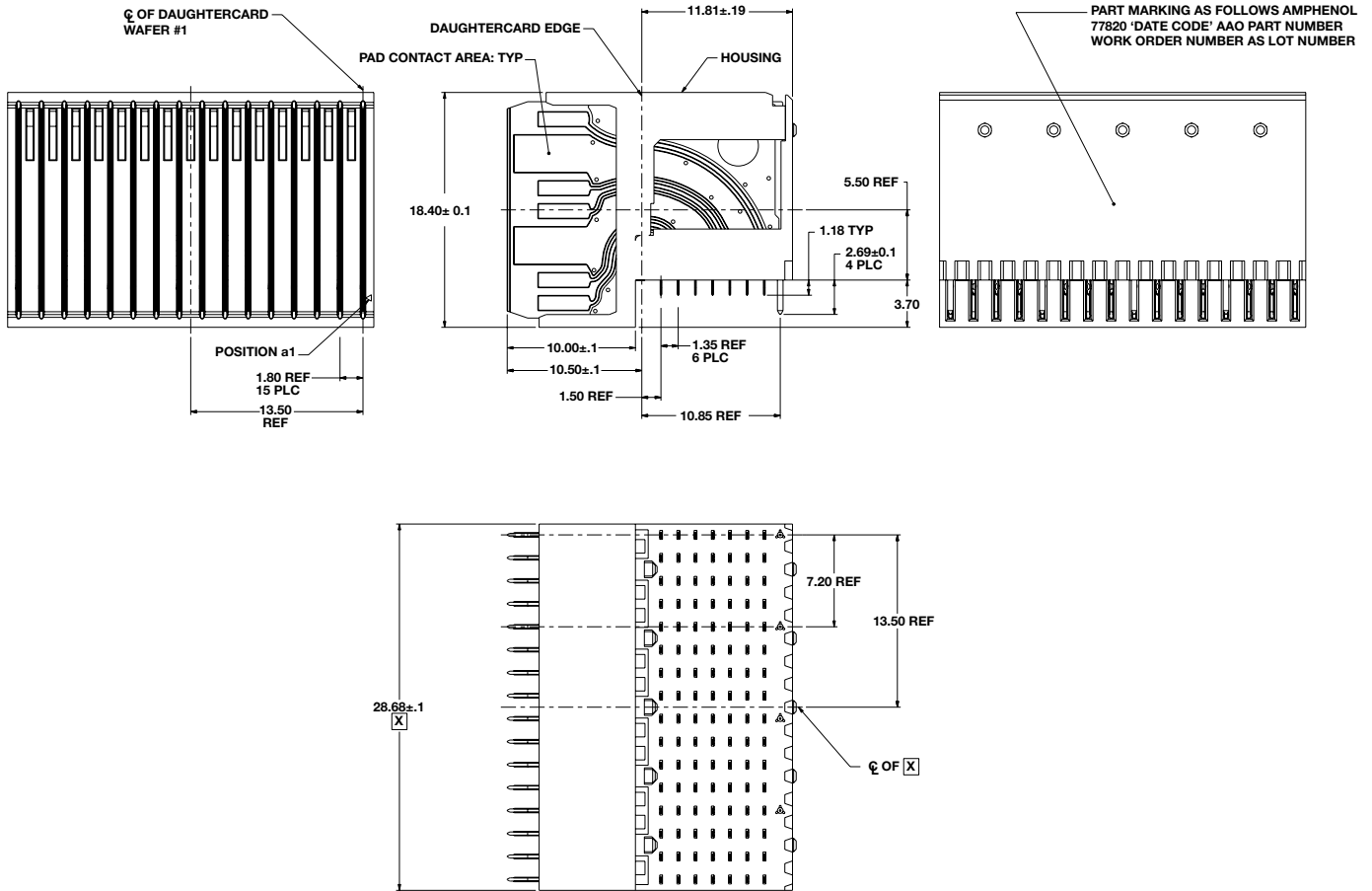

PLATING THICKNESS AND MATERIAL BY PART NUMBER				
	Part Number	Gold In Contact Area	Compliant Contact Termination Finish	Nickel Overall
EVO 1 16 Gpbs	RVPX-PE16DM1	50 µ-Inch min.	Tin	50 µ-Inch Min.
	RVPX-PE16DM2		Tin-lead	
	RVPX-PE16DC1	30 µ-Inch min.	Tin	
	RVPX-PE16DC2		Tin-lead	
EVO 2 32 Gpbs	RVPX-PE216DM1	50 µ-Inches min.	Tin	50 µ-Inches min.
	RVPX-PE216DM2		Tin-Lead	
	RVPX-PE216DC1	30 µ-Inches min	Tin	
	RVPX-PE216DC2		Tin-Lead	

BACKPLANE EVOLUTION 2: 16 Position Middle Backplane

R-VPX EVO

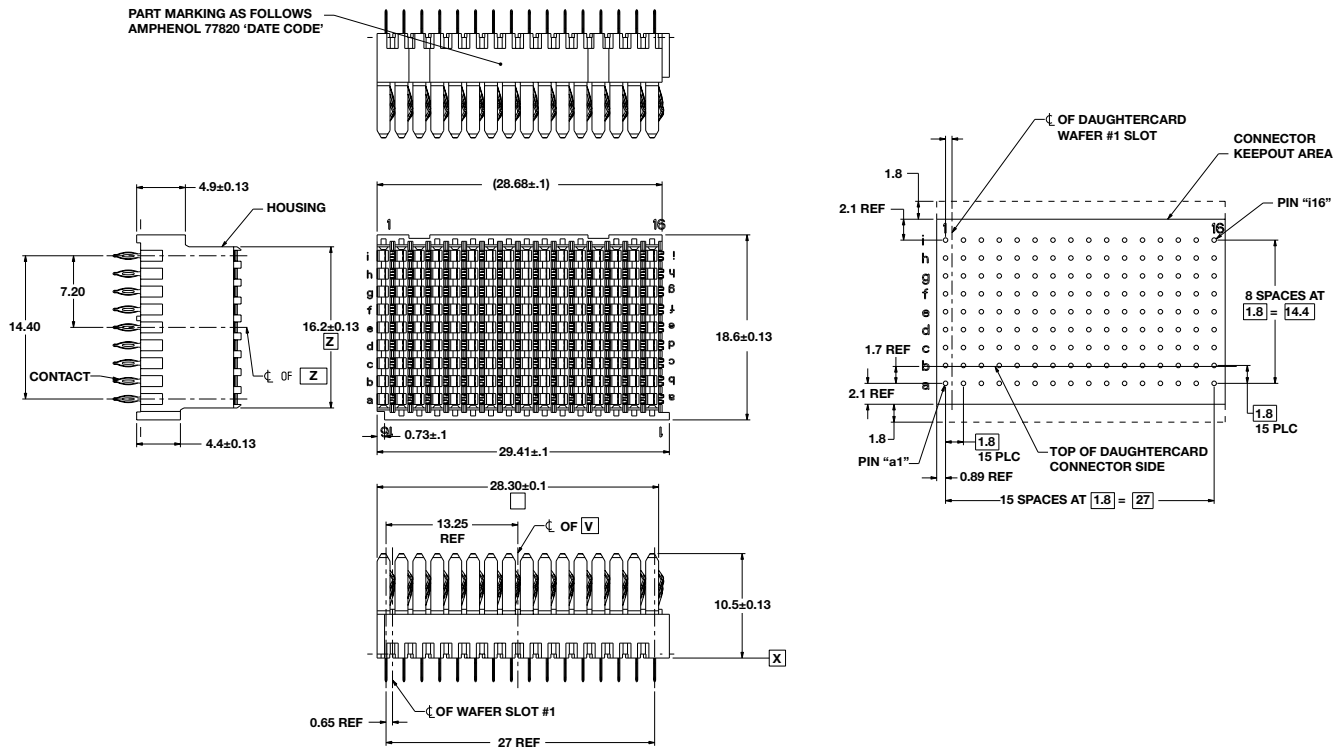

PLATING THICKNESS AND MATERIAL BY PART NUMBER			
Part Number	Gold In Contact Area	Compliant Contact Termination Finish	Nickel Overall
RVPX-JE216MM1	50 µ-Inch min.	Tin	50 µ-Inch Min.
RVPX-JE216MM2		Tin-lead	
RVPX-JE216MC1	30 µ-Inch min.	Tin	
RVPX-JE216MC2		Tin-lead	

R-VPX REAR TRANSITION MODULE: Part Number List

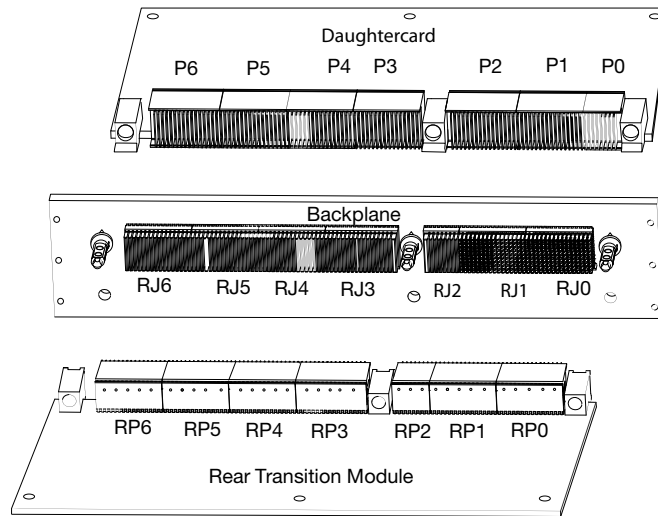

Part Number	Gender	Size	Insert Type	Plating	Contact Finish
RVPX-RP208DC1	RTM Module	8	RP2 Single-Ended	30 Micro-Inches	Tin
RVPX-RP208DC2	RTM Module	8	RP2 Single-Ended	30 Micro-Inches	Tin-Lead
RVPX-RP208DM1	RTM Module	8	RP2 Differential	50 Micro-Inches	Tin
RVPX-RP208DM2	RTM Module	8	RP2 Differential	50 Micro-Inches	Tin-Lead
RVPX-RP208SM1	RTM Module	8	RP2 Differential	50 Micro-Inches	Tin
RVPX-RP208SM2	RTM Module	8	RP2 Differential	50 Micro-Inches	Tin-Lead
RVPX-PE20815M2	RTM Module Evolution 2	8	RP2 Differential	50 Micro-Inches	Tin-lead
RVPX-PE20817M2	RTM Module Evolution 2	8	P0	50 Micro-Inches	Tin-lead
RVPX-RP208SC1	RTM Module	8	RP2 Differential	30 Micro-Inches	Tin
RVPX-RP208SC2	RTM Module	8	RP2 Differential	30 Micro-Inches	Tin-Lead
RVPX-RP016VC1	RTM Module	16	End - RP0	30 Micro-Inches	Tin
RVPX-RP016VC2	RTM Module	16	End - RP0	30 Micro-Inches	Tin-Lead
RVPX-RP016VM1	RTM Module	16	End - RP0	50 Micro-Inches	Tin
RVPX-RP016VM2	RTM Module	16	End - RP0	50 Micro-Inches	Tin-Lead
RVPX-RP116DC1	RTM Module	16	RP1 Differential	30 Micro-Inches	Tin
RVPX-RP116DC2	RTM Module	16	RP1 Differential	30 Micro-Inches	Tin-Lead
RVPX-RP116DM1	RTM Module	16	RP1 Differential	50 Micro-Inches	Tin
RVPX-RP116DM2	RTM Module	16	RP1 Differential	50 Micro-Inches	Tin-Lead
RVPX-RP116DSC1	RTM Module	16	RP1 Differential & Single-Ended	30 Micro-Inches	Tin
RVPX-RP116DSC2	RTM Module	16	RP1 Differential & Single-Ended	30 Micro-Inches	Tin-Lead
RVPX-RP116DSM1	RTM Module	16	RP1 Differential & Single-Ended	50 Micro-Inches	Tin
RVPX-RP116DSM2	RTM Module	16	RP1 Differential & Single-Ended	50 Micro-Inches	Tin-Lead
RVPX-RP116DC1	RTM Module	16	RP3-RP6 Differential	30 Micro-Inches	Tin
RVPX-RP116DC2	RTM Module	16	RP3-RP6 Differential	30 Micro-Inches	Tin-Lead
RVPX-RP116DM1	RTM Module	16	RP3-RP6 Differential	50 Micro-Inches	Tin
RVPX-RP116DM2	RTM Module	16	RP3-RP6 Differential	50 Micro-Inches	Tin-Lead
RVPX-PE216DM2	RTM Module Evolution 2	16	P1 - P6 Differential	50 Micro-Inches	Tin-lead
RVPX-PE21609M2	RTM Module Evolution 2	16	P0 + P1A Hybrid Power & Signal	50 Micro-Inches	Tin-lead
RVPX-PE21613M2	RTM Module Evolution 2	16	RP0 Mixed Signal & Power	50 Micro-Inches	Tin-lead

R-VPX REAR TRANSITION MODULE: Part Number List

Part Number	Gender	Size	Insert Type	Plating	Contact Finish
RVPX-PE21614M2	RTM Module Evolution 2	16	RP1, RP3-RP6 Differential	50 Micro-Inches	Tin-lead
RVPX-P16SC1	RTM Module	16	RP3-RP6 Single Ended	30 Micro-Inches	Tin
RVPX-P16SC2	RTM Module	16	RP3-RP6 Single Ended	30 Micro-Inches	Tin-Lead
RVPX-P16SM1	RTM Module	16	RP3-RP6 Single Ended	50 Micro-Inches	Tin
RVPX-P16SM2	RTM Module	16	RP3-RP6 Single Ended	50 Micro-Inches	Tin-Lead
RVPX-J08EC1	RTM Backplane	8	RJ2 End	30 Micro-Inches	Tin
RVPX-J08EC2	RTM Backplane	8	RJ2 End	30 Micro-Inches	Tin-Lead
RVPX-J08EM1	RTM Backplane	8	RJ2 End	50 Micro-Inches	Tin
RVPX-J08EM2	RTM Backplane	8	RJ2 End	50 Micro-Inches	Tin-Lead
RVPX-JE20818M2	RTM Backplane Evolution 2	8	J0	50 Micro-Inches	Tin-lead
RVPX-JE208MM2	RTM Backplane Evolution 2	8	RJ2	50 Micro-Inches	Tin-lead
RVPX-RJ0116MC1	RTM Backplane	16	RJ0 15 Columns of contacts	30 Micro-Inches	Tin
RVPX-RJ0116MC2	RTM Backplane	16	RJ0 15 Columns of contacts	30 Micro-Inches	Tin-Lead
RVPX-RJ0116MM1	RTM Backplane	16	RJ0 15 Columns of contacts	50 Micro-Inches	Tin
RVPX-RJ0116MM2	RTM Backplane	16	RJ0 15 Columns of contacts	50 Micro-Inches	Tin-Lead
RVPX-RJ0216MC1	RTM Backplane	16	RJ0 7 Columns of contacts	30 Micro-Inches	Tin
RVPX-RJ0216MC2	RTM Backplane	16	RJ0 7 Columns of contacts	30 Micro-Inches	Tin-Lead
RVPX-RJ0216MM1	RTM Backplane	16	RJ0 7 Columns of contacts	50 Micro-Inches	Tin
RVPX-RJ0216MM2	RTM Backplane	16	RJ0 7 Columns of contacts	50 Micro-Inches	Tin-Lead
RVPX-J16MC1	RTM Backplane	16	RJ1 16 Columns of contacts	30 Micro-Inches	Tin
RVPX-J16MC2	RTM Backplane	16	RJ1 16 Columns of contacts	30 Micro-Inches	Tin-Lead
RVPX-J16MM1	RTM Backplane	16	RJ1 16 Columns of contacts	50 Micro-Inches	Tin
RVPX-J16MM2	RTM Backplane	16	RJ1 16 Columns of contacts	50 Micro-Inches	Tin-Lead
RVPX-RJ1216MC1	RTM Backplane	16	RJ1 8 Columns of contacts	30 Micro-Inches	Tin
RVPX-RJ1216MC2	RTM Backplane	16	RJ1 8 Columns of contacts	30 Micro-Inches	Tin-Lead
RVPX-RJ1216MM1	RTM Backplane	16	RJ1 8 Columns of contacts	50 Micro-Inches	Tin
RVPX-RJ1216MM2	RTM Backplane	16	RJ1 8 Columns of contacts	50 Micro-Inches	Tin-Lead
RVPX-JE216MM2	RTM Backplane Evolution 2	16	Full center J1, J3, J4, J5, RJ4, RJ5, RJ6	50 Micro-Inches	Tin-lead
RVPX-J16EC1	RTM Backplane	16	RJ3 End	30 Micro-Inches	Tin
RVPX-J16EC2	RTM Backplane	16	RJ3 End	30 Micro-Inches	Tin-Lead
RVPX-J16EM1	RTM Backplane	16	RJ3 End	50 Micro-Inches	Tin
RVPX-J16EM2	RTM Backplane	16	RJ3 End	50 Micro-Inches	Tin-Lead
RVPX-JE216EM2	RTM Backplane Evolution 2	16	Full right end J2, J6, RJ3	50 Micro-Inches	Tin-lead
RVPX-JE21610M2	RTM Backplane Evolution 2	16	RJ0	50 Micro-Inches	Tin-lead
RVPX-JE21611M2	RTM Backplane Evolution 2	16	RJ0	50 Micro-Inches	Tin-lead
RVPX-JE21612M2	RTM Backplane Evolution 2	16	RJ1	50 Micro-Inches	Tin-lead
RVPX-JE21616M2	RTM Backplane Evolution 2	16	J0 + J1A Hybrid Power & Signal	50 Micro-Inches	Tin-lead
RVPX-J16MC1	RTM Backplane	16	RJ4-RJ6	30 Micro-Inches	Tin
RVPX-J16MC2	RTM Backplane	16	RJ4-RJ6	30 Micro-Inches	Tin-Lead
RVPX-J16MM1	RTM Backplane	16	RJ4-RJ6	50 Micro-Inches	Tin
RVPX-J16MM2	RTM Backplane	16	RJ4-RJ6	50 Micro-Inches	Tin-Lead
RVPX-JE216MM2	RTM Backplane Evolution 2	16	RJ1	50 Micro-Inches	Tin-lead

REAR TRANSITION MODULE: Right Angle Plug Assembly, Half Left End, Daughtercard Differential

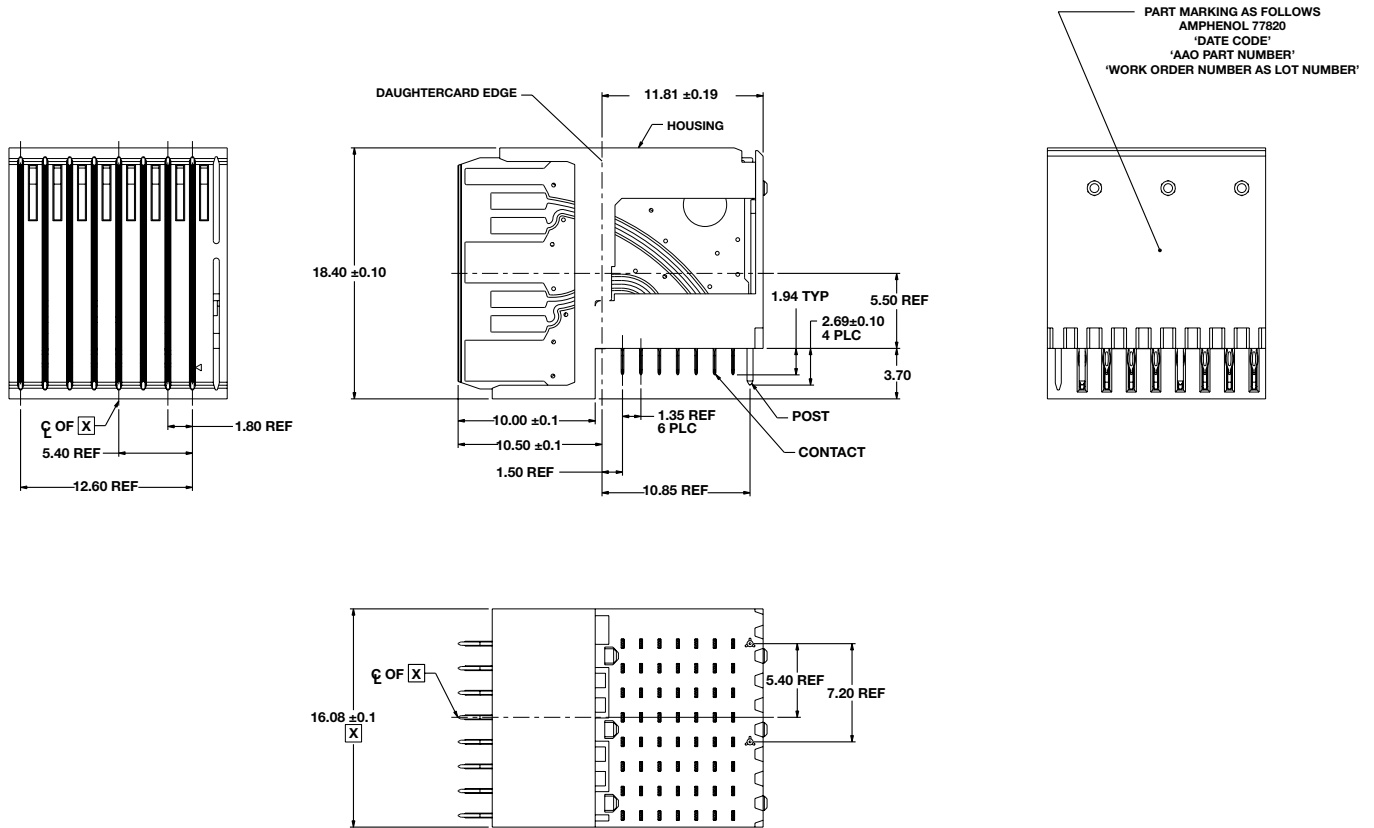

PLATING THICKNESS AND MATERIAL BY PART NUMBER

Part Number	Gold In Contact Area	Compliant Contact Termination Finish	Nickel Overall
RVPX-RP208DM1	50 μ-Inch min.	Tin	50 μ-Inch Min.
RVPX-RP208DM2		Tin-lead	
RVPX-RP208DC2	30 μ-Inch min.	Tin	
RVPX-RP208DC2		Tin-lead	

REAR TRANSITION MODULE: Right Angle Plug Assembly, Center RVPX Daughtercard Differential

R-VPX

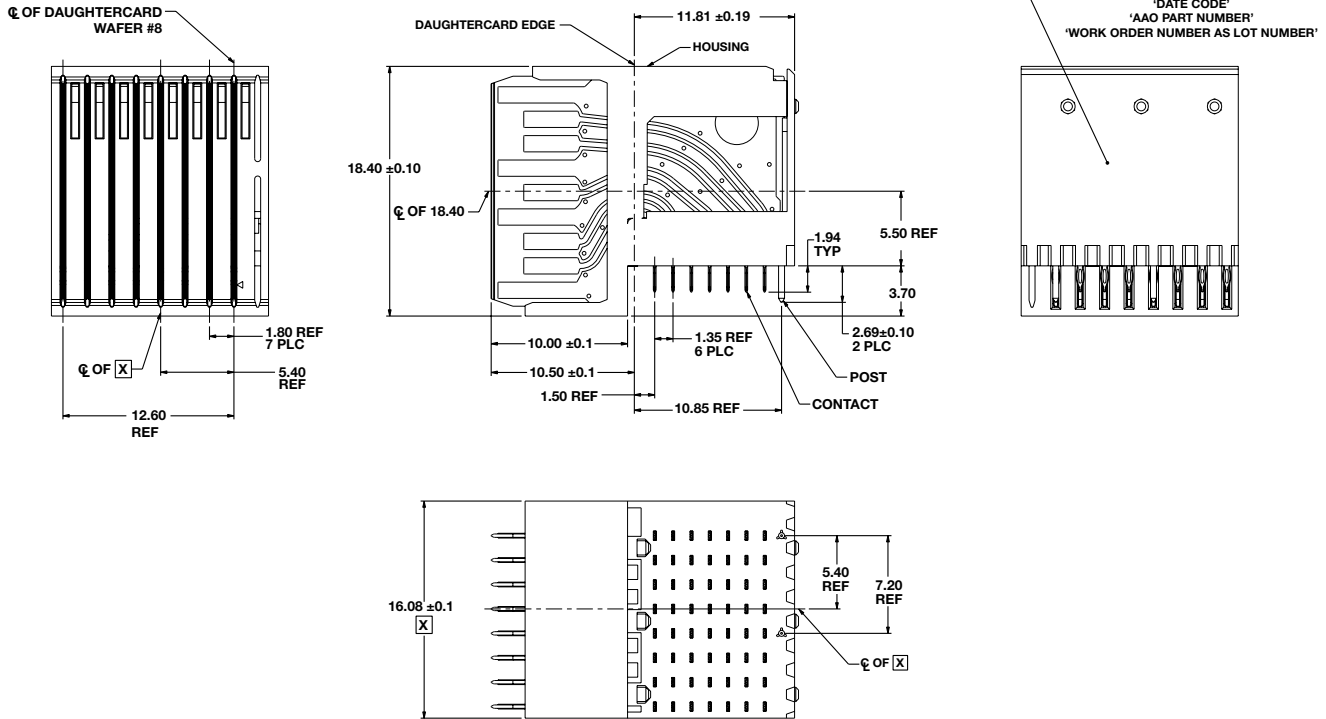

PLATING THICKNESS AND MATERIAL BY PART NUMBER			
Part Number	Gold In Contact Area	Compliant Contact Termination Finish	Nickel Overall
RVPX-RP208SM1	50 μ-Inch min.	Tin	50 μ-Inch Min.
RVPX-RP208SM2		Tin-lead	
RVPX-RP208SC1	30 μ-Inch min.	Tin	
RVPX-RP208SC2		Tin-lead	

REAR TRANSITION MODULE: Right Angle Plug Assembly, Center RVPX Daughtercard

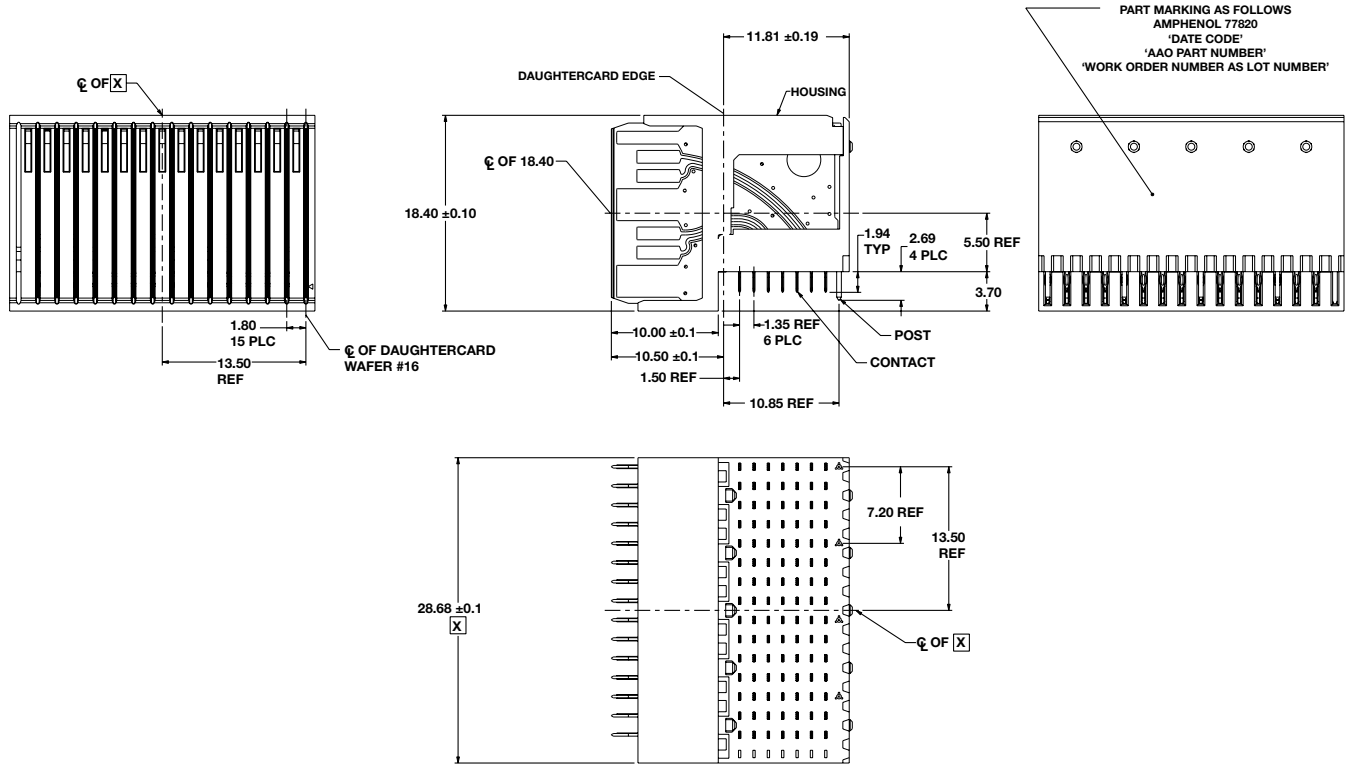

PLATING THICKNESS AND MATERIAL BY PART NUMBER

Part Number	Gold In Contact Area	Compliant Contact Termination Finish	Nickel Overall
RVPX-RP016VM1	50 µ-Inch min.	Tin	50 µ-Inch Min.
RVPX-RP016VM2		Tin-lead	
RVPX-RP016VC1	30 µ-Inch min.	Tin	
RVPX-RP016VC2		Tin-lead	

REAR TRANSITION MODULE: Right Angle Plug Assembly, Center RVPX Daughtercard Differential

R-VPX

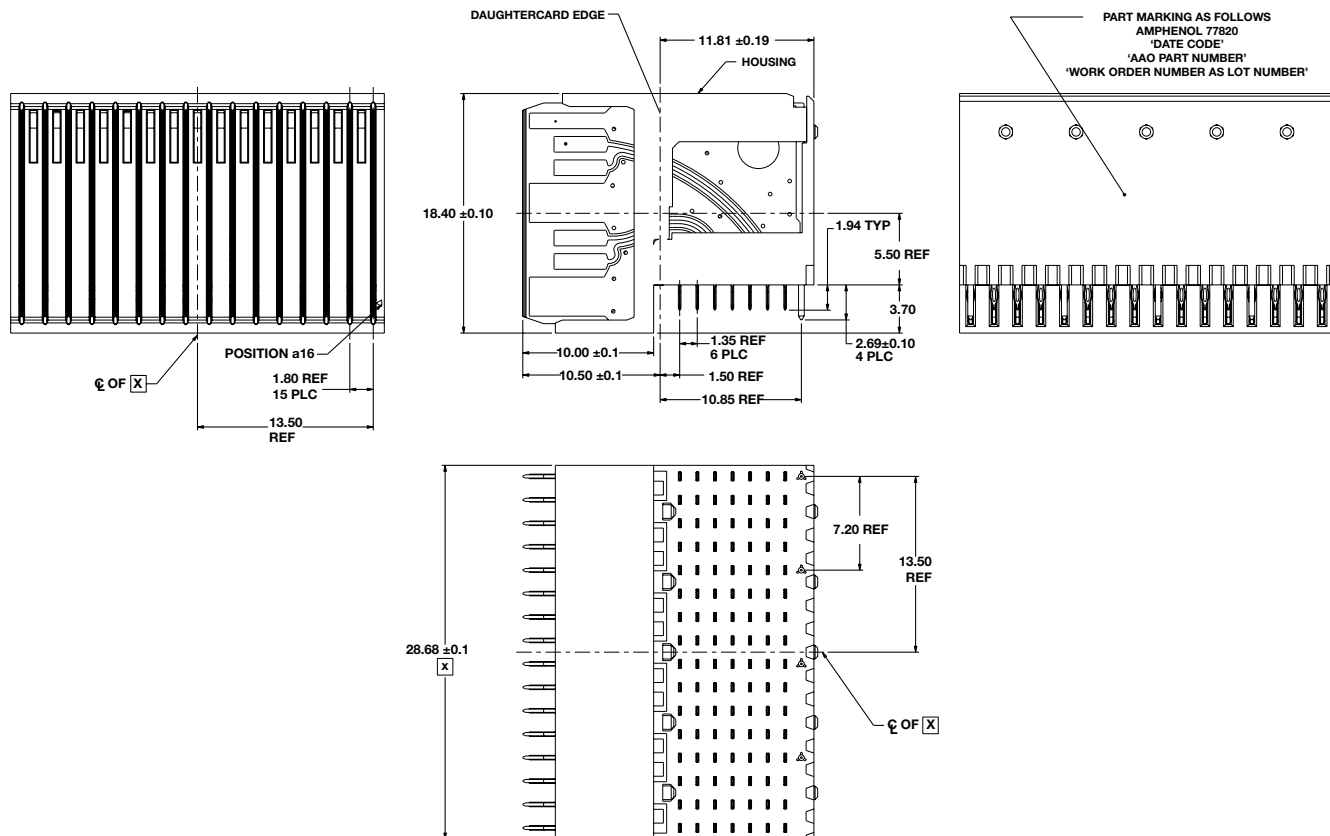

PLATING THICKNESS AND MATERIAL BY PART NUMBER			
Part Number	Gold In Contact Area	Compliant Contact Termination Finish	Nickel Overall
RVPX-RP116DM1	50 μ -Inch min.	Tin	50 μ -Inch Min.
RVPX-RP116DM2		Tin-lead	
RVPX-RP116DC1	30 μ -Inch min.	Tin	
RVPX-RP116DC2		Tin-lead	

REAR TRANSITION MODULE: Right Angle Plug Assembly, Center RVPX Daughtercard Differential-SE

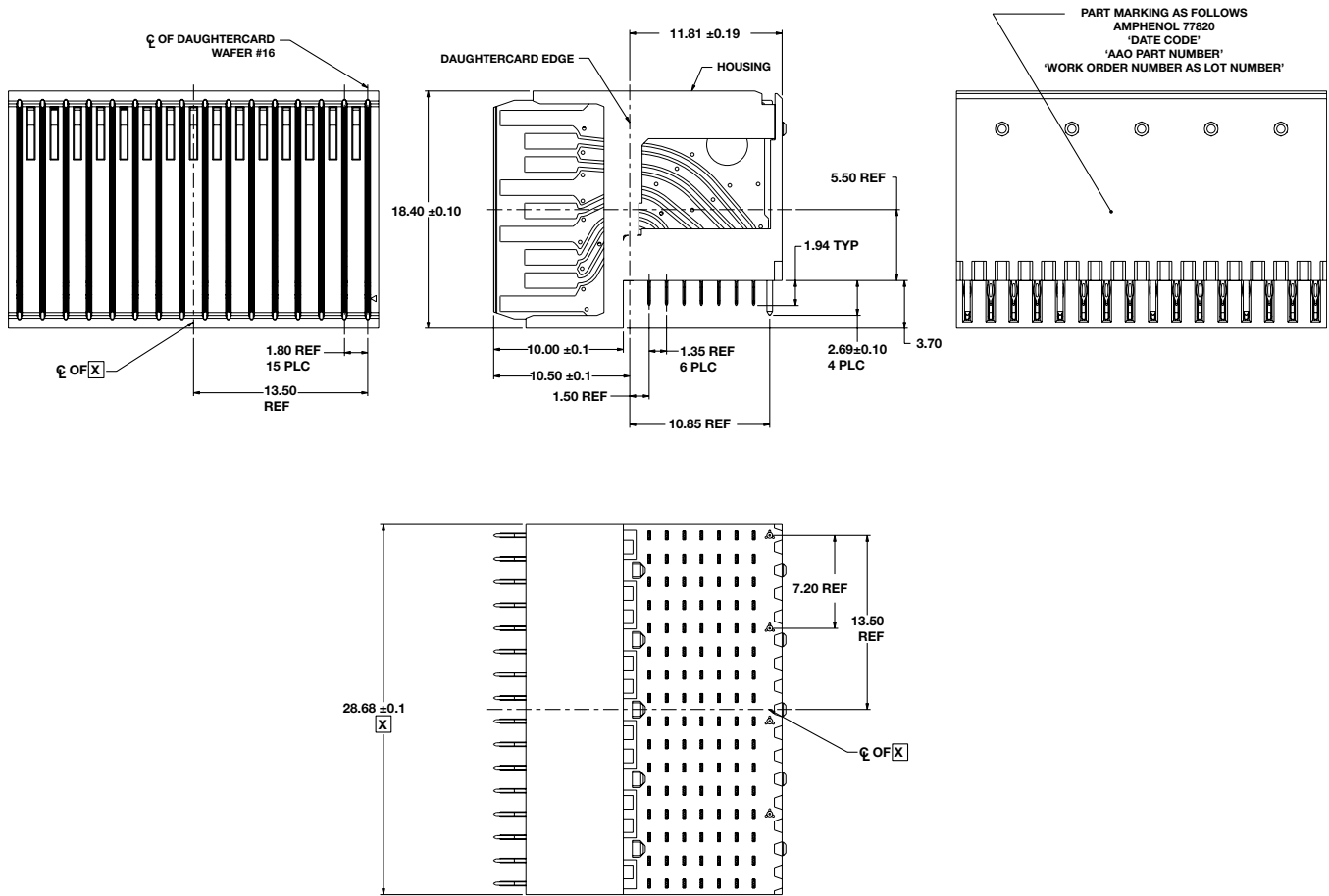

PLATING THICKNESS AND MATERIAL BY PART NUMBER

Part Number	Gold In Contact Area	Compliant Contact Termination Finish	Nickel Overall
RVPX-RP116DSM1	50 µ-Inch min.	Tin	50 µ-Inch Min.
RVPX-RP116DSM2		Tin-lead	
RVPX-RP116DSC1	30 µ-Inch min.	Tin	
RVPX-RP116DSC2		Tin-lead	

BACKPLANE: Rear Transition Module Center

R-VPX

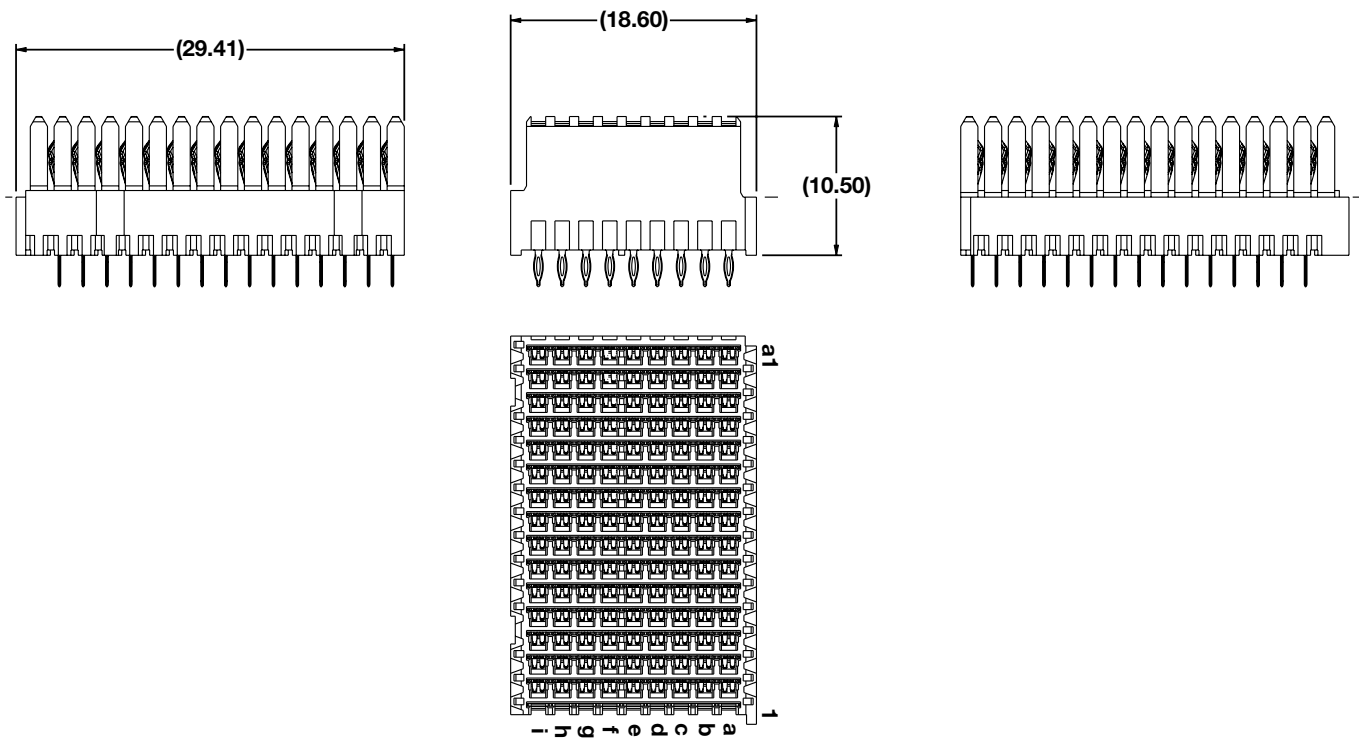

PLATING THICKNESS AND MATERIAL BY PART NUMBER

Part Number	Gold In Contact Area	Compliant Contact Termination Finish	Nickel Overall
RVPX-RJ0116MM1M	50 μ -Inch min.	Tin	50 μ -Inch Min.
RVPX-RJ0116MM2M		Tin-lead	
RVPX-RJ0116MC1M	30 μ -Inch min.	Tin	
RVPX-RJ0116MC2M		Tin-lead	

BACKPLANE: Rear Transition Module Vertical Receptacle Center, Partial Load

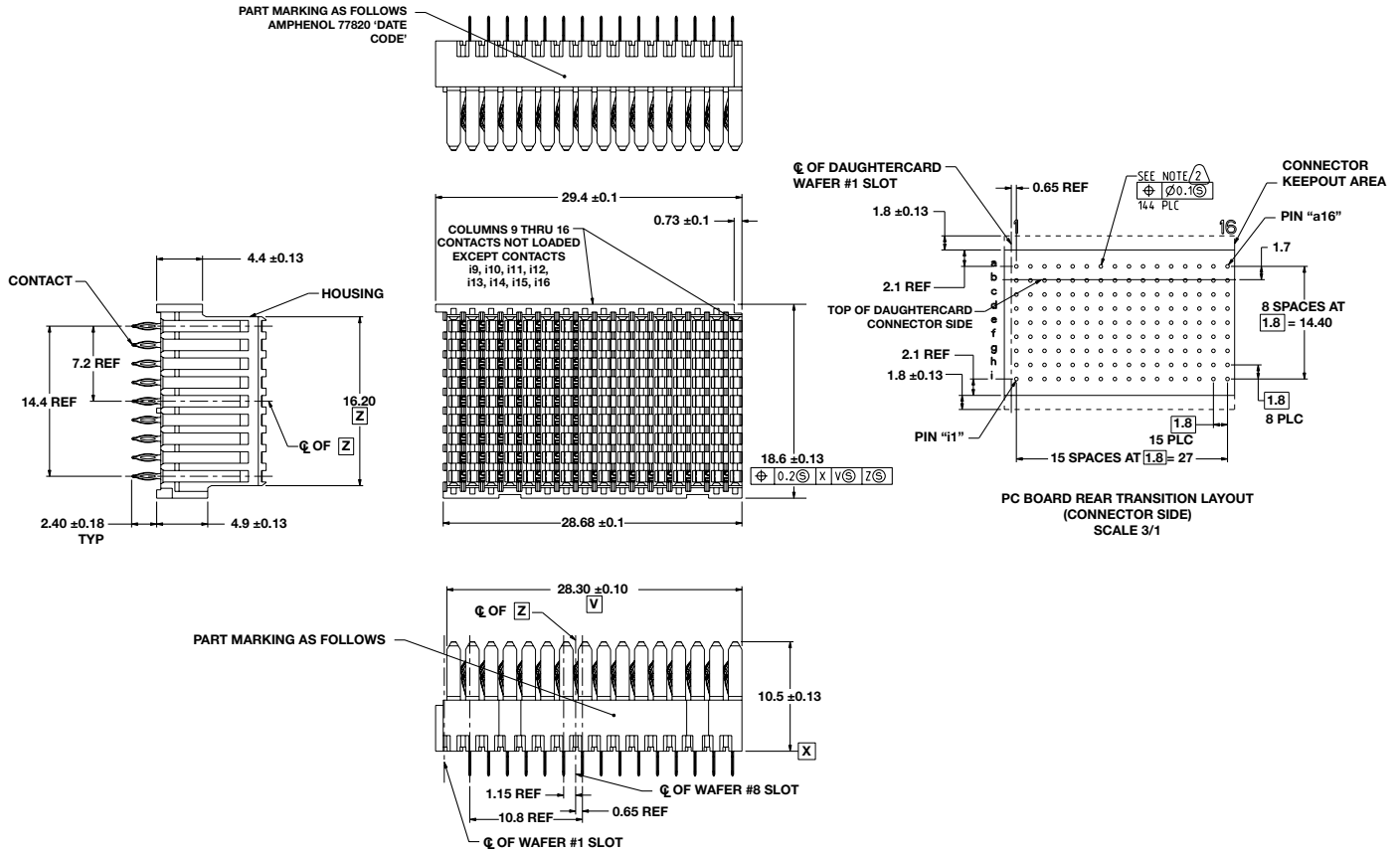

PLATING THICKNESS AND MATERIAL BY PART NUMBER

Part Number	Gold In Contact Area	Compliant Contact Termination Finish	Nickel Overall
RVPX-RJ0216MM1	50 μ-Inch min.	Tin	50 μ-Inch Min.
RVPX-RJ0216MM2		Tin-lead	
RVPX-RJ0216MC1	30 μ-Inch min.	Tin	
RVPX-RJ0216MC2		Tin-lead	

BACKPLANE: Rear Transition Module Vertical Receptacle Center, Partial Load

R-VPX

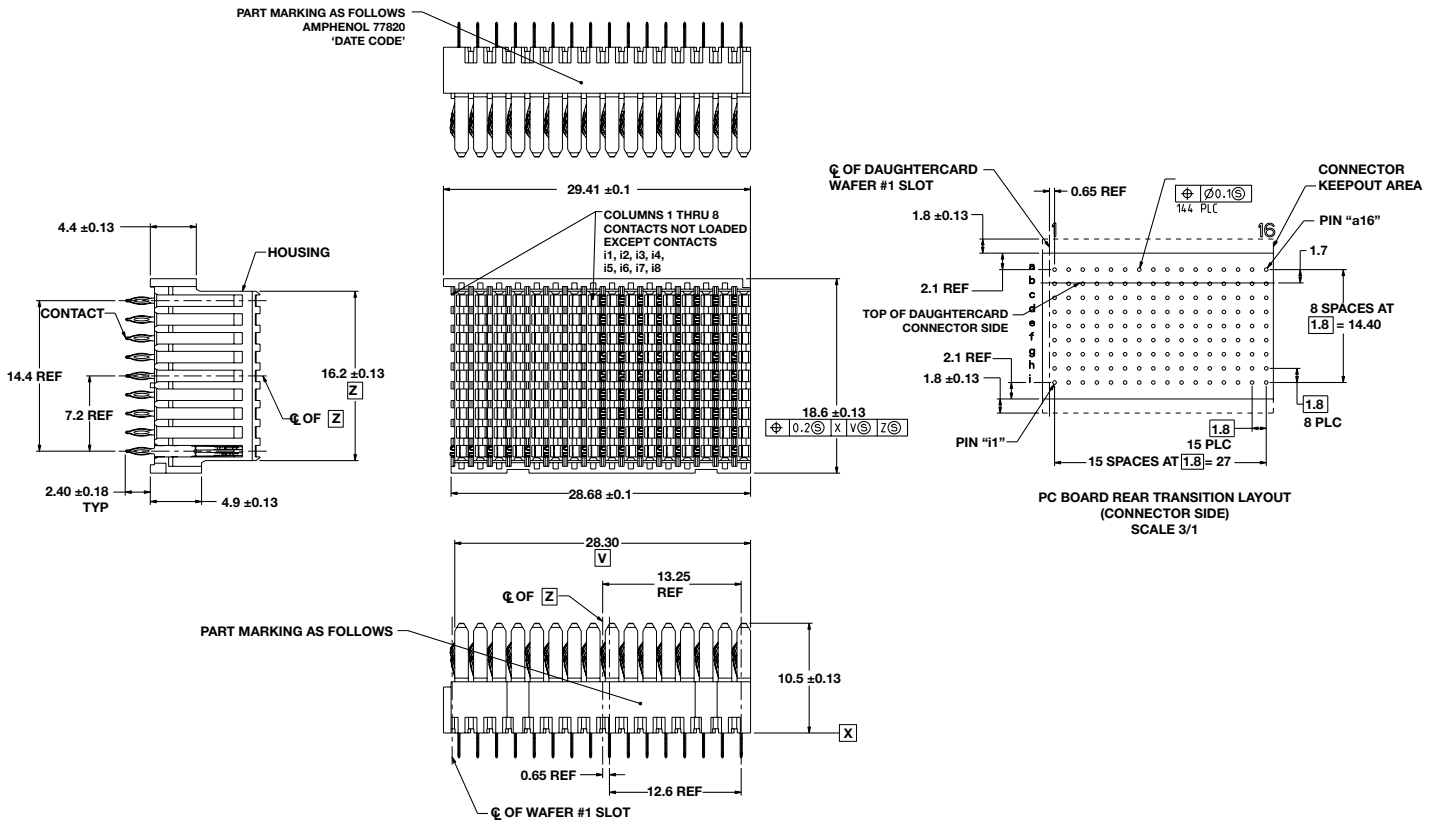

PLATING THICKNESS AND MATERIAL BY PART NUMBER

Part Number	Gold In Contact Area	Compliant Contact Termination Finish	Nickel Overall
RVPX-RJ1216MM1	50 μ -Inch min.	Tin	50 μ -Inch Min.
RVPX-RJ1216MM2		Tin-lead	
RVPX-RJ1216MC1	30 μ -Inch min.	Tin	
RVPX-RJ1216MC2		Tin-lead	

HARDWARE: Zinc Die Cast Guide Modules

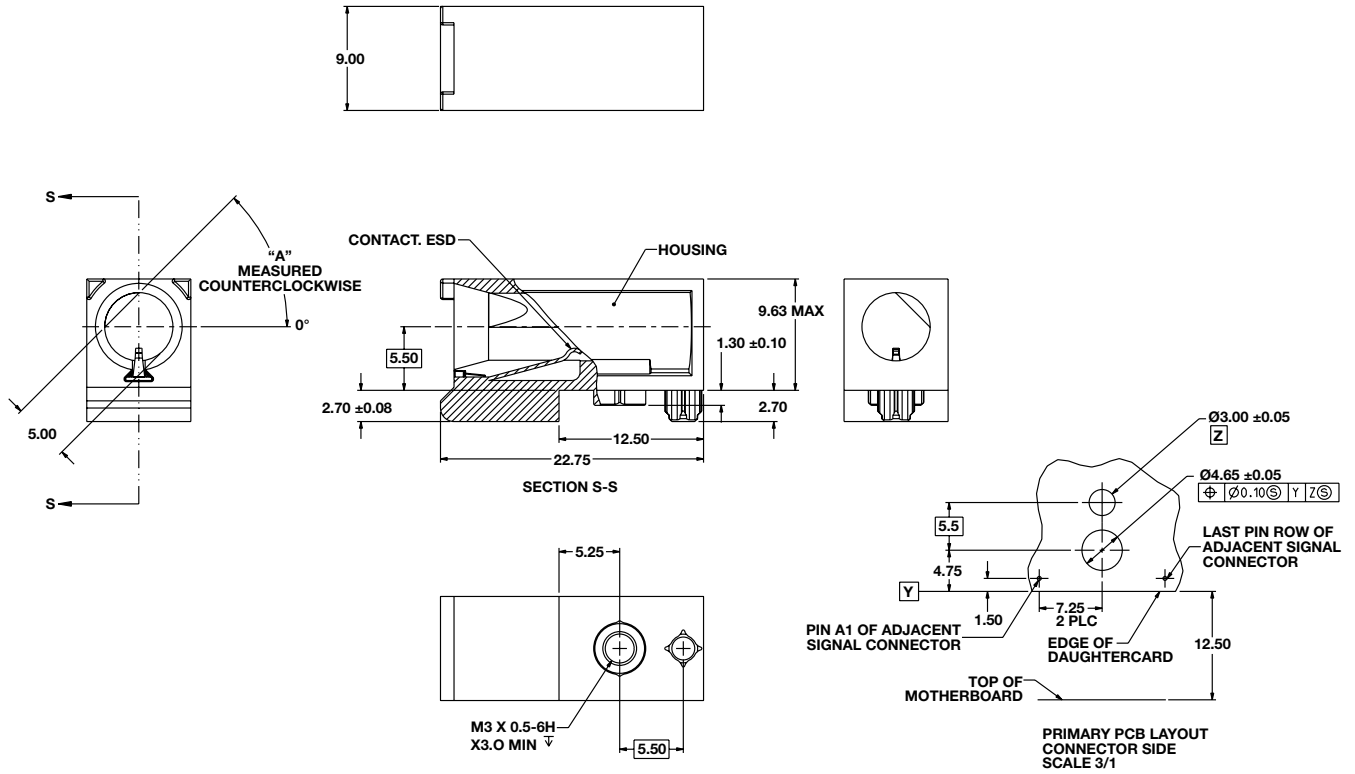

ZINC DIE CAST GUIDE MODULES	
Part Number	DIM. A
RVPX-HMD-1	0
RVPX-HMD-2	45
RVPX-HMD-3	90
RVPX-HMD-7	270
RVPX-HMD-8	315
RVPX-HMD-9	Without Key

HARDWARE: Machined Aluminum Guide Modules

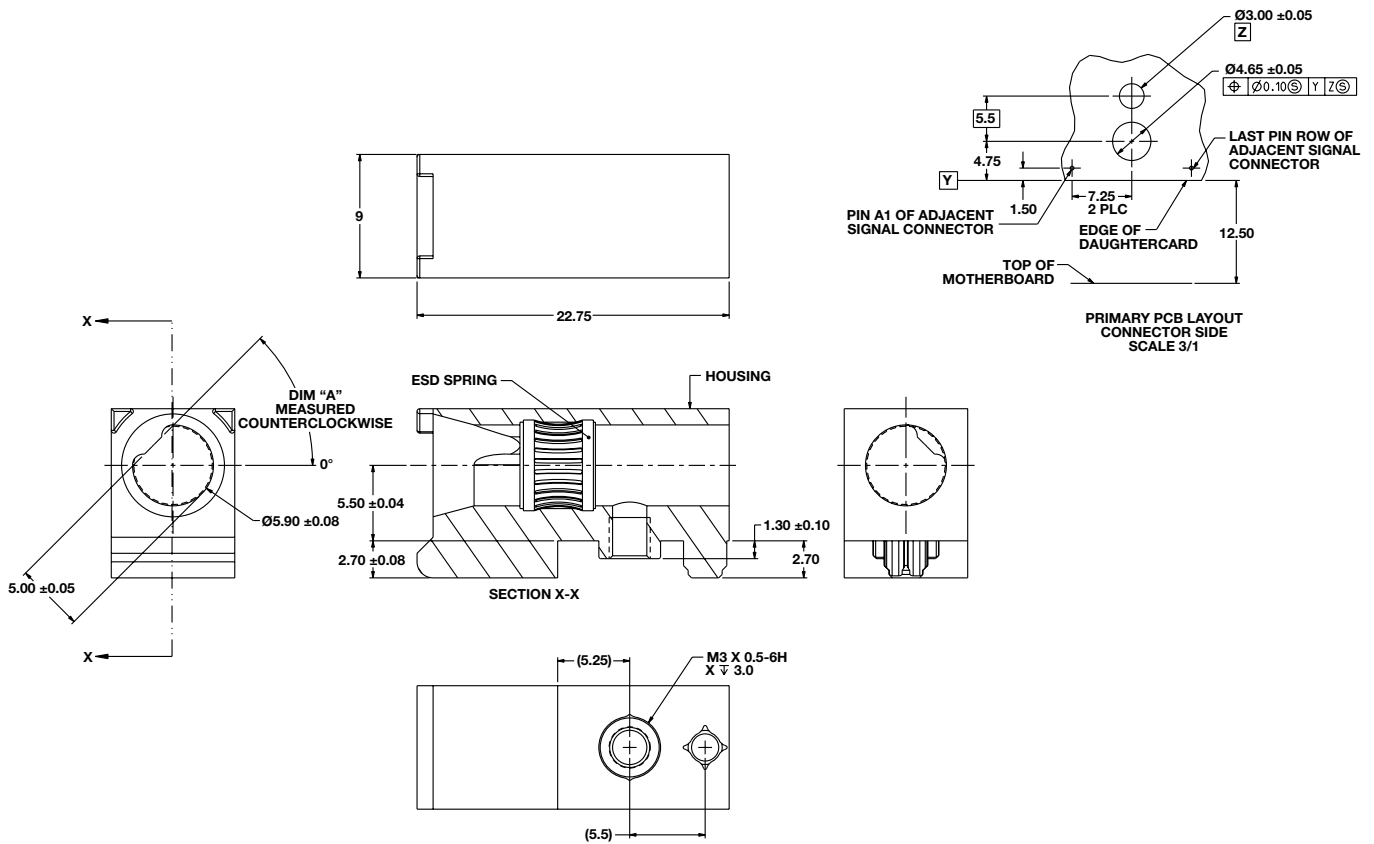

MACHINED ALUMINUM GUIDE MODULES			
Part Number	DIM. A	Material	Finish
RVPX-HMM-1	0	Aluminum	Electroless Nickel
RVPX-HMM-2	45		
RVPX-HMM-3	90		
RVPX-HMM-4	270		
RVPX-HMM-5	315		
RVPX-HMM-6	Without Key		
RVPX-HMM-7	0	Stainless Steel	Passivated Steel
RVPX-HMM-8	45		
RVPX-HMM-9	90		
RVPX-HMM-10	270		
RVPX-HMM-12	315		
RVPX-HMM-13	Without Key		

HARDWARE: Zinc Die Cast Guide Pins

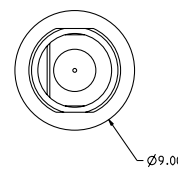
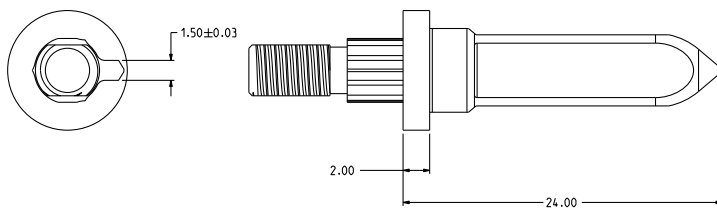
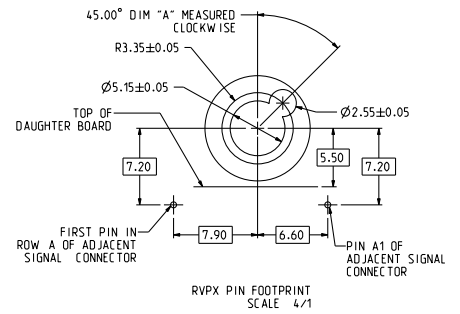
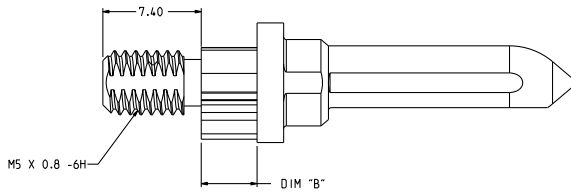

ZINC DIE CAST GUIDE PINS	
Part Number	DIM. B
RVPX-HPD-2	2.60
RVPX-HPD-3	4.20
RVPX-HPD-4	5.70

HARDWARE: Machined Stainless Steel Guide Pins

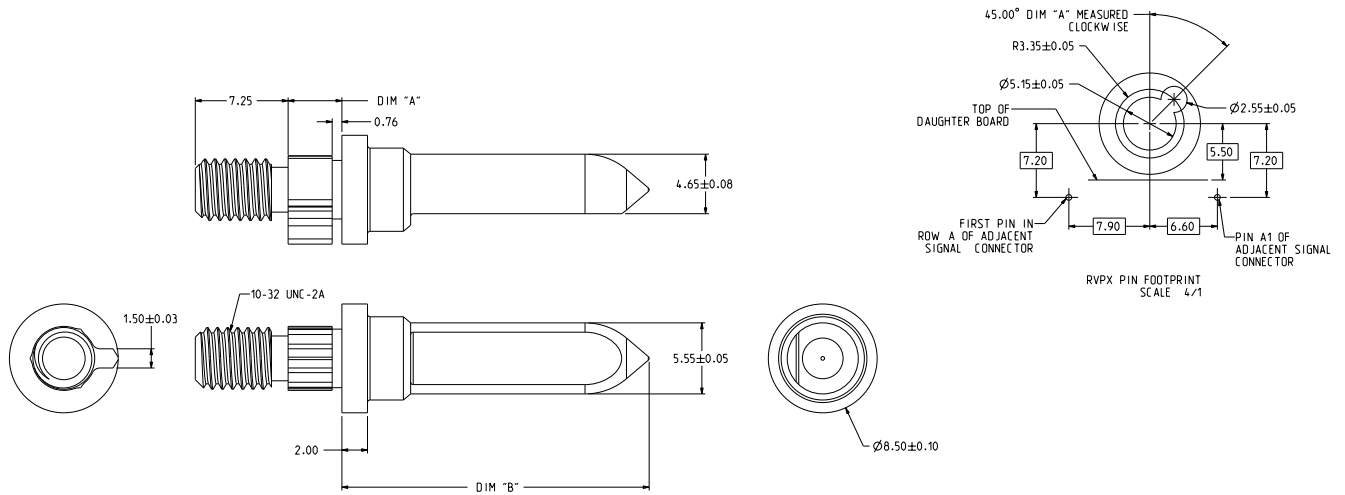

MACHINED STAINLESS STEEL GUIDE PINS

Part Number	DIM. A	DIM. B
RVPX-HPM-1	1.32	24.0
RVPX-HPM-2	2.60	24.0
RVPX-HPM-3	4.20	24.0
RVPX-HPM-4	5.70	24.0
RVPX-HPM-5	7.30	24.0
RVPX-HPM-10	1.32	19.0
RVPX-HPM-12	4.20	19.0
RVPX-HPM-13	5.70	19.0

INSTALLATION

The RVPX connector is designed for simple installation. A mechanical electric press or Arbor Press is used to compress the compliant pins into the plated thru holes seating the connector. Care should be taken to ensure even distribution of force across the housings. This can easily be achieved with the use of flat rock tooling.

When pressing the module assemblies, the connector over hangs the module board slightly. Because of this overhang, a support plate is needed to ensure the connector gets fully seated without bowing of the PCB.

Extraction tools are available and suggested for backplane connector removal. See page 38.

SUPPLEMENTAL DAUGHTERCARD RETENTION: (EVO1 & EVO2)

For systems which will encounter dynamic environments, use a bead of adhesive as illustrated. Amphenol has tested and qualified 3M Scotchweld 2216 with Amphenol daughtercards and FR4 PCBs. Alternate materials can also be used as approved by their materials engineers.

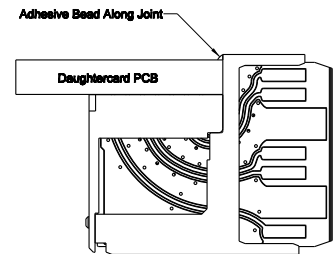

VISUAL AID

The illustration below shows a typical application of RVPX connectors. This illustration should be used by production personnel to ensure a correctly applied product.

MOUNTED CONNECTORS:

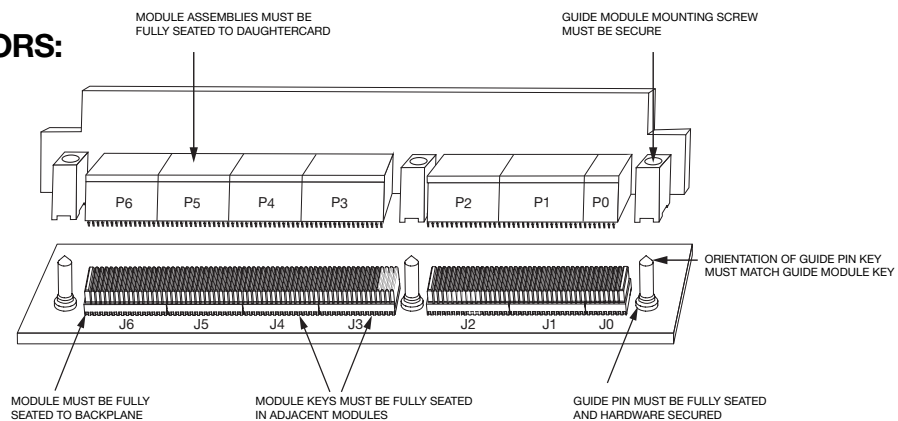

MATED CONNECTORS:

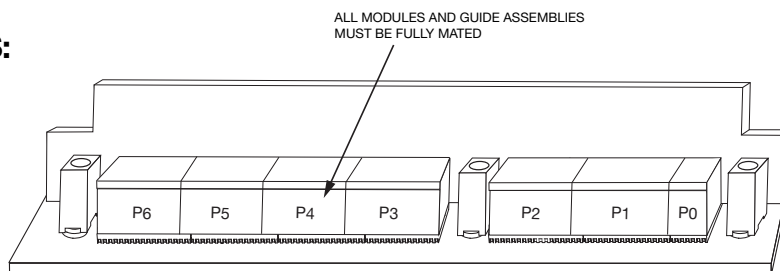

TOOLS: Backplane Connector Removal

BACKPLANE CONNECTOR REMOVAL

Amphenol has a two step process for backplane removal. First the backplane housing is removed using tool **10-743034-003** or **10-743034-001** for 8 and 16 position housings respectively.

The tool is placed around the housing with the fingers interlocking the base of the housing you would like to remove. Then the screw is turned until the housing comes off its contacts.

Second tool **10-743034-002** is used to remove the contacts. Gently place the comb under the last row of contacts and rock it back until the contacts come out of their holes. Repeat until all rows are removed.



ORDER GUIDE	
PART NUMBER	DESCRIPTION
10-743034-001	8 Position Connector Removal Tool
10-743034-003	16 Position Connector Removal Tool
10-743034-002	Contact Removal Comb Tool

SPACEVPX VITA 78 CONNECTOR

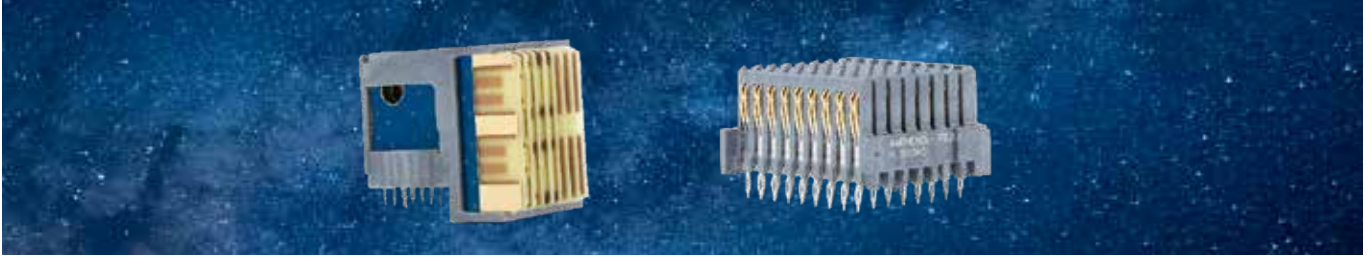

VITA 78 connectors, also known as SpaceVPX are specifically designed for use in space-based electronic systems. Amphenol's VITA 78 SpaceVPX connectors leverage OpenVPX architecture and technology and are designed and tested for extreme space environments, including exposure to radiation, extreme temperatures and vibration. SpaceVPX connectors utilize specific wafer loads per the VITA 78 spec to achieve dual redundancy to meet fault tolerance requirements for space systems.

Features & Benefits:

- Outgassing- third-party testing – meets NASA and European Space Agency (ESA) outgassing requirements.
- Vibration- 4-point backplane contact system for extreme vibration applications.
- Passed VITA 72 vibration level testing with BER monitoring.
- Compliant (press-fit) Pin Technology- tested with various PCB platings to verify performance and reliability.
- Current Capacity – power wafers and wafer configurations to support VITA 78 Space utility management modules.
- Extreme Temperature- tested to a temp range of -67 °F (-55 °C) to 221 °F (105 °C)
- Passed VITA 72 vibration level testing with BER monitoring.

How to Order VITA 78 SpaceVPX

Please refer to the tables below:

VITA 78 SpaceUM 3U	
Amphenol Part Number	Configuration Per VITA 78
RVPX-P0824MX	Module 8
RVPX-P1636xx	Module 16E
RVPX-P1626MX	Module 16B

VITA 78.1 PowerSX	
Amphenol Part Number	Configuration Per VITA 78
RVPX-P0837xx	Power SX P0
RVPX-P1638xx	Power SX P1
RVPX-P1639xx	Power SX P2

VITA 78 SpaceUM 6U	
Amphenol Part Number	Configuration Per VITA 78
RVPX-P0824MX	Module 8
RVPX-P1625MX	Module 16A
RVPX-P1626MX	Module 16B
RVPX-P1627MX	Module 16C
RVPX-P1627MX	Module 16D
RVPX-P1625MX	Module 16A
RVPX-P1626MX	Module 16B

VITA 78 Power Supply	
Amphenol Part Number	Configuration Per VITA 78
RVPX-P08VMx	Standard P0 VITA 46 Load
RVPX-P1640xx	Power Supply P1

MIL-HD2

NEXT-GEN SOSA™/VITA 91 ALIGNED CONNECTOR SERIES

MIL-HD2



Designed to achieve 56G PAM4 data rate requirements with higher density.

Developed in alignment with The Open Group Sensor Open Systems Architecture™ (SOSA) technical standard, MIL-HD2 provides developers with a readily available, robust open architecture solution for tighter card pitches and chassis designs where space requirements and density are critical. These connectors are available in 3-, 4-, and 6-pair configurations, providing the MIL-embedded market with the highest count of differential pairs available today in a 3U configuration at 56Gb/s PAM 4 speeds. This series was selected by the SOSA Consortium and provides a SOSA aligned solution for next-gen switch and payload card requirements enabling the MIL-embedded market to meet next-gen performance levels while still meeting COTS requirements.

FEATURES

- Configurations to meet SOSA/VITA 91 requirements for HD Switch
- 4 diff, 8 column - SOSA aligned configuration
- Data rates scalable to 56Gb/s PAM4 to support system upgrades without costly redesigns
- Proprietary crosstalk reducing technologies
- 15.7mil drill compliant pin allows deeper backdrilling
- Optimized footprints
- Shielded contacts mate before signal contacts, providing up to a 4mm minimum wipe
- Embedded capacitor available
- Differential pairs 28-84 per inch (11-33 differential pairs per centimeter)

BENEFITS

- Highest density with 1.80mm pitch
- Proven EMI and signal integrity advantages
- Improved impedance matching
- Complete solution for unique customer requirements
- Enables hot plugging
- Meets high density application requirements

TECHNICAL INFORMATION

MATERIAL

- Contact Finish Area: Gold
- Contact Base Metal: High performance copper alloy
- Housings: LCP
- Stiffener: Stainless steel type 301

ELECTRICAL PERFORMANCE

- Signal Contact Current Rating: 1A
- Contact Resistance Change: 10mΩ max.
- Dielectric Withstanding Voltage: 750V RMS peak

MECHANICAL PERFORMANCE

- 2mm & 3mm signal wipes available
- Housing Capture: 0.8mm X & 0.61mm Y
- Guide Capture: 2mm X & Y
- Durability: 250 mating cycles

ENVIRONMENTAL

- Operating Temperature Range: -40°C to 105°C

APPROVALS AND CERTIFICATIONS

- UL94 V-0
- VITA 47 - Qualification testing in progress
- VITA 72 - Passed Vita 72 vibe levels

SPECIFICATIONS

- HD2 General Product Specification
- HD Family Routing Guidelines
- HD2 Connector Design Guidelines
- Vita 91

PACKAGING

- PVC trays (ESD)

TARGET MARKETS/APPLICATIONS

- Radar
- Sensors
- Switches
- Integrated Processors
- Surveillance
- Electronic Warfare
- Cyber Defense
- C5ISR
- Low Earth Orbit Satellites



ALIGNED CONNECTOR CONFIGURATIONS

MIL-HD2

**Module -4pr 8 Column, Extra Ground,
50u Gold, Tin & Lead Free**

3U Configuration Qty: 5

AAO Part Number: MHD24P800M1



**Backplane -4pr 8 Column, Extra Ground,
50u Gold, Tin & Lead Free**

3U Configuration Qty: 5

AAO Part Number: MHD24J800M1



HOW TO ORDER

Complete steps 1-7 to create your part number (ex: MHD24J800M1)

1.	2.	3.	4.	5.	6.	7.
Connector Type	Differential Pairs	Gender	Columns	Special Options	Contact Plating	Contact Termination Finish
MHD2	4	J	8	00	M	1

1. Connector Type	
MHD2	MIL-HD2 - (56 Gbps PAM4) Extra Ground Version *

3. Gender	
J	Backplane (without endwalls)
P	Daughtercard

6. Contact Plating	
M	50 μ-inch Gold

2. Differential Pairs	
3	Number of differential pairs per column
4	
6	

4. Columns	
4	Number of columns
6	
8	

7. Contact Termination Finish	
1	Gold (Tin & Lead Free)

5. Special Options	
00	Optional 2 digit indicator for specials (partial loads, etc.). Shall always be "00" when not used.

Required Installation Tools

10-743053-001	Backplane Installation Tool
10-743053-002	Daughter Card Installation Tool



Backplane Installation Tool

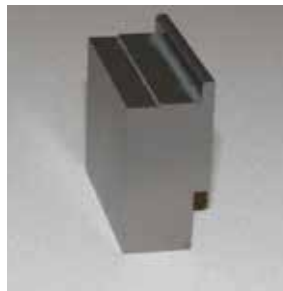

Daughtercard Installation Tool

OPTICAL FIBER RUGGEDIZED VITA 66.1 AND 66.4



Amphenol's VITA 66 family of products are ruggedized blind mate optical MT Module/Backplane connector systems designed to meet the VITA 66.1 and 66.4 open architecture specifications. These connectors are designed to provide a high density blind-mate optical solution via standard multi-mode MT ferrules and robust aluminum shells meeting VITA footprint requirements.

Optical Fiber Ruggedized VITA 66.1 & 66.4 are designed for embedded computing applications in :

VITA 66



Electronic Systems - C4ISR



Embedded Computing



Missile Defense



Ground Systems



Space Systems



Other Ruggedized Environments

OPTICAL FIBER VITA OVERVIEW

FEATURES AND BENEFITS:

- VITA 66.1, 66.4 spec compliant
- Supports up to two spring loaded floating MT ferrules
- Multiple alignment guide features
- No special tooling required for assembly
- Supports industry standard MT ferrules-up to 24 fiber optic channels per MT
- COTS
- Customs & derivatives : spring loaded, double density



VITA 66 RANGE

- VITA 66.1 : 2MT or Double density 4MT Standard or Spring loaded contacts
- VITA 66.4 : 1MT or Double density 2MT Standard or Spring loaded contacts

VITA 66

VPX Technology Roadmap

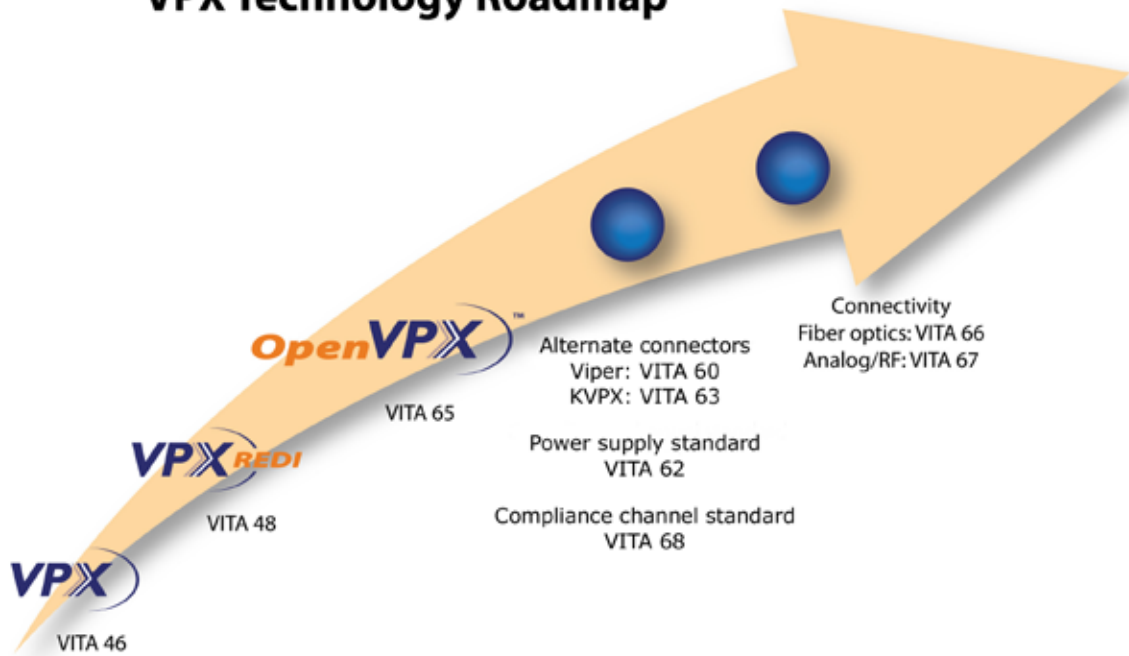

FIBER OPTIC VITA 66.1: Standard 2MT Backplane

PART NUMBER: 10-504639-002

(Dimensions in Inches)

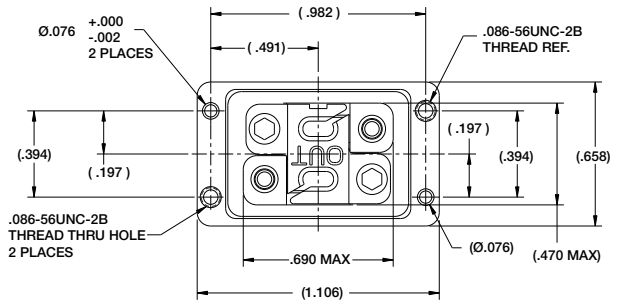
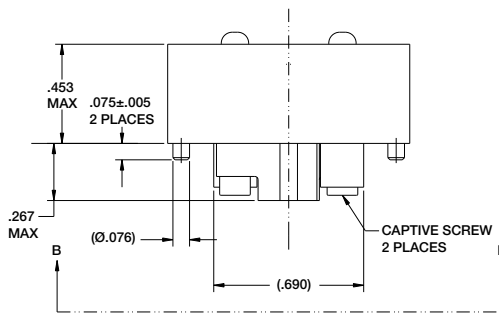
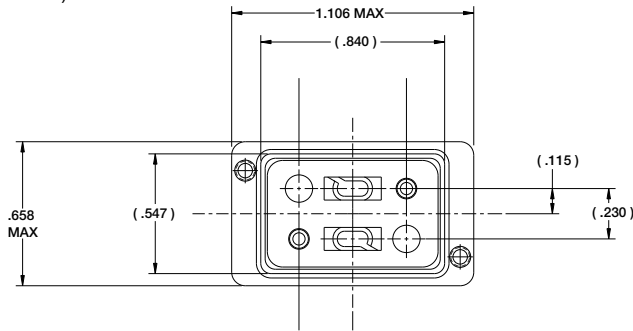

VITA 66.1

FIBER OPTIC VITA 66.1: Standard 2MT Module

PART NUMBER: 10-504637-004

(Dimensions in Inches)

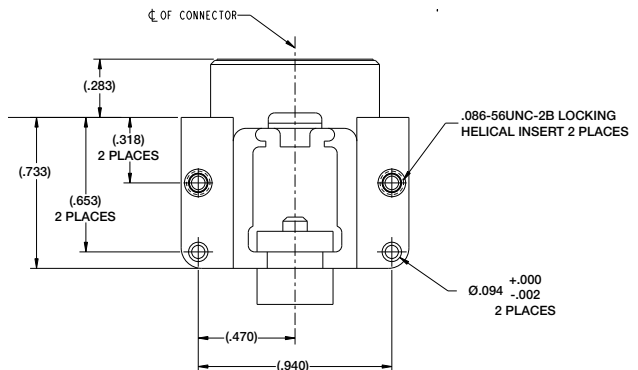
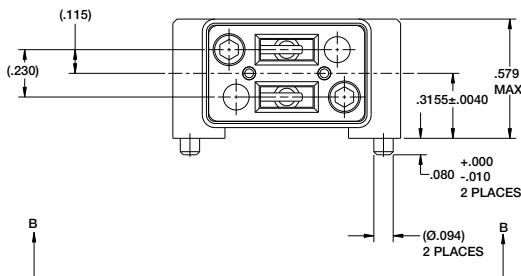
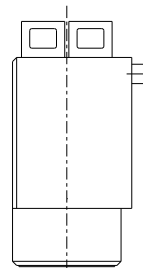
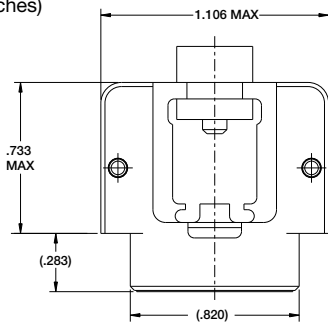

FIBER OPTIC VITA 66.1: Standard 2MT Installation & Assembly

VITA 66.1

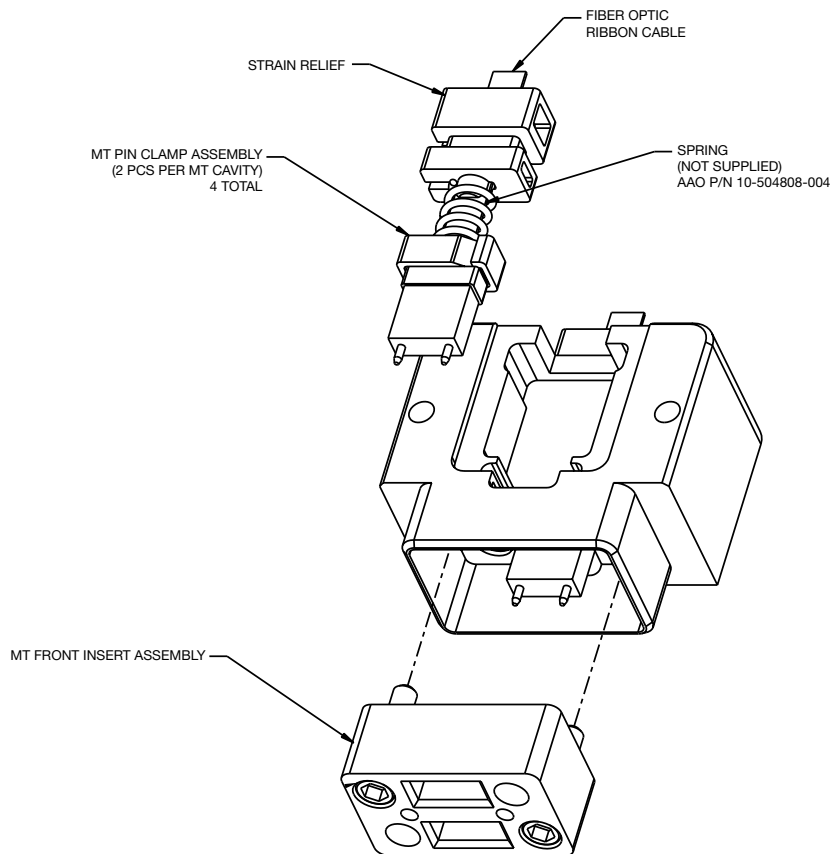
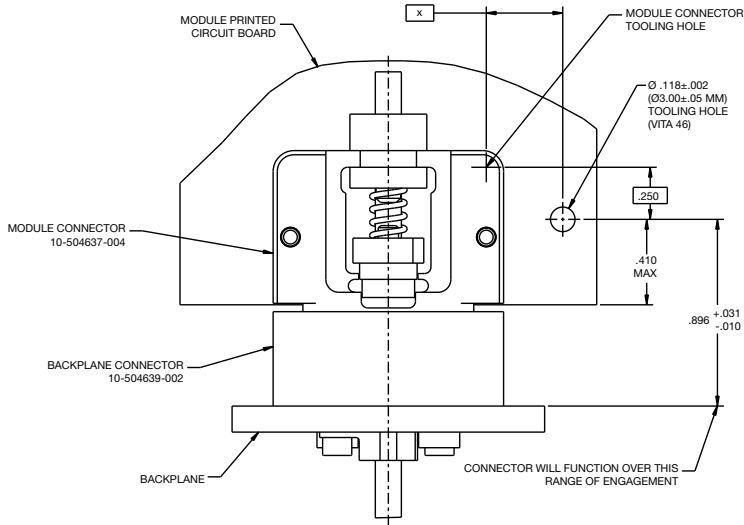

FIBER OPTIC VITA 66.1: Double Density 4MT Module

PART NUMBER: 10-504637-010

(Dimensions in MM)

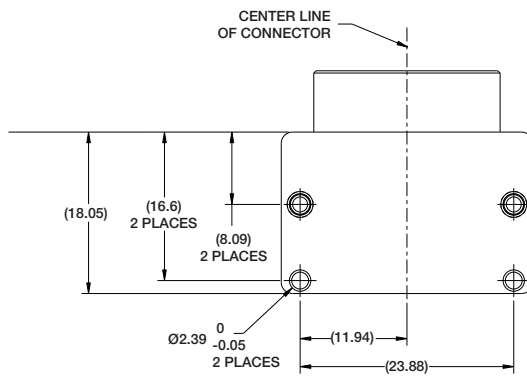
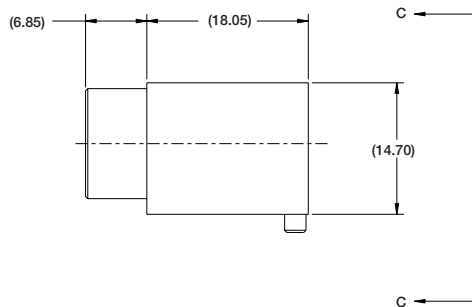
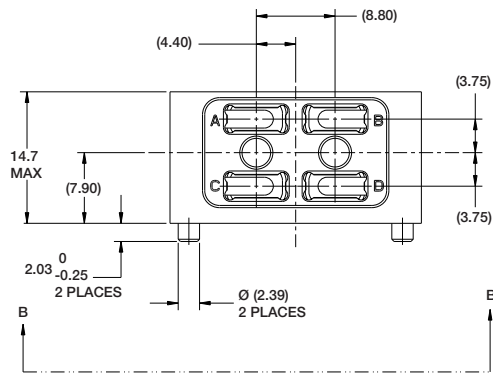
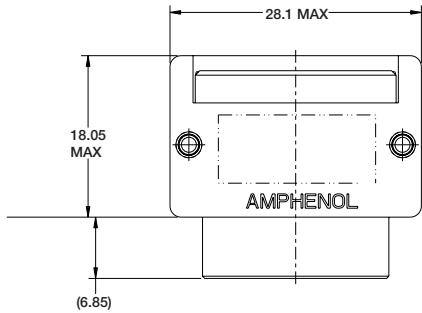

.086-56UNC-2B LOCKING
HELICAL INSERT 2 PLACES

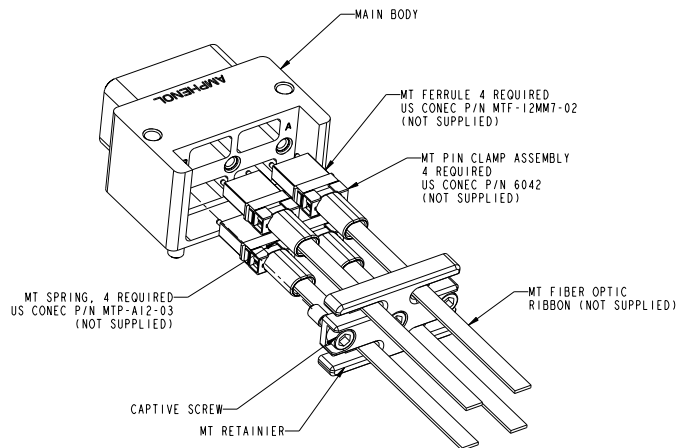
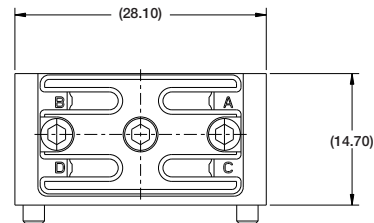

VITA 66.1

FIBER OPTIC VITA 66.1: 2MT Special Module

PART NUMBER: 10-504637-013

(Dimensions in MM)

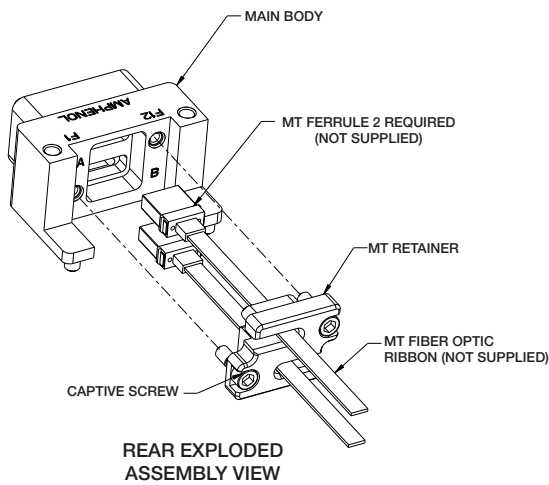
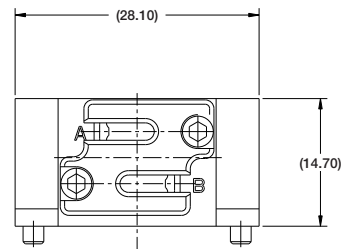
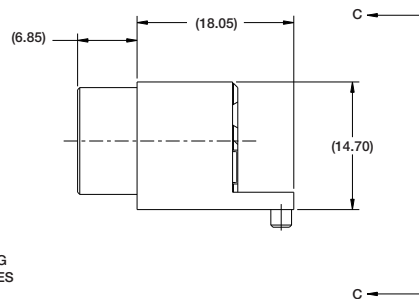
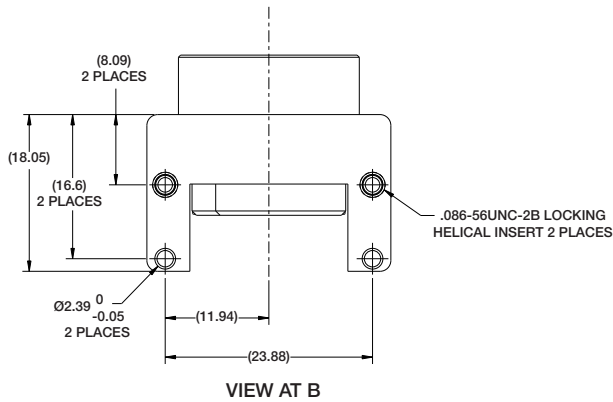
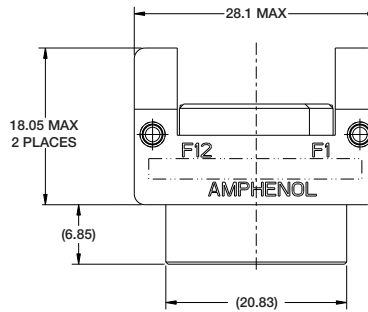
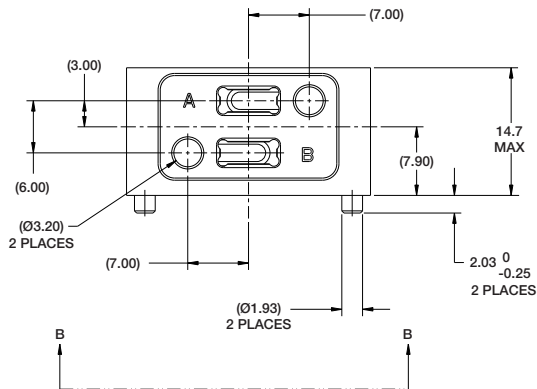

VITA 66.1

FIBER OPTIC VITA 66.1: 2MT Spring Loaded Backplane

PART NUMBER: 10-504639-011

(Dimensions in MM)

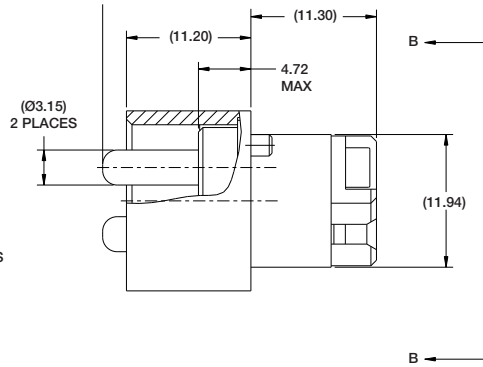
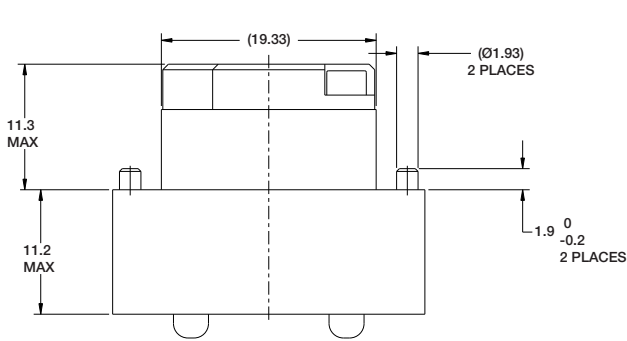

VITA 66.1

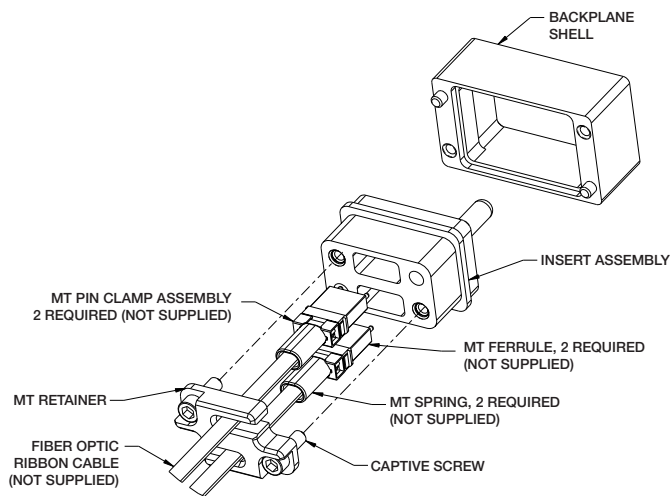
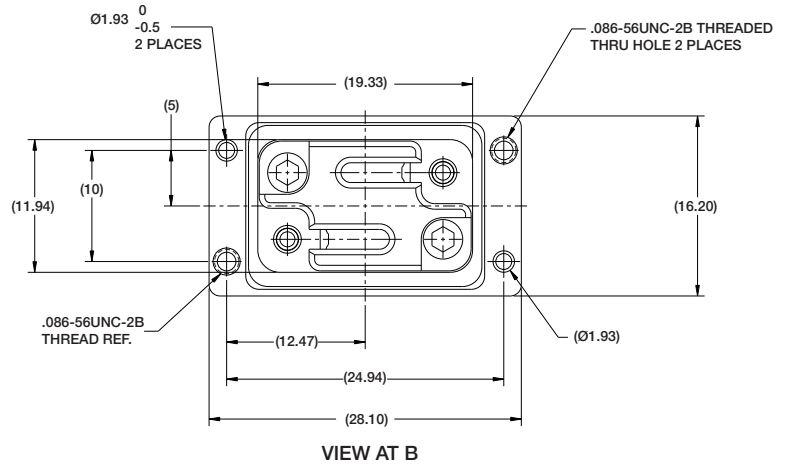
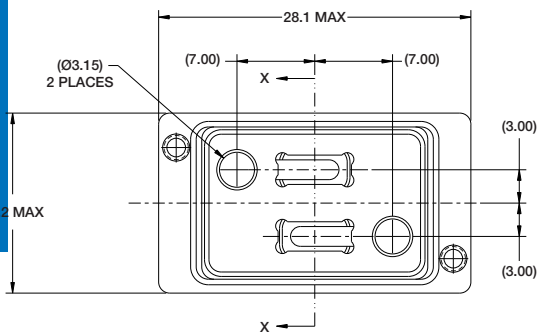

REAR EXPLODED ASSEMBLY VIEW
SCALE 3.000



FIBER OPTIC VITA 66.4: Standard 1MT Module

PART NUMBER: 10-504637-008

(Dimensions in MM)

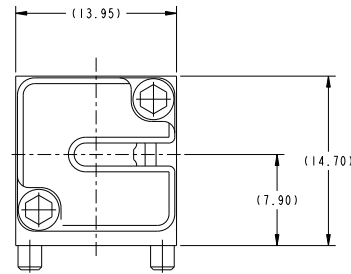
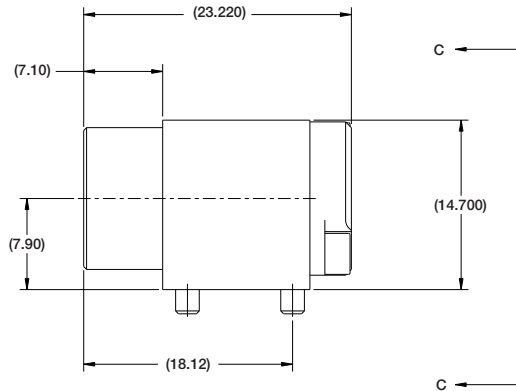

VIEW AT C

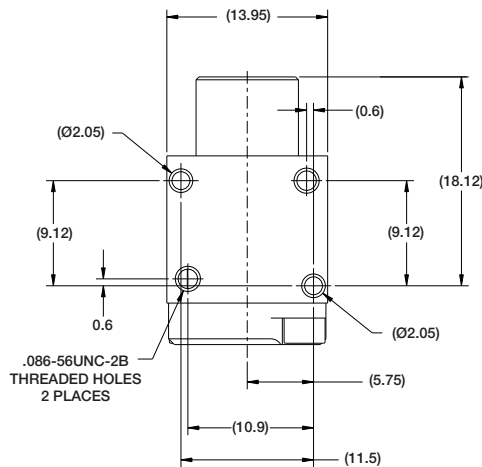
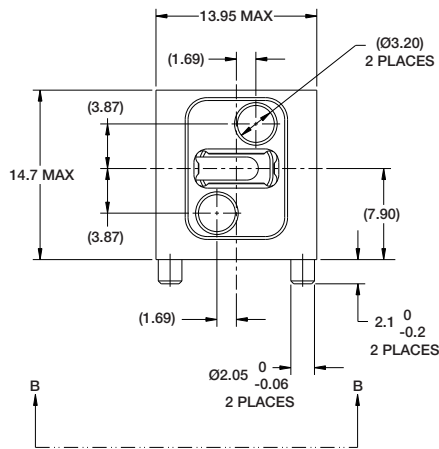

VIEW AT B

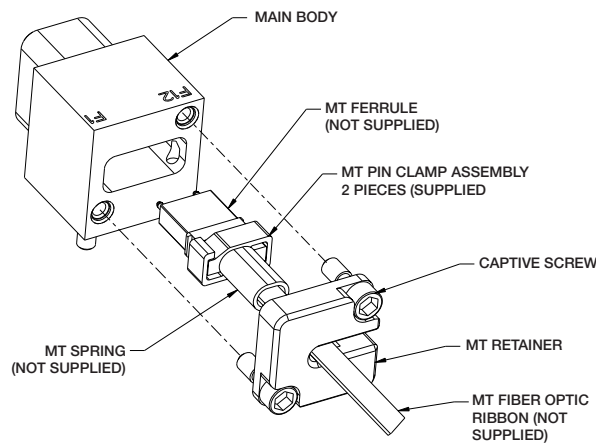
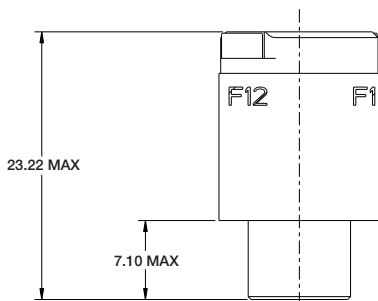

REAR EXPLODED
ASSEMBLY VIEW

VITA 66.4

FIBER OPTIC VITA 66.4: Standard 1MT Backplane

PART NUMBER: 10-504639-006

(Dimensions in MM)

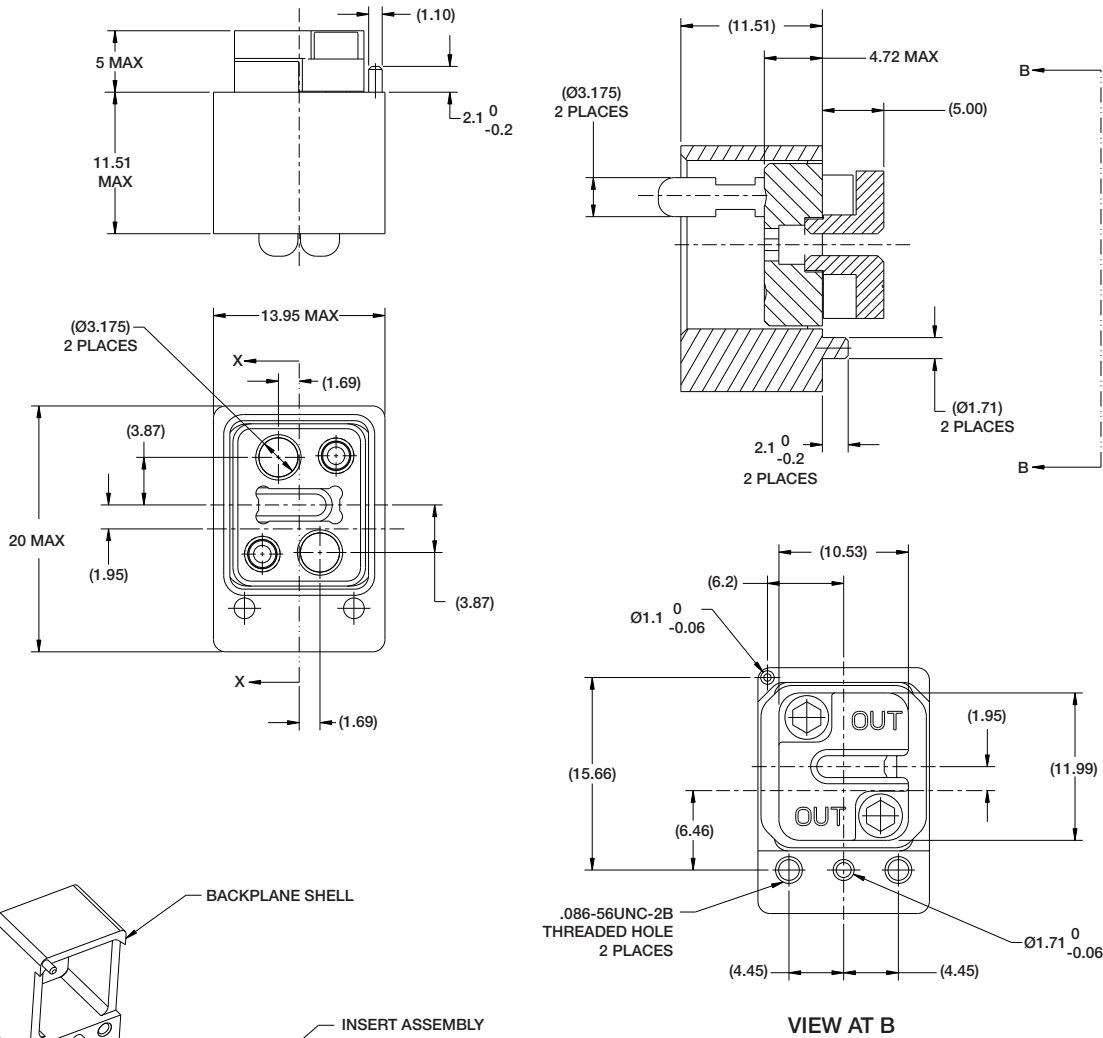

VITA 66.4

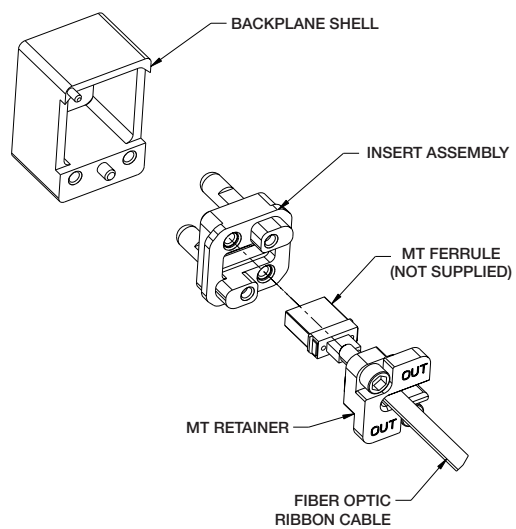

FIBER OPTIC VITA 66.4: 1MT Special Module

PART NUMBER: 10-504637-012

(Dimensions in MM)

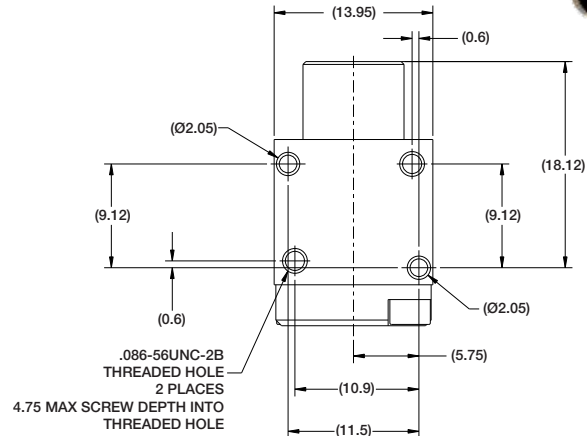
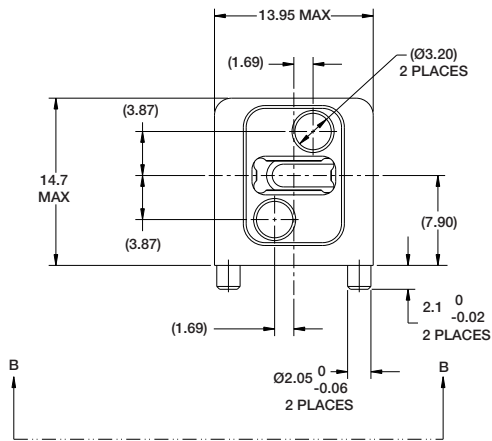

VIEW AT B

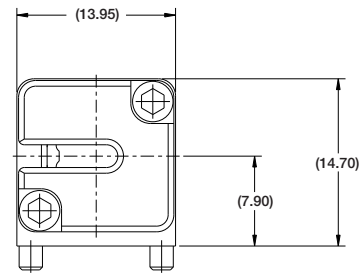
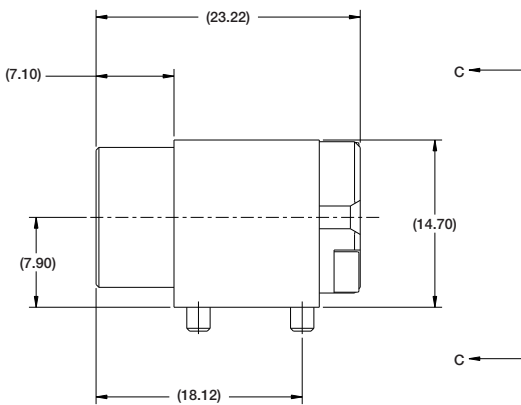

VIEW AT C

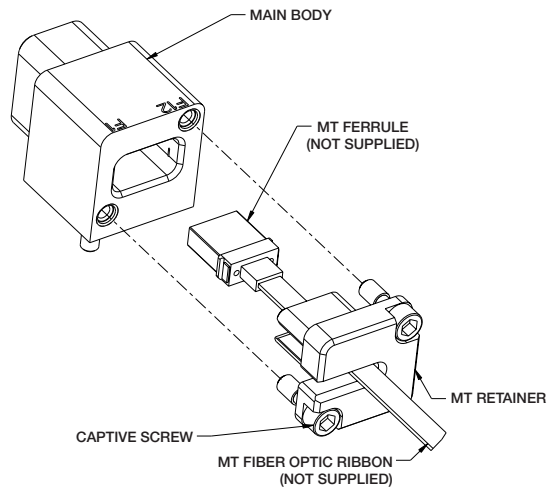
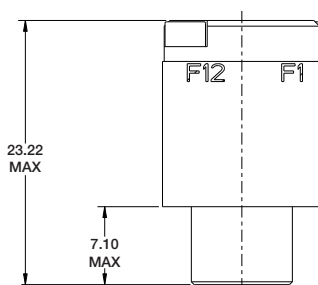

REAR EXPLODED ASSEMBLY VIEW

VITA 66.4

FIBER OPTIC VITA 66.4: Spring Loaded 1MT Backplane

PART NUMBER: 10-504639-010

(Dimensions in MM)

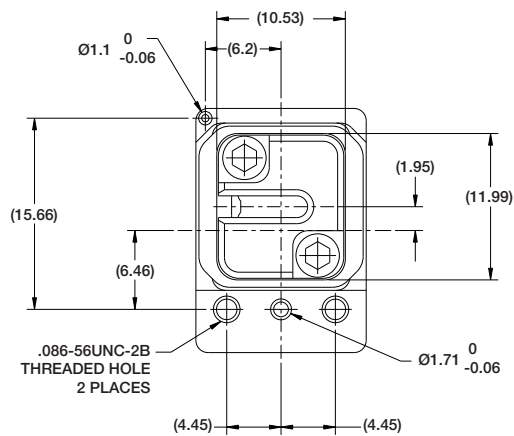
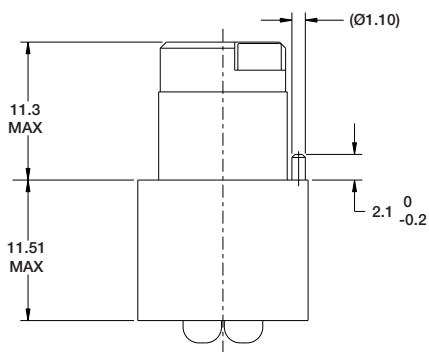
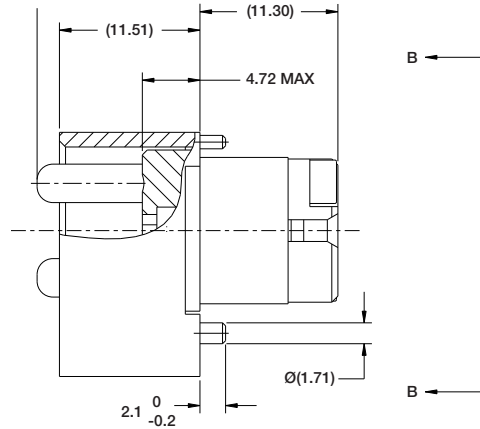
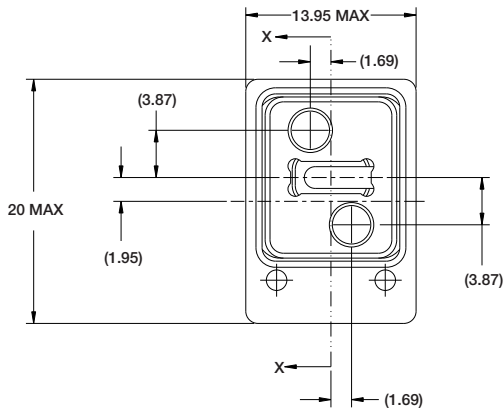

.086-56UNC-2B
THREADED HOLE
2 PLACES

VIEW AT B

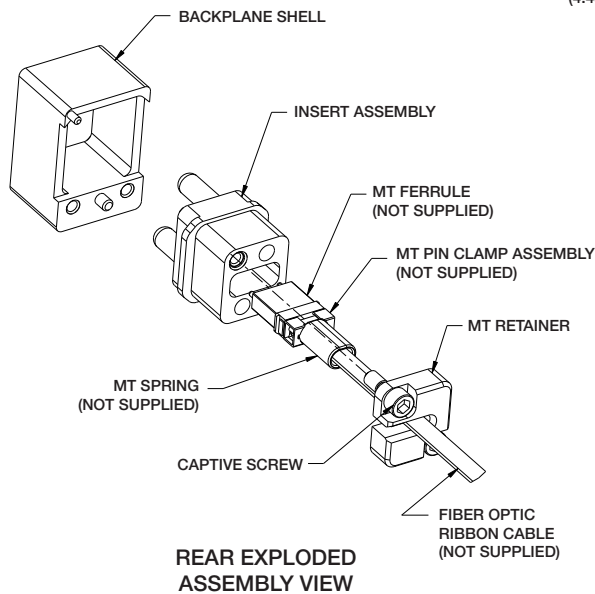

VITA 66.4

FIBER OPTIC VITA 66.4: Double Density 2MT Module

PART NUMBER: 10-504637-009

(Dimensions in MM)



VITA 66.4

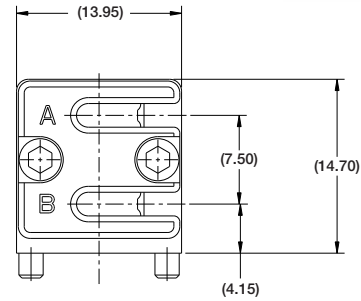
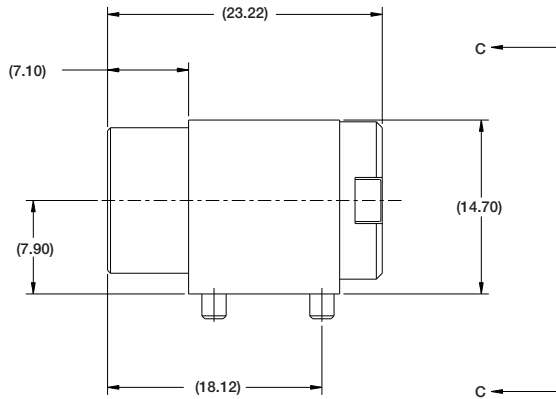

VIEW AT C

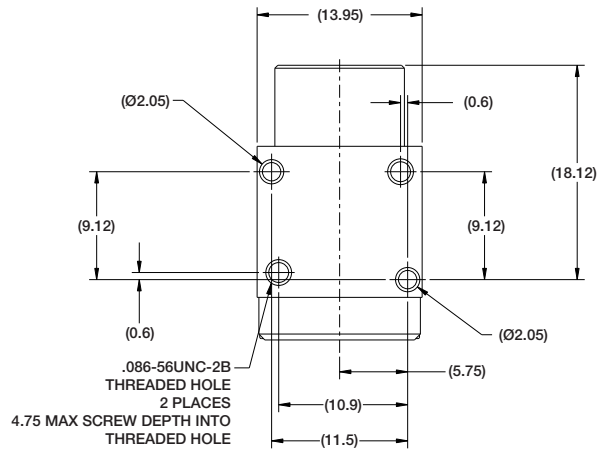
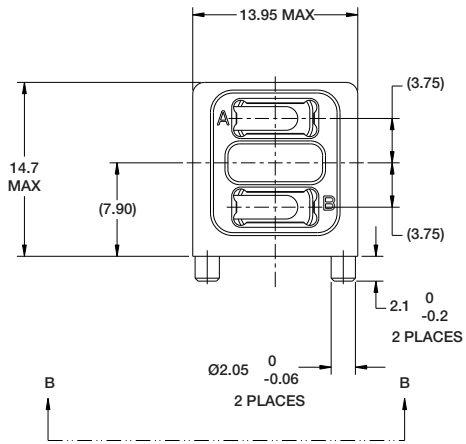

VIEW AT B

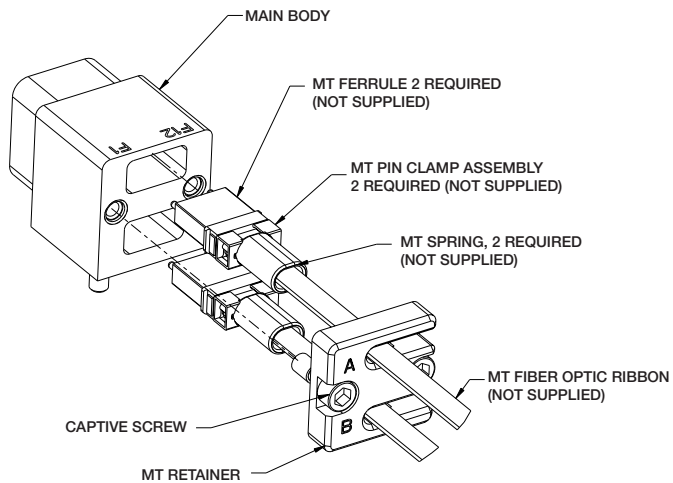
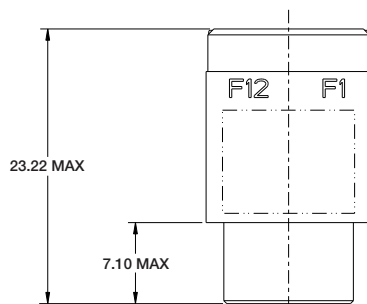

REAR EXPLODED ASSEMBLY VIEW

FIBER OPTIC VITA 66.4: Double Density 2MT Backplane

PART NUMBER: 10-504639-007

(Dimensions in MM)

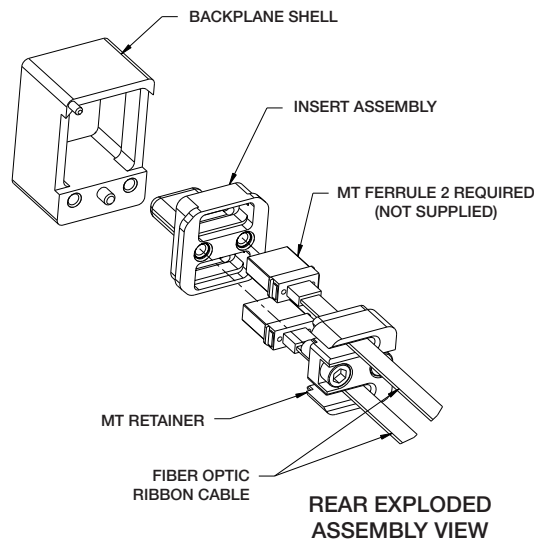
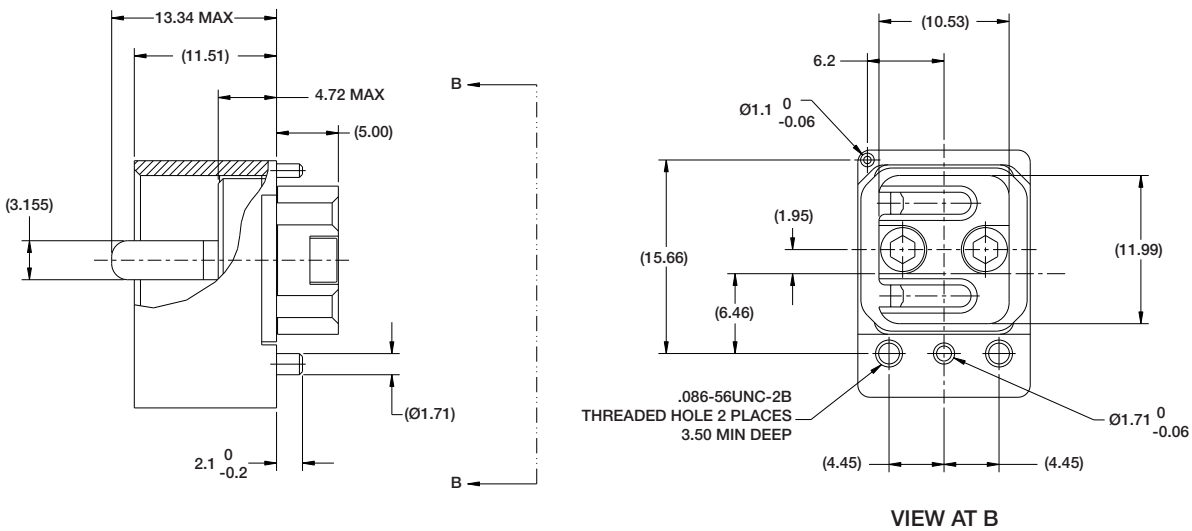
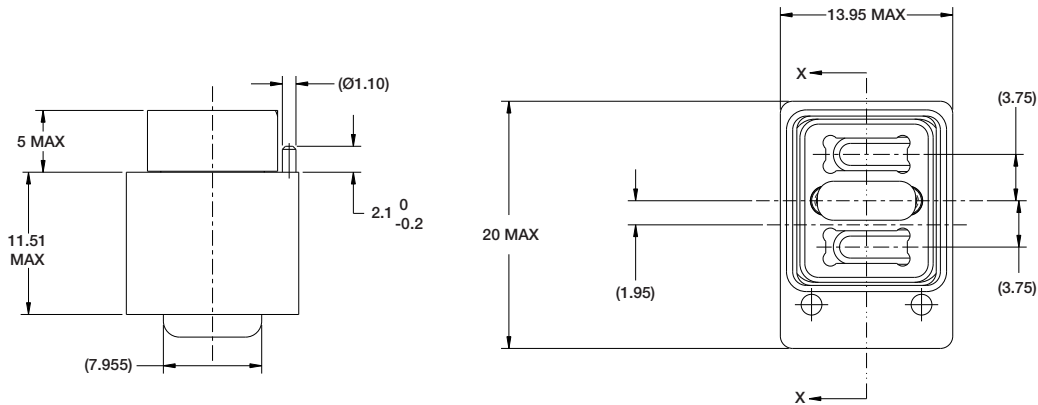

VITA 66.4

FIBER OPTIC VITA 66.4: Double Density 2MT Special Module

PART NUMBER: 10-504637-011

(Dimensions in MM)

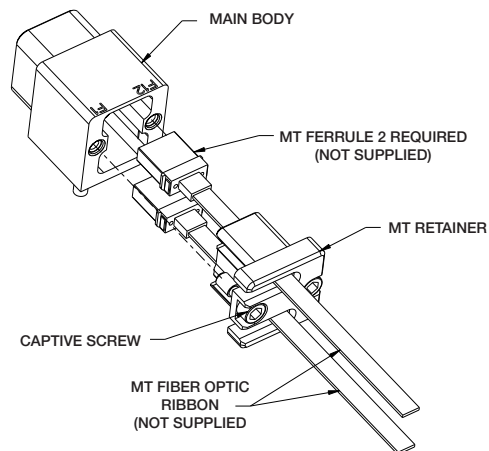
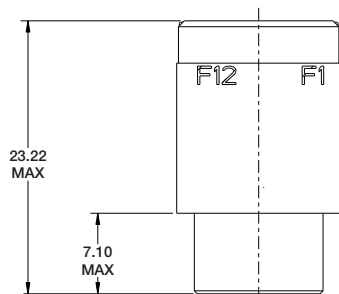
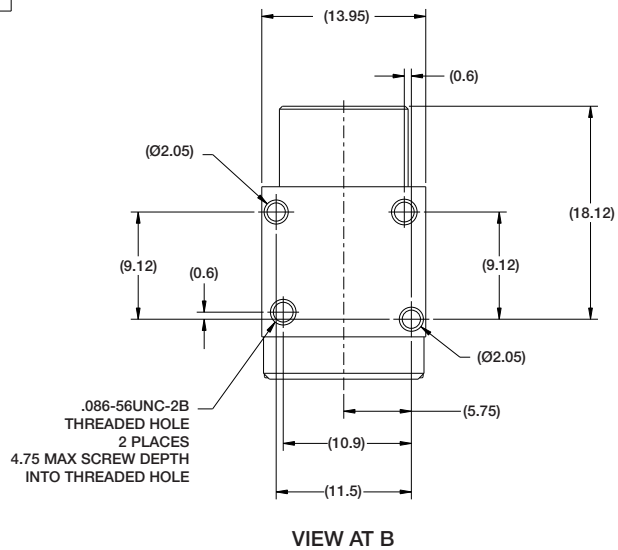
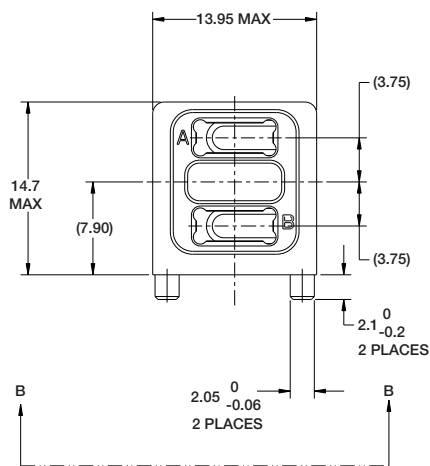
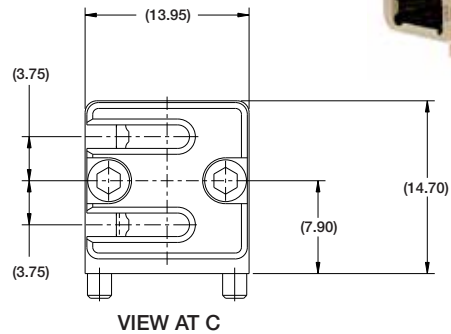
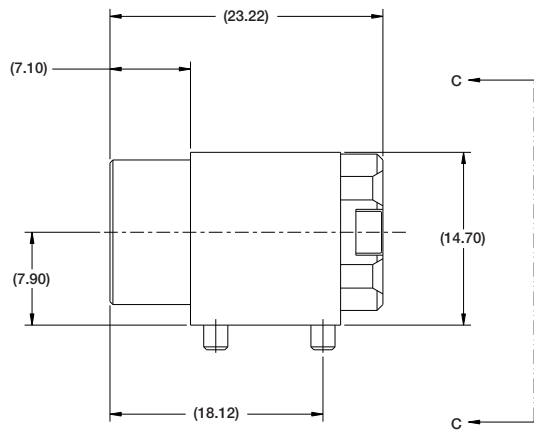

REAR EXPLODED ASSEMBLY VIEW

VITA 66.4

FIBER OPTIC VITA 66.4: Double Density Spring Loaded 2MT Backplane

PART NUMBER: 10-504639-009

(Dimensions in MM)

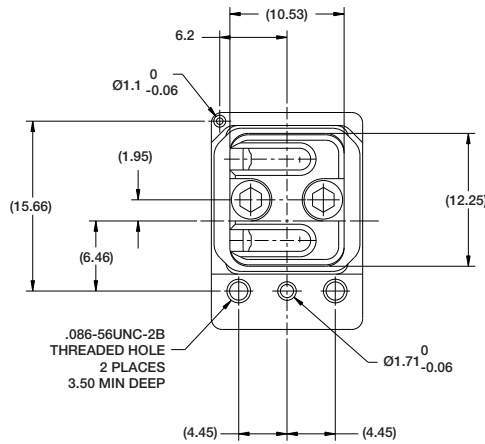
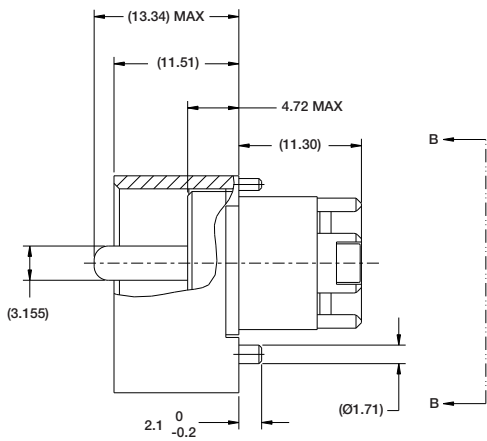
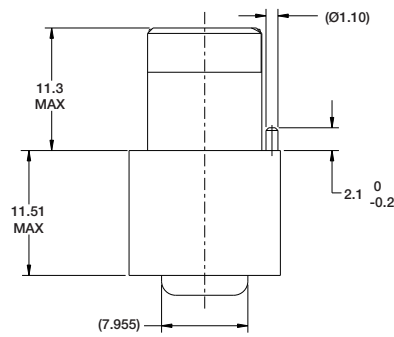
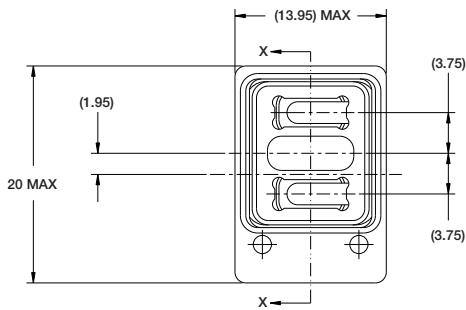

VIEW AT B

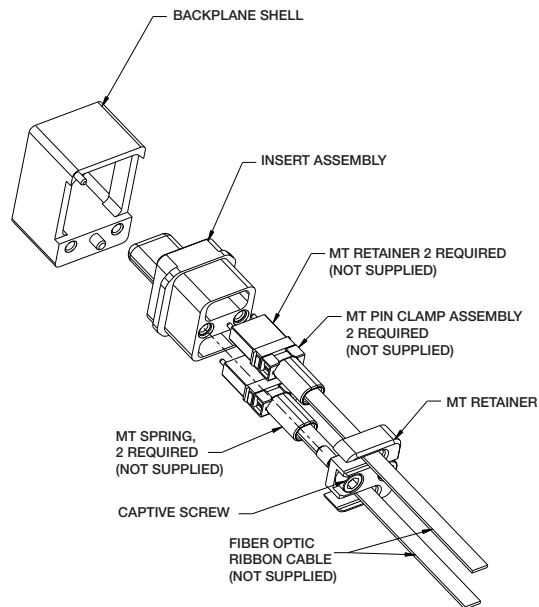

REAR EXPLODED ASSEMBLY VIEW

VITA 66.4

LIGHTCONEX VITA 66.5



Amphenol Aerospace's LightConex blind mate optical interconnect for 6U and 3U embedded VPX boards. LightConex integrates a 40Gbps optical transceiver, 120G optical transmitter, and 120G optical receiver into the module connector saving board space and eliminating cables.

The low profile backplane connector is a drop-in replacement for the standard VITA 66.4 connector. It includes springs to ensure a solid MT to MT connection under extreme shock and vibration.

The low profile module connector (6.5mm) mounts to the board via an LGA connector to facilitate optics as an option. It is offered as a 4-channel transceiver, a 12 channel transmitter or a 12-channel receiver. All module connectors operate at up to 10.3125 Gbps per lane from -40 to +85° C at ultra-low bit error rates of 10^{-15} . The module connector also includes equalizers and pre-emphasis to compensate trace impedance.

LightConex VITA 66.5 is designed for embedded computing applications in:



Single Processing Computer



Phase Array Radar



Single Board Computers

VITA 66.5

MODULE CONNECTOR FEATURES:

- Rugged: MIL STD 883
- Moisture resistant: Sealed
- Small (DxWxH): 14 x 23 x 6 mm
- Bandwidth: 10.3125 Gbps/ch
- Temperature: 40°C to +85°C
- Operating temperature range: -40°C to +85°C
- Reach: 300m, multi-mode
- BER: 10^{-15}
- Low power: 1.2W
- Data interface: CML
- Board Mount: LGA
- Configurations: 4TRx, 12Tx, 12Rx, 12TRx

BACKPLANE CONNECTOR FEATURES:

- VITA 66.4 drop in replacement
- Spring loaded MT
- Coarse and fine alignment
- Low Profile - 10mmF



QUALIFICATION TESTS

Vibration

- Sine Vibration Sweep - 10 minute sine vibration sweep of 5 g between 50 and 2000 Hz
- Shock - MIL-STD-1344A, Method 2004.1, Test Condition A (1/2 sine, 50 g in perpendicular axis, 80 g in other axes, 11 ms, 3 hits from both directions in each of 3 mutually perpendicular axes for a total of 18 hits)
- Random Vibration
 - Sample 1 - Test Condition V, letter D (0.1 G²/Hz max., 1.5 hours per axis)
 - Sample 2 - Step stress 0.125 G²/Hz for 15 minutes, 0.15 G²/Hz for 15 minutes, 0.175 G²/Hz for 15 minutes, and 0.2 G²/Hz for 45 minutes

Bench Handling

- The sample under test was raised on one edge using the opposite edge as a hinge 4 inches or 45 degrees (whichever is less). The other edges were tested the same.

Vibration over Temperature

- MIL-STD-1344A, Method 2005.1, Test Condition V, Letter D (0.1 G²/Hz max., 1.5 hours per axis, see Fig. 2 solid line), with simultaneous temperature exposure of -40 to 85°C.

Humidity

- Expose to humidity and temperature cycling per MIL-STD-1344A, Method 1002.2, Type III (240 hrs.). The sample shall be mated.

Salt Fog

- Salt Fog with SO₂ per ASTM G85 (Annex A4, Cycle A4.4.4.1). The test sample shall be exposed in the mated condition in a sheet metal container.

Sand and Dust

- MIL-STD-810F, Method 510.4, Procedure I (Blowing Dust, particle size < 150 μm, velocity 1750 ft/min). The sample will be mated. The dust test on these two samples will be followed by a Blowing Sand test, also per MIL-STD-810F, Method 510.4, Procedure II (Blowing Sand, particle size > 150 μm but < 850 μm, velocity 5700 ft/min).

Durability

- 500 mate/un-mate cycles. VI, RNT shall be performed after 500 mate/un-mate cycles.

LIGHTCONEX 10-743008-00X

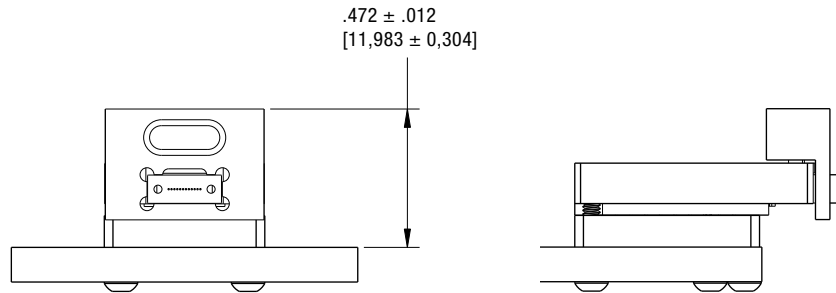

Part Number	Reflex Optical Active Device P/N (POS 5)	Reflex Optical Active Device Description
10-743008-003*	NONE	NONE
10-743008-004	10-743017-004	4TX/4RX, Transceiver, 10.3125-Gbps/CH, SENS: -12.0dBm**, -40°C to +85°C
10-743008-005	10-743017-005	12TX, Transmitter, 10.3125-Gbps/CH, -40°C to +85°C
10-743008-006	10-743017-006	12RX, Receiver, 10.3125-Gbps/CH, SENS: -12.0dBm**, -40°C to +85°C

* 10-743008-003 includes all the components to connect an optical device to a PCB without the optical device itself.

** If operating at 12.5 Gbps the receiver sensitivity will be -4dBm

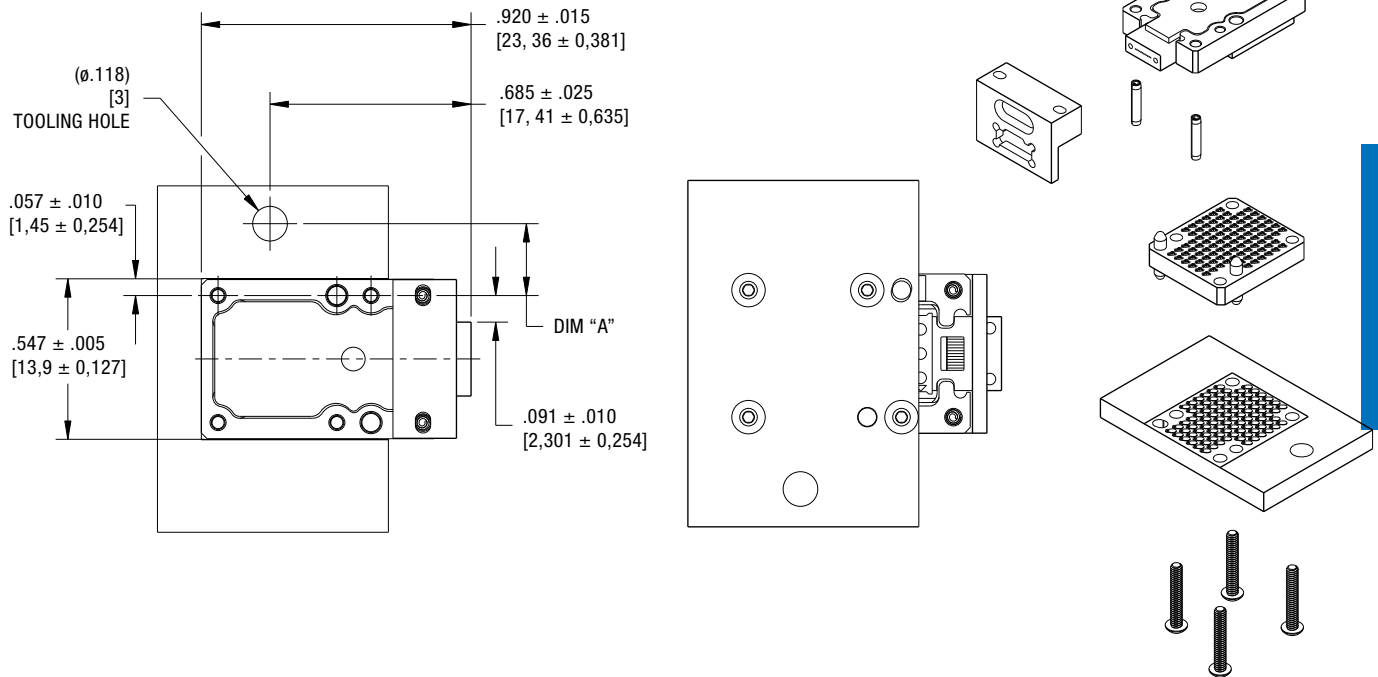

LIGHTCONEX 10-743007-002

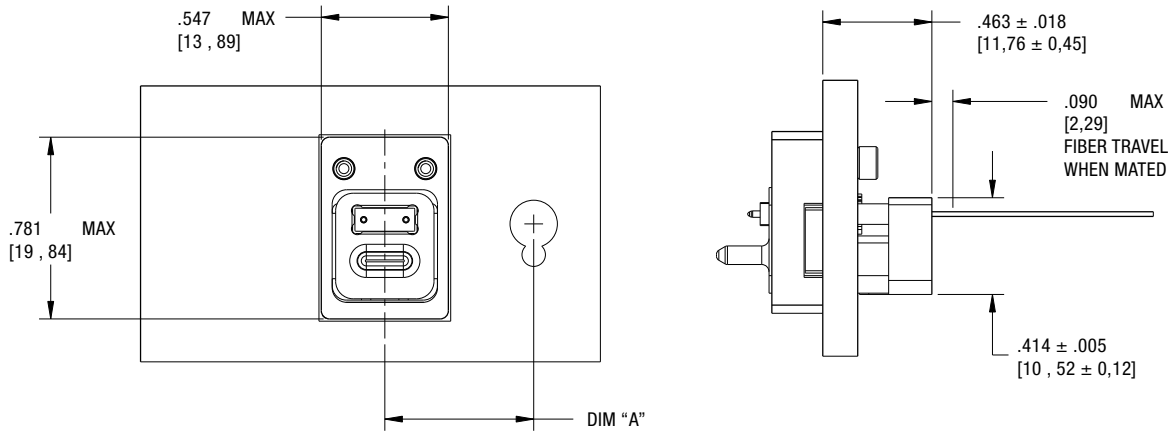

Part Number	Optical Active Device Description
10-743007-002	Passive Backplane Connector

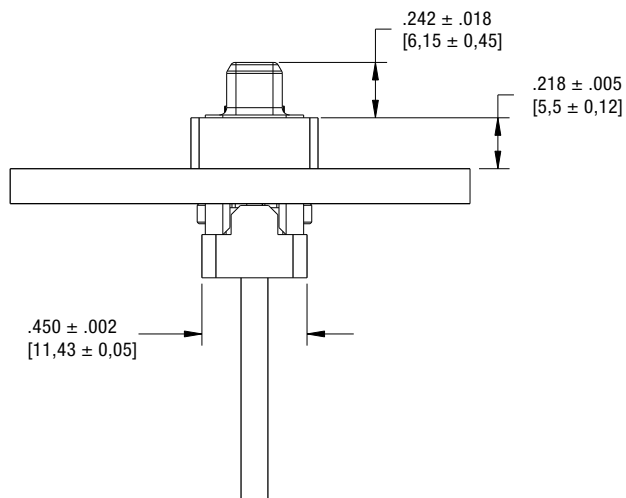
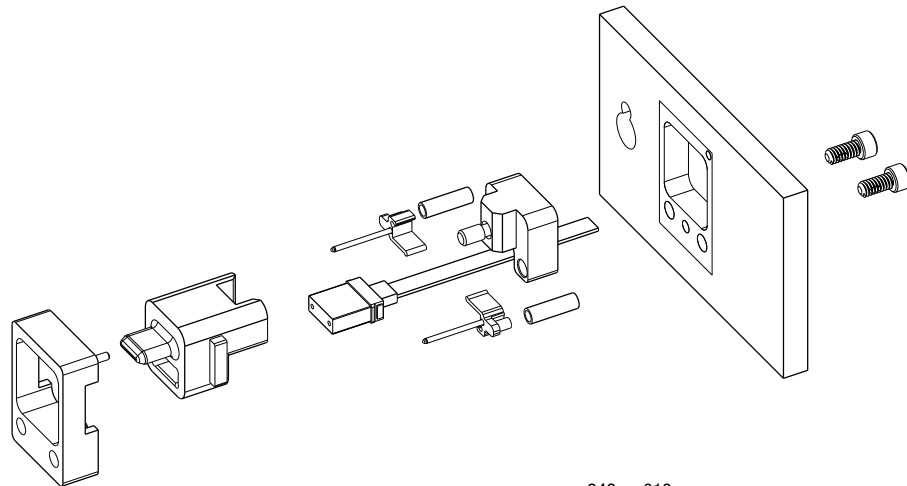

VITA 66.5

HIGH DENSITY VITA 67 FOR EMBEDDED COMPUTING

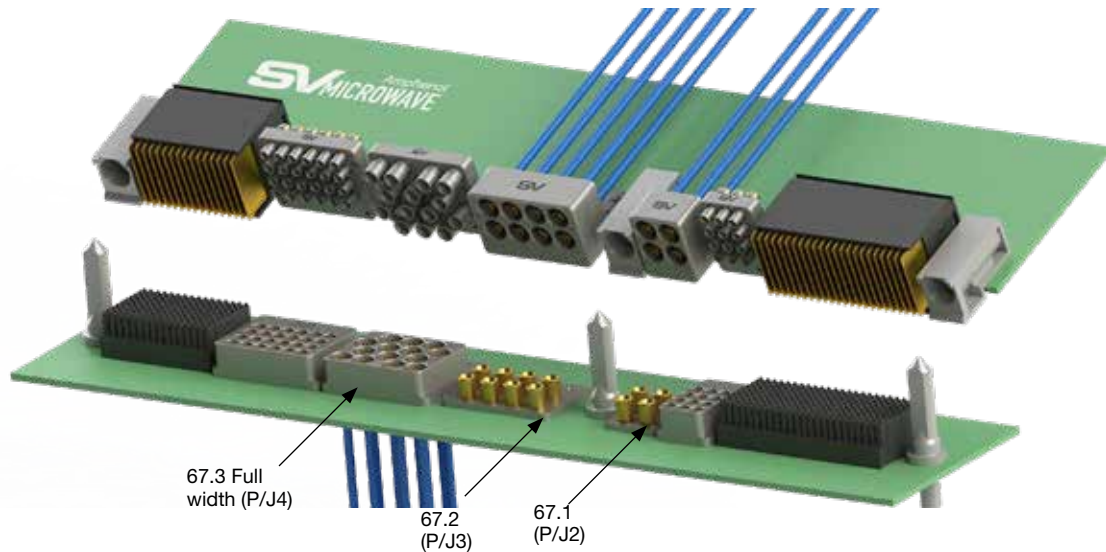

Amphenol's VITA 67 complete line of coaxial interconnects is a high density and high-performance RF addition to the VPX Platform. The floating SMPM and SMPS coaxial contacts ensure excellent RF performance in any mating condition. These parts are also designed for side-by-side implementation with VITA 46 hardware and can be cabled to .085" and smaller diameter coaxial cable types.

High Frequency VITA 67 RF products are primarily designed for embedding computing applications in the defense and commercial markets.



VITA 67

HIGH DENSITY SMPS VITA 67 OVERVIEW

FEATURES & BENEFITS:

- Customizable RF contact locations within module
- Coaxial interface standard for daughtercard to backplane connectors
- Designed for side-by-side implementation with other VITA connector standards
- Floating SMPM & SMPS coaxial pins ensure excellent RF performance in any mating condition
- Unique SV connector retention mechanism offers significant ease of assembly/disassembly



APPLICATIONS:

- Robust and rugged high speed cabled solution
- High-reliability, high-density for aerospace & defense applications
- SIGINT, EWR, ground base station & communication systems, avionics, radar systems
- Air Transport Racks (ATRs) without Rear Transition Modules (RTMs) or limited speed through RTM

PRODUCT RANGE:

- VITA 67.1/2: SMPM contacts, cable assemblies, modules and tools
- VITA 67.3: SMPM & SMPS contacts, cable assemblies, adapters, modules and tools

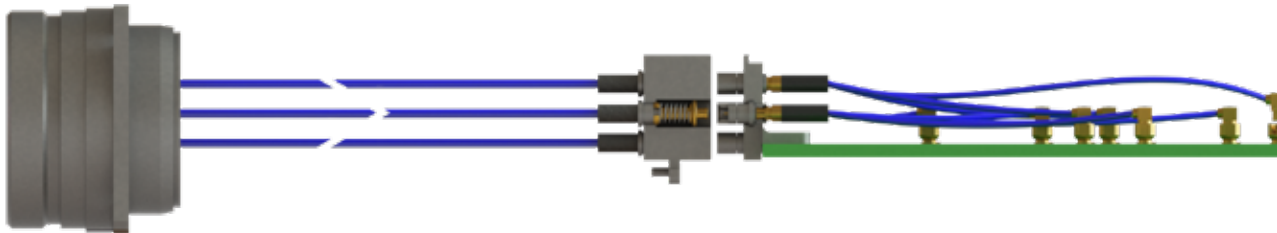

VITA 67

SMPM VITA 67.1 PLUG-IN MODULE

PART NUMBER: SF9321-60015

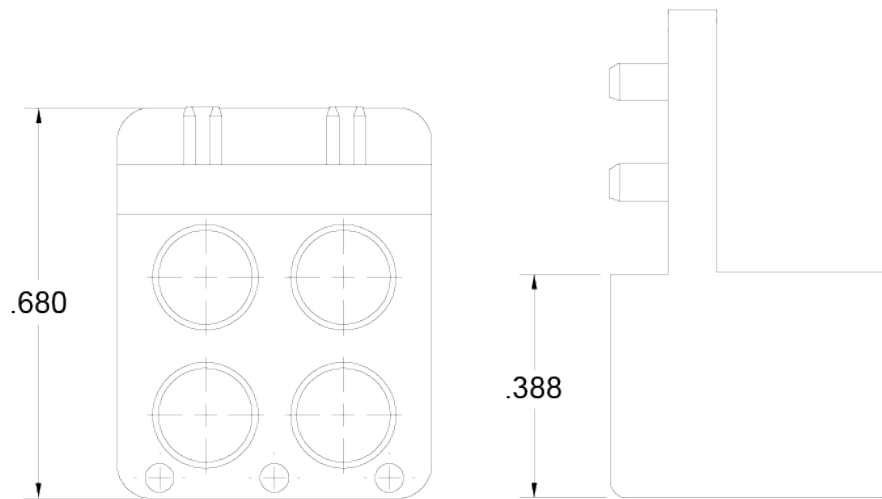

SMPM VITA 67.1 BACKPLANE MODULE

PART NUMBER: SF1132-6037

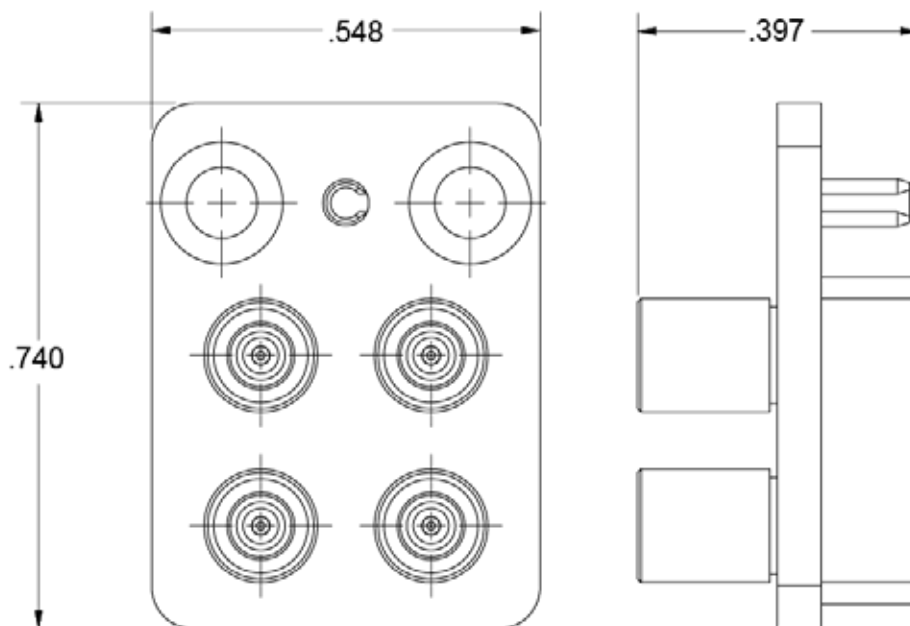

VITA 67

SMPM VITA 67.2 PLUG-IN MODULE

PART NUMBER: SF9321-60013

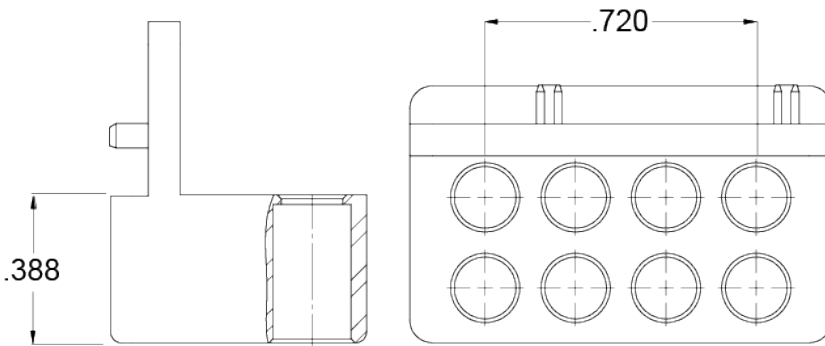

SMPM VITA 67.2 BACKPLANE MODULE

PART NUMBER: SF1132-6036

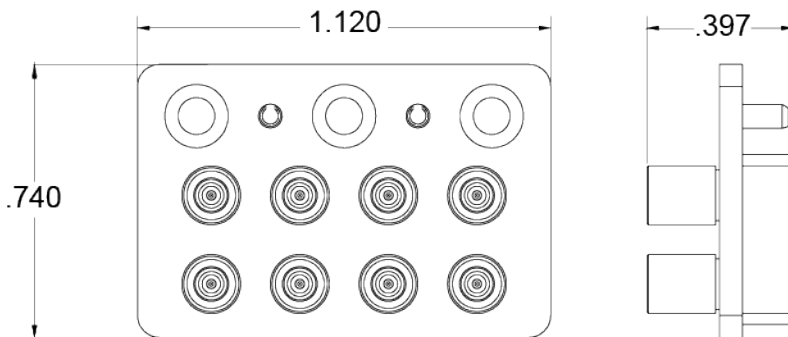

VITA 67

SMPM FEMALE VITA 67.1/2 PLUG-IN CONTACT FOR .047 CABLE

PART NUMBER: 3221-40019

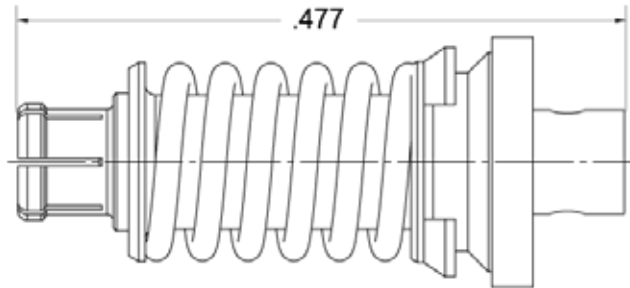

SMPM FEMALE VITA 67.1/2 PLUG-IN CONTACT FOR Ø.086 CABLE

PART NUMBER: 3221-40022

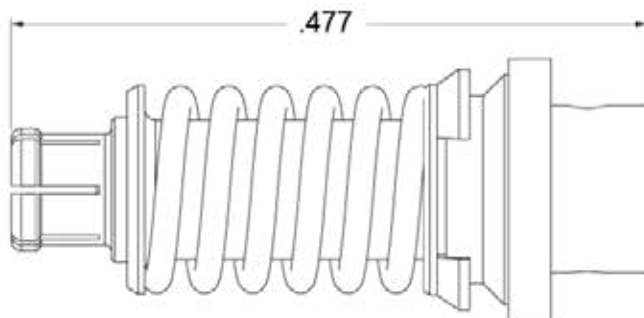

SMPM FEMALE VITA 67.1/67.2 TO SMA MALE CABLE ASSEMBLY FOR .047 CABLE

OAL 6" 7032-6728-060, OAL 12" 7032-6728-120

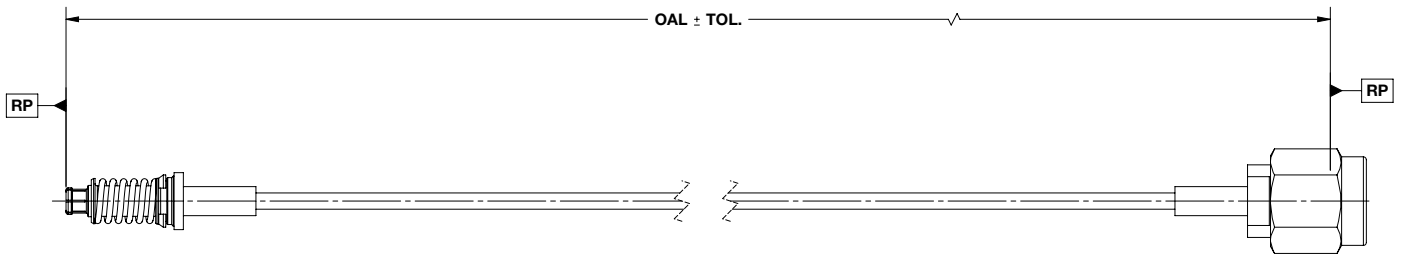

SMPM FEMALE VITA 67.1/67.2 TO SMA MALE CABLE ASSEMBLY FOR .085 CABLE

OAL 6" 7032-6729-060, OAL 12" 7032-6729-120

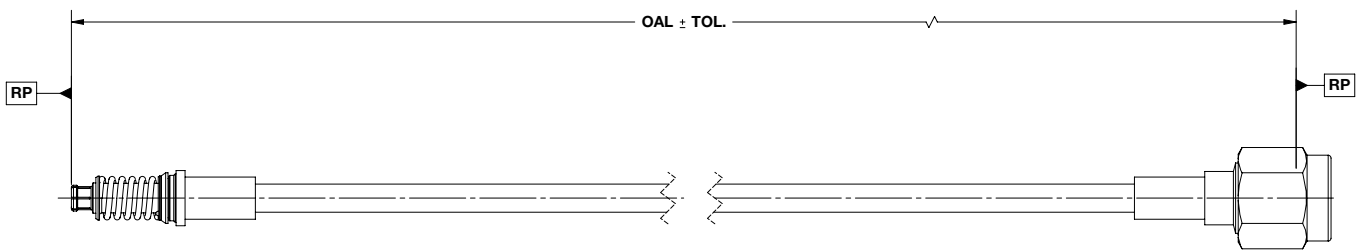

SMPM VITA 67.3C 10-PORT PLUG-IN MODULE

PART NUMBER: 9311-60220

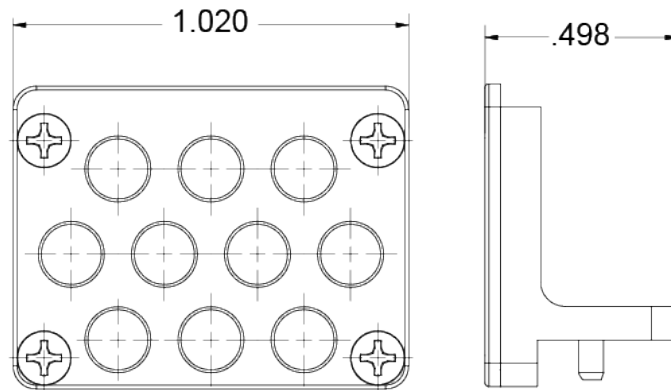

SMPM VITA 67.3C 10-PORT BACKPLANE MODULE

PART NUMBER: SF9321-60059

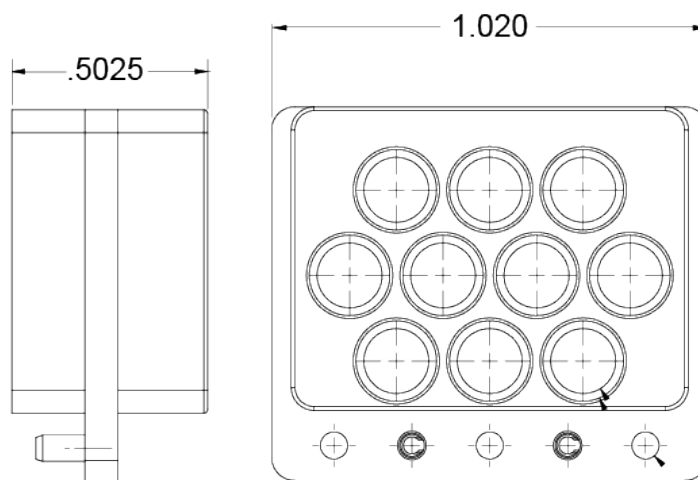

VITA 67

SMPM VITA 67.3 SOSA 14 PORT PLUG-IN MODULE

PART NUMBER: 9311-60221

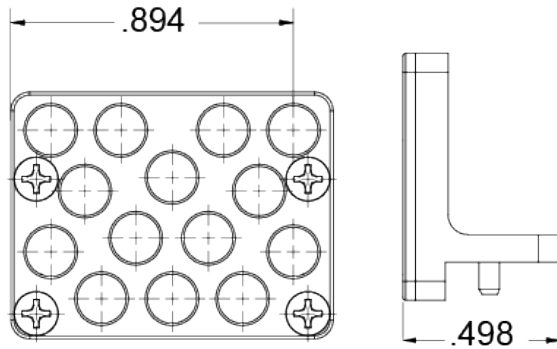

SMPM VITA 67.3 SOSA 14 PORT BACKPLANE MODULE

PART NUMBER: SF9321-60086

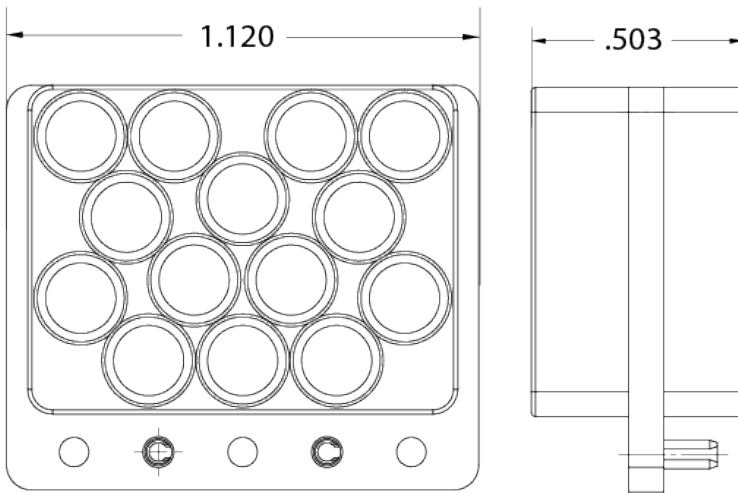

SMPM MALE TO SMPM VITA 67.3 MALE PLUG-IN ADAPTER

PART NUMBER: 1132-6116

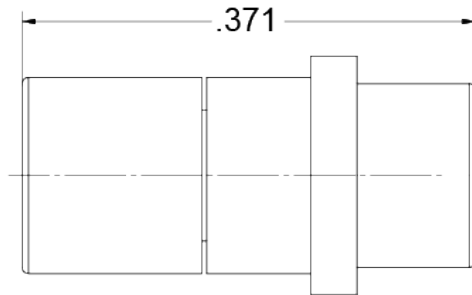

SMPM FEMALE TO FEMALE BULLET (OAL 0.211")

PART NUMBER: 3290-4002

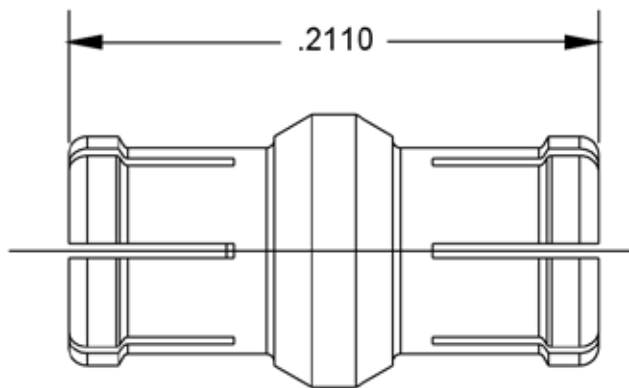

SMPM MALE EDGE LAUNCH CONNECTOR, SB

PART NUMBER: 3211-60035

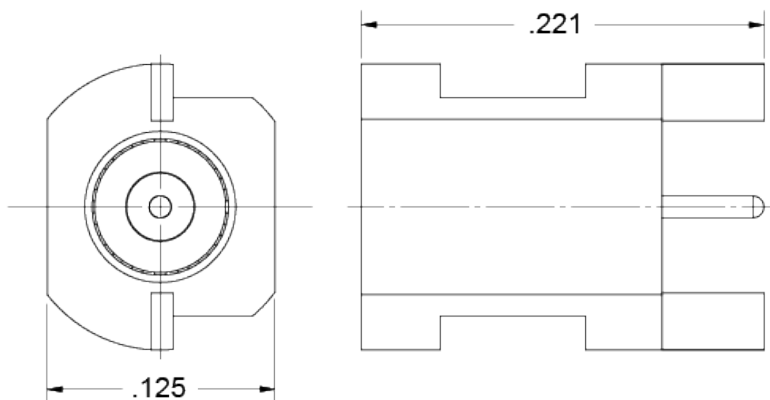

SMPM FEMALE VITA 67.3 BACKPLANE CONTACT FOR .047 CABLE

PART NUMBER: 3221-40071

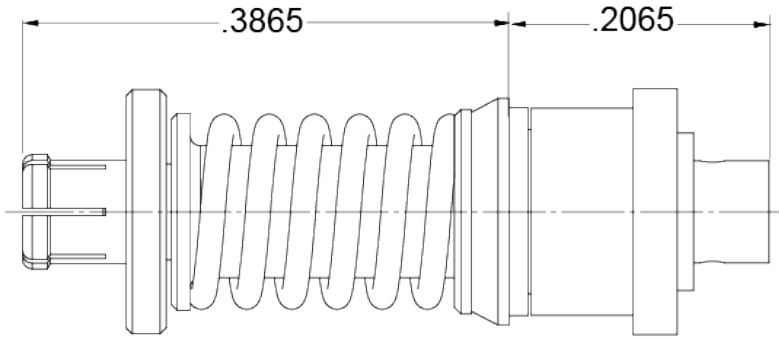

SMPM FEMALE VITA 67.3 BACKPLANE CONTACT FOR .086 CABLE

PART NUMBER: 3221-40066

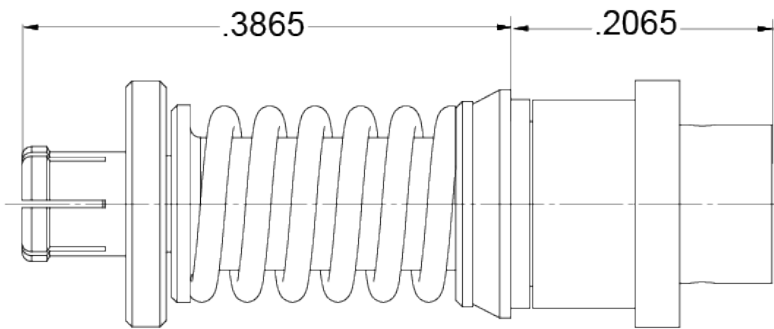

VITA 67

SMPM VITA 67.3 BACKPLANE CONTACT FOR .047 CABLE

PART NUMBER: 3821-40023

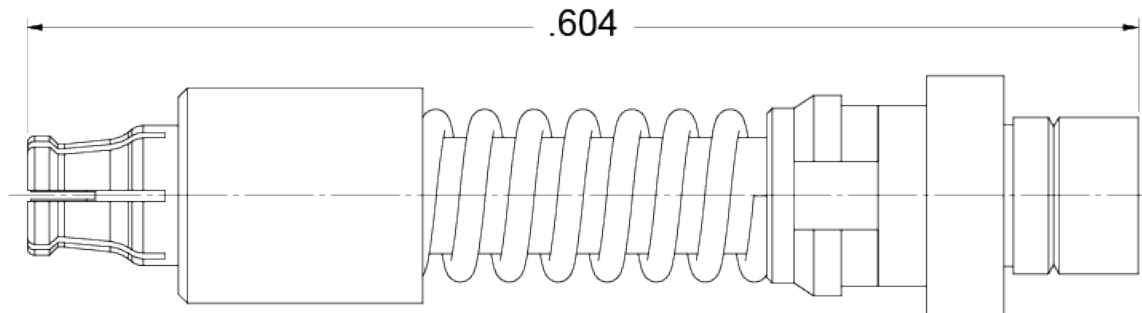

SMPM VITA 67.3 BACKPLANE CONTACT FOR .085 CABLE

PART NUMBER: 3821-40024

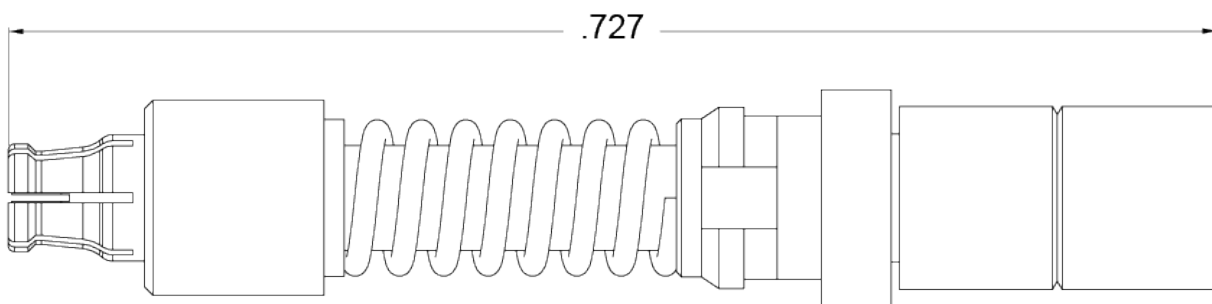

SMPS VITA 67.3 12 PORT PLUG-IN MODULE D

PART NUMBER: SF9311-60166

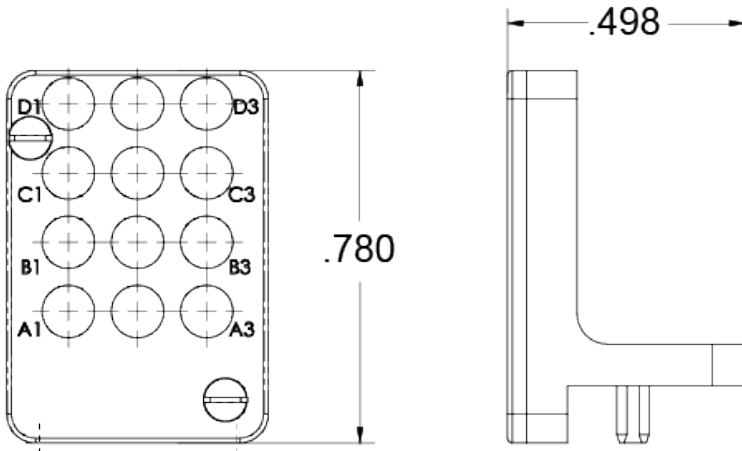

SMPS VITA 67.3 19 PORT PLUG-IN MODULE C

PART NUMBER: SF9311-60171

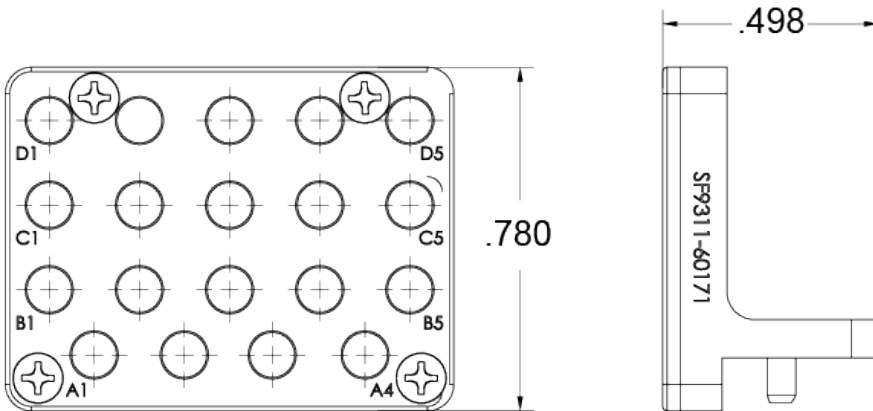

VITA 67

SMPS VITA 67.3 12 PORT BACKPLANE MODULE D

PART NUMBER: SF9321-60084

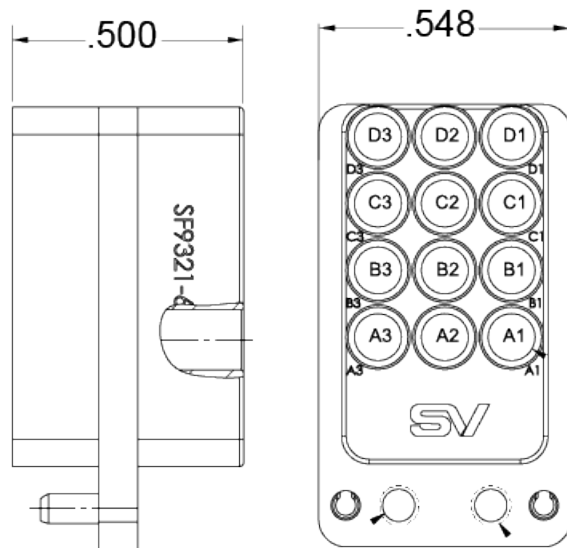

SMPS VITA 67.3 19 PORT BACKPLANE MODULE D

PART NUMBER: SF9321-60093

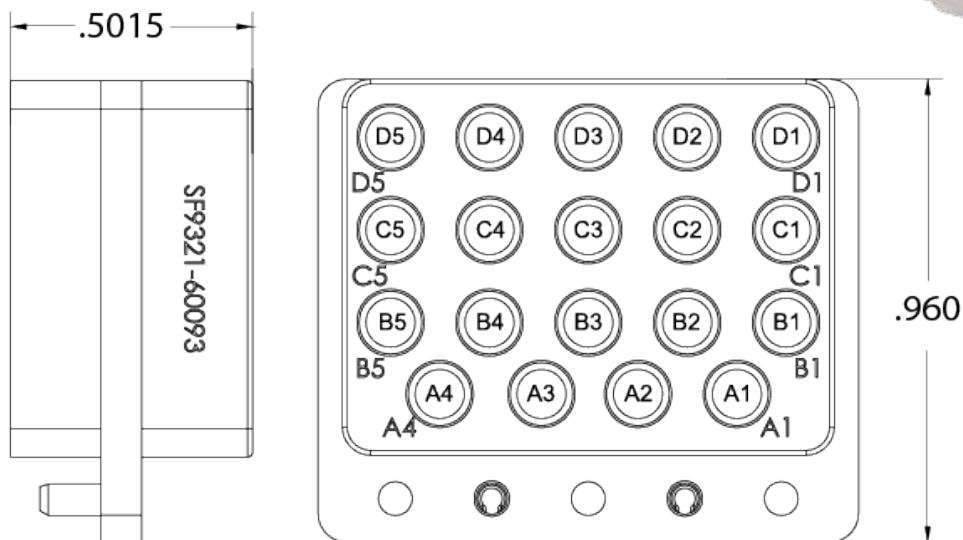

VITA 67

VITA 67 CONTACT REMOVAL

FEMALE CONTACT REMOVAL

Amphenol SV Microwave has a one step process for female contact removal. This unique connector retention mechanism offers significant ease of assembly/disassembly, using the SMPM VITA 67.3 (500-32-015), SMPS VITA 67.3 (500-38-006), and SMPM VITA 67.1/2 (500-32-022) removal tools.

Gently insert the tool in the contact cavity and push on the plunger to take out the contact.



500-32-015

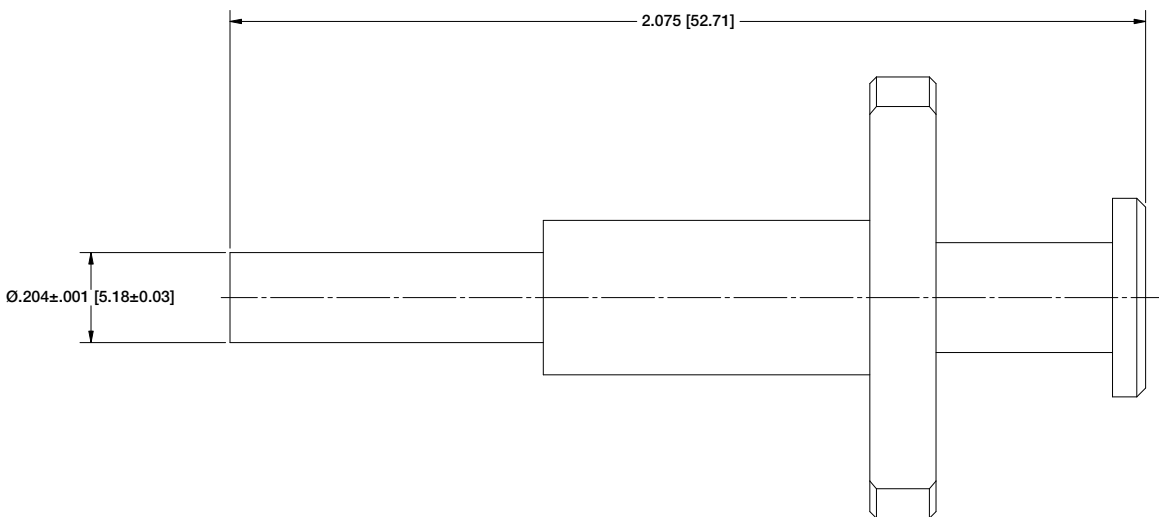
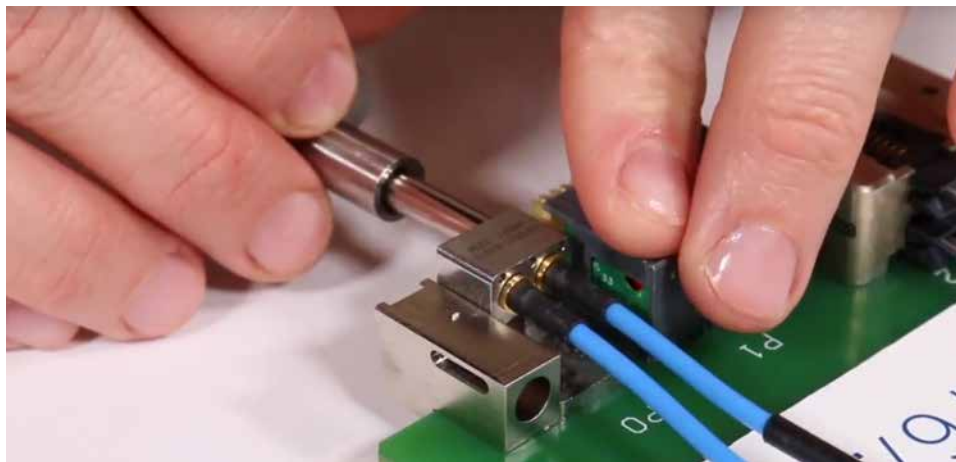

VITA 67 CABLE INSTALLATION

The Amphenol VITA 67 range is designed for simple end user assembly procedures.

SMPS VITA 67.3 cable installation tool (500-38-008)



VISUAL AID

The illustrations below shows the typical assembly of a VITA 67 embedded system.

PLUG-IN CARD EXPLODED VIEW, CATALOG SMPM PCB LAUNCH AND BULLET SHOWN ON CARRIER CARD

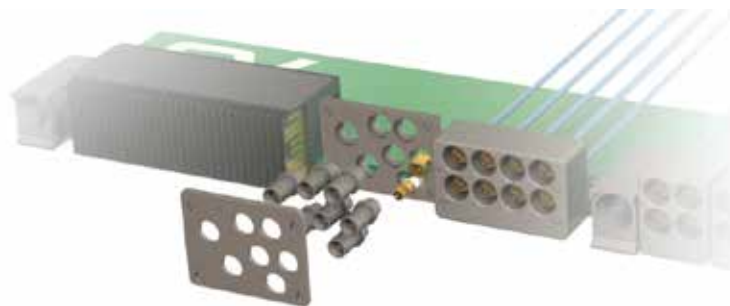

BACKPLANE MODULE C EXPLODED VIEW WITH Ø .086 SMPM CONTACTS

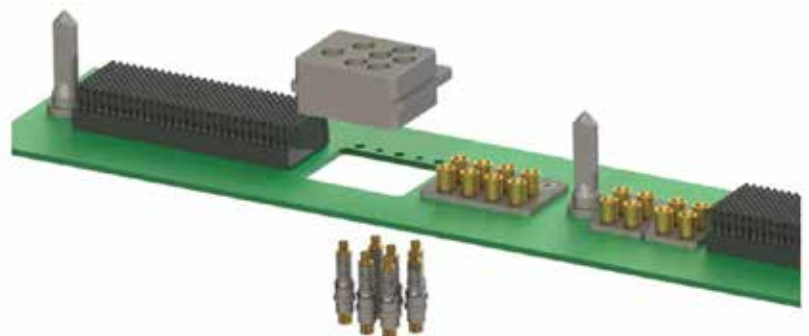

SMPM CONTACTS ASSEMBLY PROCESS

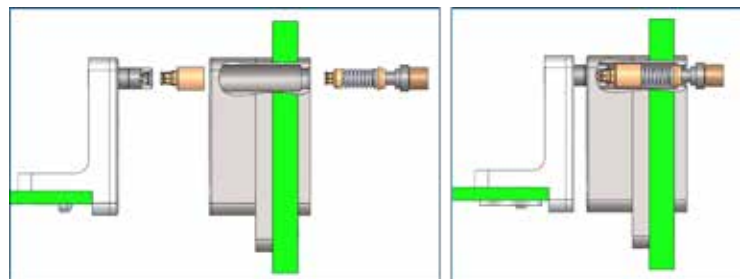

VITA 67

CONTACT INFORMATION

+US territory

R-VPX (VITA 46), VITA 48.4, 66.1 & 66.4 – Amphenol Aerospace

Catalin Brandas, Product Manager

cbrandas@amphenol-ao.com

Office: +1-607-563-5129

Cell: +1-607-643-5071

LIGHTCONEX – Amphenol Aerospace

Joe Rothrock

jrothrock@amphenol-ao.com

Office: +1 (607) 563-5062

VITA 67 – Amphenol SV Microwave

Hardik Parikh, Product Manager

hparikh@svmicro.com

Office: +1-203-947-6512

+Europe

Amphenol Socapex

Guillaume Montessuit, Product Manager

guillaume.montessuit@amphenol-socapex.fr

Office : +33 4 50 90 49 33

Cell: +33 6 98 89 94 67

CHECK OUT OUR ONLINE VIDEOS ABOUT VITA PRODUCTS TO LEARN MORE



See more on Amphenol MAO YouTube Channel