

DUAL CHANNEL 100G ETHERNET COPPER TO FIBER CONVERTER

Two MT Ferrule to VITA 46 VPX Connectors

PDS - 525

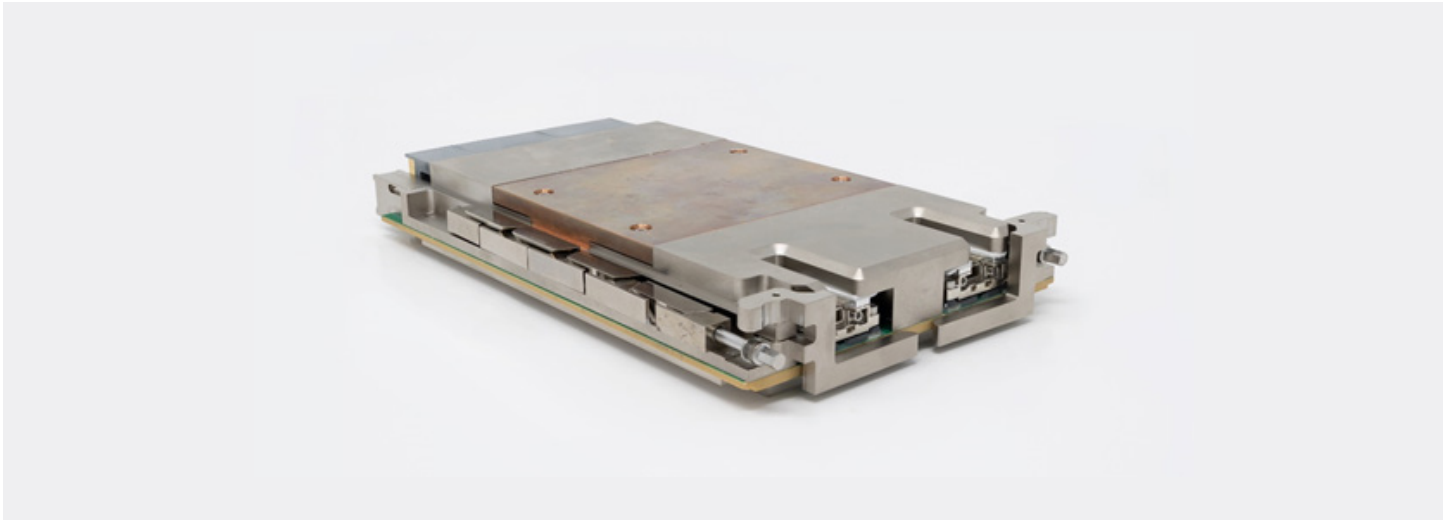

DESCRIPTION

This Amphenol converter will transform your high-speed needs to a new level. We have taken two existing high-speed technologies and combined them into a media converter. Now you can transfer high speed data seamlessly from copper to fiber and from fiber to copper.

The following product utilizes the proven technology of the LEAP On-Board Transceiver with MT ferrules and the high-speed R-VPX connector with optimal signal integrity performance to create a media converter that is capable of two channels of 100GBASE-SR4 or eight channels of 1G, 10G, or 25G Ethernet fiber to copper conversion.

FEATURES

- Converts eight channels of 1G/10G/25BASE-SR to 40G/10G/100GBASE-KR to 40G100BASE-KR4.
- Perfect for routing multiple fiber optic Ethernet connections into systems
- Compliant with IEEE 802.3an Ethernet Standards and specifications and VITA 46 and VITA 47 standards
- Intermateable with existing and legacy VITA 46 connectors and backplanes
- Media conversion at the connector reduces system complexity and cost
- -40°F(-40°C) to 185°F(+85°C)
- Full support for KR and KR4 link training and auto-negotiation

POWER SPECIFICATIONS

- Standard 5 and 12V according to OpenVPX standards
- Low power consumption

INTERFACE

- VITA 46 3U VPX available in conduction and air cooled configuration for rugged environment and harsh vibration profiles
- Industry standard 24F MT receptacles
- Interfaces for power, diagnostics, and others
- No need for internal subsystem fiber harnesses, interconnect, or transceivers

MECHANICAL SPECIFICATIONS

CF-020400-584

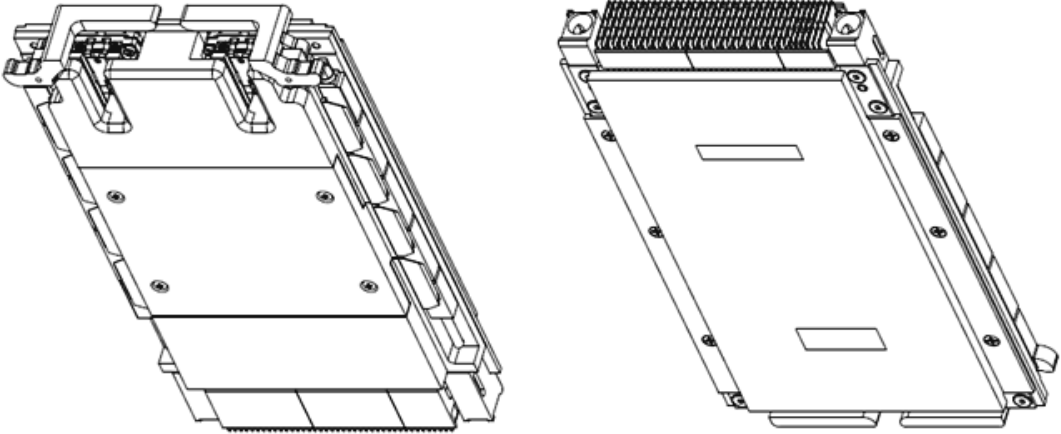
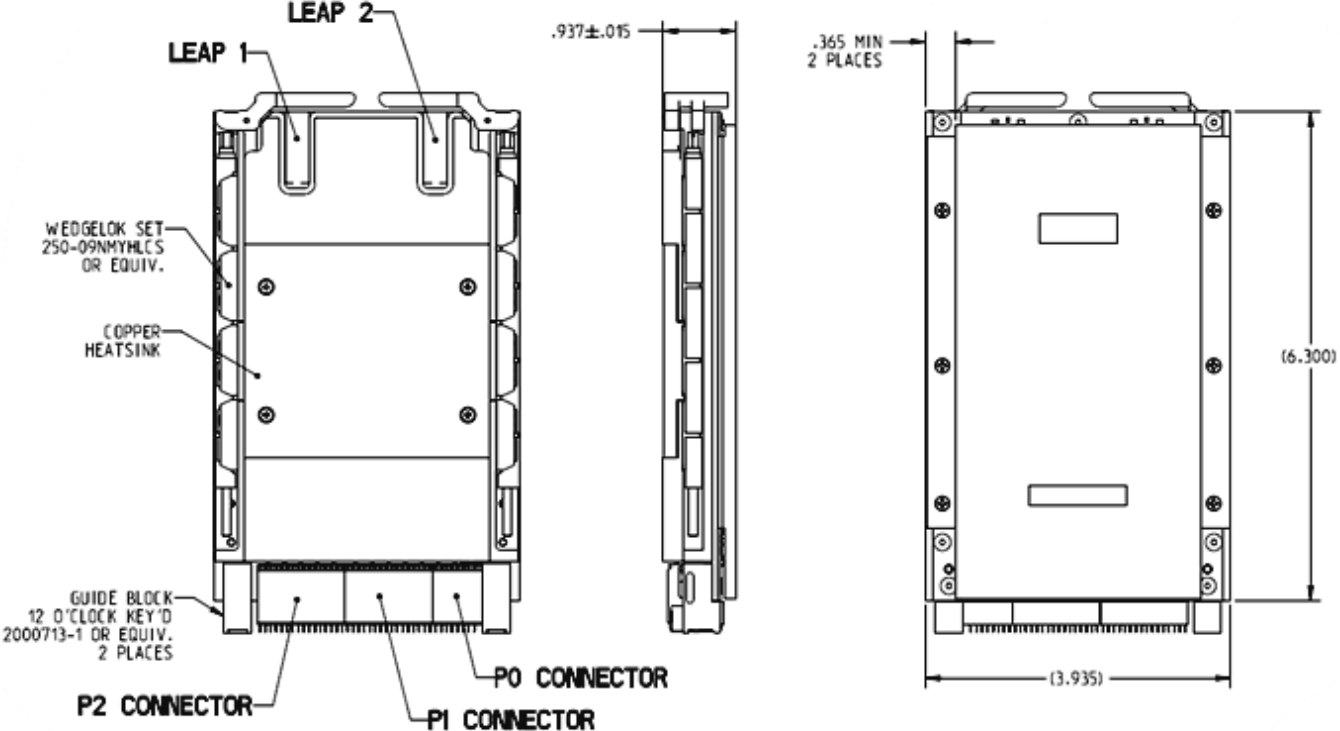

LEAP 1 I/O CHART			
ID	SIGNAL	ID	SIGNAL
T1	P33_25G-SR_TX	R1	P33_25G-SR_RX
T2	P34_25G-SR_TX	R2	P34_25G-SR_RX
T3	P35_25G-SR_TX	R3	P35_25G-SR_RX
T4	P36_25G-SR_TX	R4	P36_25G-SR_RX
T5	P37_25G-SR_TX	R5	P37_25G-SR_RX
T6	P38_25G-SR_TX	R6	P38_25G-SR_RX
T7	P39_25G-SR_TX	R7	P39_25G-SR_RX
T8	P40_25G-SR_TX	R8	P40_25G-SR_RX
T9	P41_25G-SR_TX	R9	P41_25G-SR_RX
T10	P42_25G-SR_TX	R10	P42_25G-SR_RX
T11	P43_25G-SR_TX	R11	P43_25G-SR_RX
T12	P44_25G-SR_TX	R12	P44_25G-SR_RX

LEAP 2 I/O CHART			
ID	SIGNAL	ID	SIGNAL
T1	P45_25G-SR_TX	R1	P45_25G-SR_RX
T2	P46_25G-SR_TX	R2	P46_25G-SR_RX
T3	P47_25G-SR_TX	R3	P47_25G-SR_RX
T4	P48_25G-SR_TX	R4	P48_25G-SR_RX
T5	P49_25G-SR_TX	R5	P49_25G-SR_RX
T6	P50_25G-SR_TX	R6	P50_25G-SR_RX
T7	P51_25G-SR_TX	R7	P51_25G-SR_RX
T8	P52_25G-SR_TX	R8	P52_25G-SR_RX
T9	P53_25G-SR_TX	R9	P53_25G-SR_RX
T10	P54_25G-SR_TX	R10	P54_25G-SR_RX
T11	P55_25G-SR_TX	R11	P55_25G-SR_RX
T12	P56_25G-SR_TX	R12	P56_25G-SR_RX

P1 I/O CHART							
	G	F	E	D	C	B	A
1	SWITCH_USB_D+	GND	P1_25G-KR_TX#	P1_25G-KR_TX	GND	P1_25G-KR_RX#	P1_25G-KR_RX
2	GND	P2_25G-KR_TX#	P2_25G-KR_TX	GND	P2_25G-KR_RX#	P2_25G-KR_RX	GND
3	SWITCH_USB_D-	GND	P3_25G-KR_TX#	P3_25G-KR_TX	GND	P3_25G-KR_RX#	P3_25G-KR_RX
4	GND	P4_25G-KR_TX#	P4_25G-KR_TX	GND	P4_25G-KR_RX#	P4_25G-KR_RX	GND
5	SWITCH_XSMI_MDIO	GND	P5_25G-KR_TX#	P5_25G-KR_TX	GND	P5_25G-KR_RX#	P5_25G-KR_RX
6	GND	P6_25G-KR_TX#	P6_25G-KR_TX	GND	P6_25G-KR_RX#	P6_25G-KR_RX	GND
7	SWITCH_XSMI_MDC	GND	P7_25G-KR_TX#	P7_25G-KR_TX	GND	P7_25G-KR_RX#	P7_25G-KR_RX
8	GND	P8_25G-KR_TX#	P8_25G-KR_TX	GND	P8_25G-KR_RX#	P8_25G-KR_RX	GND
9	SWITCH_I2C_SDA	GND	P9_25G-KR_TX#	P9_25G-KR_TX	GND	P9_25G-KR_RX#	P9_25G-KR_RX
10	GND	P10_25G-KR_TX#	P10_25G-KR_TX	GND	P10_25G-KR_RX#	P10_25G-KR_RX	GND
11	SWITCH_I2C_SCL	GND	P11_25G-KR_TX#	P11_25G-KR_TX	GND	P11_25G-KR_RX#	P11_25G-KR_RX
12	GND	P12_25G-KR_TX#	P12_25G-KR_TX	GND	P12_25G-KR_RX#	P12_25G-KR_RX	GND
13	CPU_RS232_TXD	GND	P13_25G-KR_TX#	P13_25G-KR_TX	GND	P13_25G-KR_RX#	P13_25G-KR_RX
14	GND	P14_25G-KR_TX#	P14_25G-KR_TX	GND	P14_25G-KR_RX#	P14_25G-KR_RX	GND
15	CPU_RS232_RXD	GND	P15_25G-KR_TX#	P15_25G-KR_TX	GND	P15_25G-KR_RX#	P15_25G-KR_RX
16	GND	P16_25G-KR_TX#	P16_25G-KR_TX	GND	P16_25G-KR_RX#	P16_25G-KR_RX	GND

P2 I/O CHART							
	G	F	E	D	C	B	A
1	CPU_DEBUG_1G-T_DA	GND	P17_25G-KR_TX#	P17_25G-KR_TX	GND	P17_25G-KR_RX#	P17_25G-KR_RX
2	GND	P18_25G-KR_TX#	P18_25G-KR_TX	GND	P18_25G-KR_RX#	P18_25G-KR_RX	GND
3	CPU_DEBUG_1G-T_DA#	GND	P19_25G-KR_TX#	P19_25G-KR_TX	GND	P19_25G-KR_RX#	P19_25G-KR_RX
4	GND	P20_25G-KR_TX#	P20_25G-KR_TX	GND	P20_25G-KR_RX#	P20_25G-KR_RX	GND
5	CPU_DEBUG_1G-T_DB	GND	P21_25G-KR_TX#	P21_25G-KR_TX	GND	P21_25G-KR_RX#	P21_25G-KR_RX
6	GND	P22_25G-KR_TX#	P22_25G-KR_TX	GND	P22_25G-KR_RX#	P22_25G-KR_RX	GND
7	CPU_DEBUG_1G-T_DB#	GND	P23_25G-KR_TX#	P23_25G-KR_TX	GND	P23_25G-KR_RX#	P23_25G-KR_RX
8	GND	P24_25G-KR_TX#	P24_25G-KR_TX	GND	P24_25G-KR_RX#	P24_25G-KR_RX	GND
9	CPU_DEBUG_1G-T_DC	GND	P25_25G-KR_TX#	P25_25G-KR_TX	GND	P25_25G-KR_RX#	P25_25G-KR_RX
10	GND	P26_25G-KR_TX#	P26_25G-KR_TX	GND	P26_25G-KR_RX#	P26_25G-KR_RX	GND
11	CPU_DEBUG_1G-T_DC#	GND	P27_25G-KR_TX#	P27_25G-KR_TX	GND	P27_25G-KR_RX#	P27_25G-KR_RX
12	GND	P28_25G-KR_TX#	P28_25G-KR_TX	GND	P28_25G-KR_RX#	P28_25G-KR_RX	GND
13	CPU_DEBUG_1G-T_DD	GND	P29_25G-KR_TX#	P29_25G-KR_TX	GND	P29_25G-KR_RX#	P29_25G-KR_RX
14	GND	P30_25G-KR_TX#	P30_25G-KR_TX	GND	P30_25G-KR_RX#	P29_25G-KR_RX	GND
15	CPU_DEBUG_1G-T_DD#	GND	P31_25G-KR_TX#	P31_25G-KR_TX	GND	P31_25G-KR_RX#	P31_25G-KR_RX
16	GND	P32_25G-KR_TX#	P32_25G-KR_TX	GND	P32_25G-KR_RX#	P32_25G-KR_RX	GND

ORDERING INFORMATION

PART NUMBER	CHANNELS	FIBER INTERFACE	COPPER INTERFACE
CF-020400-584	Up to 8x 1G/10G/25GBASE-SR	2x 24F MT Receptacles	VITA 46 3U VPX

Contact Amphenol for any additional channel count, finishes, and cooling plate.

Interested in this functionality in a different form factor?
Try our CF-020400-62X 2-Bay MT38999 Converter!
Need more functionality? Try the CF-020400-096 3U
VPX 25G 56 channel switch!

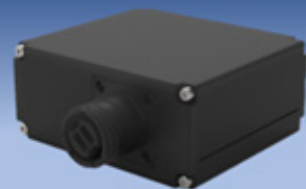

AMPHENOL RUGGEDIZATION DESIGN

OVERVIEW:

Amphenol integrated electronic products are designed and manufactured to our Ruggedization guidelines listed below. These guidelines ensure years of reliable operation in harsh environment applications where extreme operating temperatures, shock, vibration, and corrosive atmospheres are regularly experienced. Unless otherwise noted, the parts conform to the below specifications.

TEMPERATURE:

- Operating Temperature-Thermal Cycles between -40°F(-40°C) to 185°F(+85°C) while device is operating
- Temperature is measured at chassis housing or card edge
- Storage Temperature- Thermal Cycle between -67°F(-55°C) to 257°F(125°C)

HUMIDITY:

- Operating Humidity- Humidity cycle between 0-100% non-condensing humidity while device operating
- Storage Humidity- Humidity cycle between 0-100% condensing humidity

SEALING:

- Sealing can be optionally provided at the MIL-DTL-38999 interface with up to 10-5 cc/sec performance

SHOCK AND VIBRATION:

- Sine Vibration - 10g Peak, 5-2,000Hz
 - Based on a sine sweep duration of 10 minutes per axis in each of three mutually perpendicular axes. May be displacement listed from 5 to 44Hz, depending on specific test.
- Random Vibration - 0.0005 @ Hz, 0.1 @ 15 Hz, 0.1 @2,000 Hz
 - 60 minutes per axis, in each of three mutually perpendicular axes
- 40 G Peak Shock Cycle
 - Three hits in each axis, both direction, 1/2 sine and terminal-peak saw tooth, Total 36 hits.

FLUIDS SUSEPTABILITY:

- MIL-DTL-38999 receptacle interface per EIA-364-10E

ALTITUDE:

- -1,500 to 60,000ft Altitude testing w/ Rapid Depressurization

ELECTROMAGNETIC COMPATIBILITY:

- Designed to comply with MIL-STD-461E

PRINTED CIRCUIT BOARD ASSEMBLIES:

- Conformal Coat
- Amphenol performs Conformal Coating to both sides of printed circuit board assemblies using HUSMISEAL IB31 in accordance with IPC-610, Class 3.
- Printed Circuit Board Rigidity
- Amphenol printed circuit boards are fabricated in accordance with IPC-6012, Class 3.
- Printed Circuit Boards Fabrication
- Amphenol printed circuit boards acceptance criteria is in accordance with IPC-610, Class 3.

RELIABILITY PREDICTIONS (MTBF):

Amphenol can perform Mean Time between Failure (MTBF) reliability analysis in full compliance with MIL-HDBK-217F-1 Parts Count Prediction and MIL-HDBK-217F-1 Parts Stress Analysis Prediction. We can also perform reliability analyses in full compliance of ANSI/VITA 51.1 if it is required or preferred over the later method

Notice: Specifications are subject to change without notice. Contact your nearest Amphenol Corporation Sales Office for the latest specifications. All statements, information and data given herein are believed to be accurate and reliable but are presented without guarantee, warranty, or responsibility of any kind, expressed or implied. Statements or suggestions concerning possible use of our products are made without representation or warranty that any such use is free of patent infringement and are not recommendations to infringe any patent. The user should assume that all safety measures are indicated or that other measures may not be required. Specifications are typical and may not apply to all connectors.

AMPHENOL is a registered trademark of Amphenol Corporation.

©2023 Amphenol Corporation REV: 1/1/2023

Amphenol

MILITARY HIGH SPEED

40-60 Delaware Avenue

Sidney, NY 13838

amphenol-aerospace.com | amphenolmao.com