

CF-02EM250

ENERGY STORAGE MODULE

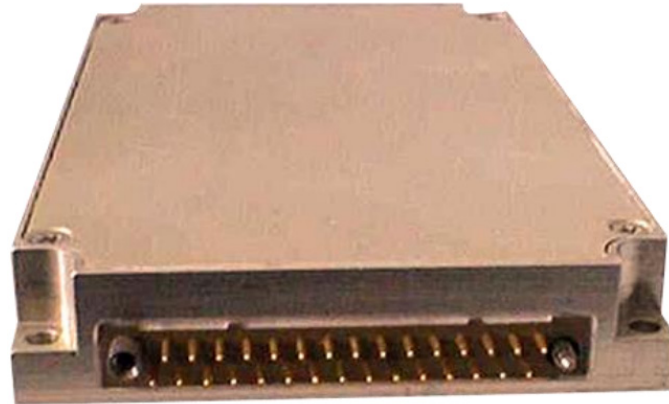

DESCRIPTION

The M250 Series is a compact, high-efficiency energy storage solution designed to meet demanding operational requirements. It features a wide input range and fixed switching frequency. The module includes EMI filters for enhanced noise reduction and supports external synchronization at 250 ± 10 kHz. An integrated capacitor provides a minimum of 1.5 Joules of energy storage, with an option to connect an external capacitor for extended hold-up time. It also offers indicators for input failure and hold-up activation, ensuring continuous monitoring and protection. This module integrates with Milpower Source standard DC/DC converter modules.

FEATURES

- Miniature size
- High efficiency
- Wide input range
- Fixed switching frequency
- External Synchronization (250 ± 10 kHz)
- EMI filters included
- Indication for Input failure and Hold-Up activation
- Internal capacitor stores at least 1.5 Joules.
- External capacitor connection option for additional Hold Up time.
- Operates together with Milpower Source standard DC/DC converter modules. Consult factory for applications.

HOW TO ORDER

PART NUMBER	CF-02EM250	DC-DC Holdup Unit
-------------	------------	-------------------

PRODUCT SPECIFICATIONS:

DC INPUT	
Normal input voltage range:	18 to 48VDC
Input transient protection:	No damage due to abnormal voltage surge IAW MIL-STD-1275A (100V for 50ms) and IAW MIL-STD-704A (80V for 0.1 s)
Steady-state input current:	< 50mA
EMC:	Designed to meet* MIL-STD-461F CE101, CE102, CS101, CS114, CS115, CS116, RE101, RE102, RS101, RS103
Isolation:	Input to Case: 200 VDC
DC OUTPUT	
Output current capacity:	12 A max
Isolation:	Output to Case: 200 VDC

ENVIRONMENTAL CONDITIONS	
Meets or exceeds MIL-STD-810C	
Temperature:	Operating: -55°C to +85°C (baseplate) Storage: -55°C to +125°C
Vibration level:	Up to 9g rms. Consult factory if higher levels required.
Reliability	Minimum 150,000 hours. Calculated IAW MIL-STD-217F Notice 2 at +85°C baseplate, Ground Fix conditions.
Isolation:	Output to Case: 200 VDC

TYPICAL CONNECTION DIAGRAM:

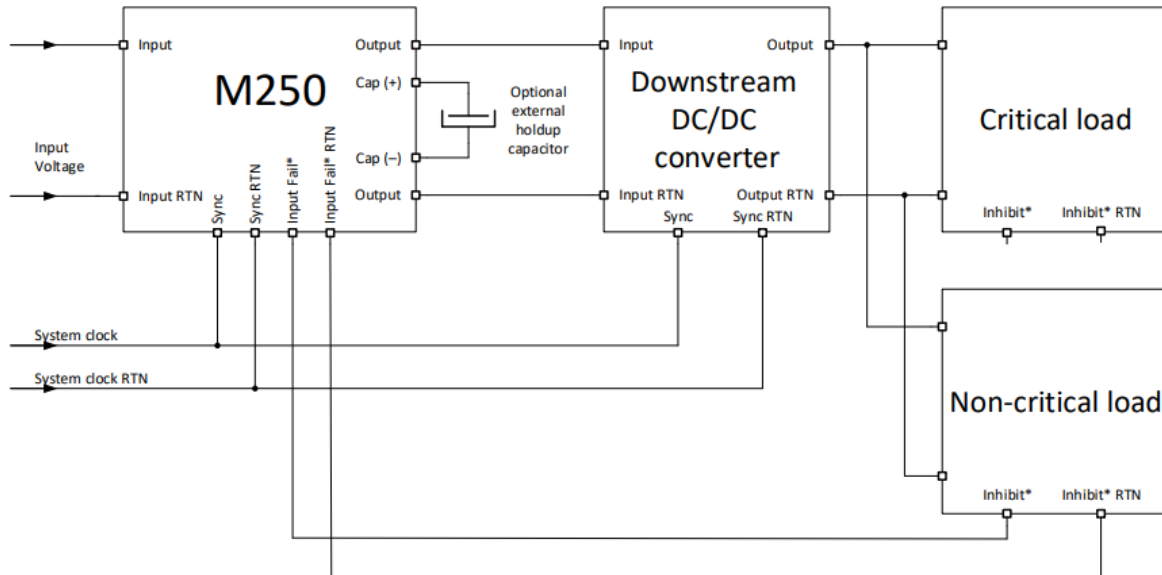

DESCRIPTION OF OPERATION:

This energy storage module should be installed in front of a wide input voltage range DC/DC converter, and not as a standalone. The module provides input voltage for the downstream DC/DC converter when a power failure occurs, such that if the input power returns to normal range within a specific period of time, the downstream DC/DC converter (and therefore the load) can't tell that a power failure had happened.

This unit is designed to be used with most of Milpower Source's DC/DC converters and DC/AC inverters (consult factory for applicability to specific models).

During normal operation, an internal converter charges the internal capacitors (and external, if connected) to 48 to 52V.

In case the input voltage falls below 16V, the input is disconnected from the output via an internal MOSFET switch, and the caps are connected to the output pins through another internal MOSFET switch. The caps are then naturally discharged into the cascaded power supply, until the caps have been depleted to a level that the voltage is below the cascaded power supply's under-voltage lockout threshold (for Milpower Source's converter this value is usually between 16V to 18V).

When input power returns (it can happen during cap discharge or after complete loss of power), the MOSFET switches disconnect the output from the caps, reconnect the input to the output, and the internal converter recharges the caps, preparing them for the next power failure.

PIN ASSIGNMENT:

Connector type: M55302/61-A30 or eq.

Mates with: M55302/66-30H (22 AWG crimp removable contacts)

or M55302/62-A30M (solder cup contacts) or eq.

Pin No.	Function	P	
1	INPUT_FAIL*	+	●
2	INPUT_FAIL* RTN	-	●
3	EXT CAP RTN	-	●
4	EXT CAP	+	●
5	OUTPUT	+	●
6	OUTPUT	+	●
7	OUTPUT	+	●
8	INPUT	+	●
9	INPUT	+	●
10	INPUT	+	●
11	INPUT RTN	-	●
12	INPUT RTN	-	●
13	INPUT RTN	-	●
14	OUTPUT RTN	-	●
15	OUTPUT RTN	-	●

Pin No.	Function	P	
16	SYNC	+	●
17	SYNC RTN	-	●
18	EXT CAP RTN	-	●
19	EXT CAP	+	●
20	OUTPUT	+	●
21	OUTPUT	+	●
22	OUTPUT	+	●
23	INPUT	+	●
24	INPUT	+	●
25	INPUT	+	●
26	INPUT RTN	-	●
27	INPUT RTN	-	●
28	OUTPUT RTN	-	●
29	OUTPUT RTN	-	●
30	OUTPUT RTN	-	●

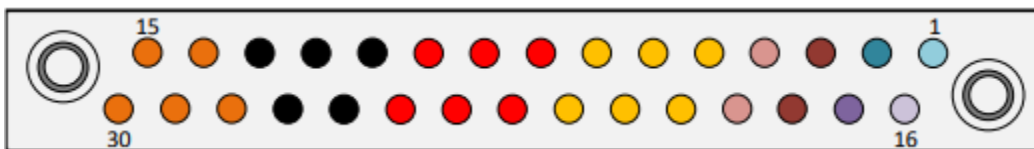

SIGNALS DESCRIPTION:

INPUT FAIL (pin 1)

This signal is used to communicate an input voltage failure condition.
Signal type is open collector of a PMBT2222 bipolar transistor.

FAIL:

Condition: Input voltage was within normal range and dropped below $17.6 \pm 0.5V$.
Result: The pin will be pulled down to INPUT FAIL RTN pin through a 6.2Ω resistor.

NORMAL:

Condition: Input voltage returned to above $17.6 \pm 0.5V$.
Result: The pin will go into high impedance mode (OPEN).
If this function is not required, leave this pin unconnected.
This signal is referenced to INPUT FAIL RTN (pin 2)

SYNC (pin 16)

This signal is used to synchronize the internal switching converter's frequency to external clock.
Valid external clock frequency is $250kHz \pm 10kHz$; Valid duty cycle: $50 \pm 10\%$
When no external clock is present, the power supply uses its internal clock.
If this function is not required, leave pin unconnected.
This signal is referenced to SYNC RTN (pin 17)

EXT CAP (pins 4 and 19)

Connect these pins to external capacitor for increased holdup time.
Unless specified otherwise in the specific variant's catalog page, the voltage at these pins is set to 51VDC.
These pins are referenced to EXT CAP RTN (pins 3 and 18) .

INPUT (pins 8, 9, 10, 23, 24 and 25)

Connect these pins to the input power source.
These pins are referenced to INPUT RTN (11, 12, 13, 26 and 27) and OUTPUT RTN (pins 14, 15, 28, 29 and 30)

OUTPUT (pins 8, 9, 10, 23, 24 and 25)

Connect these pins to the downstream Milpower Source DC/DC converter.
These pins are referenced to OUTPUT RTN (pins 14, 15, 28, 29 and 30) and INPUT RTN (11, 12, 13, 26 and 27)

OUTLINE DRAWING:

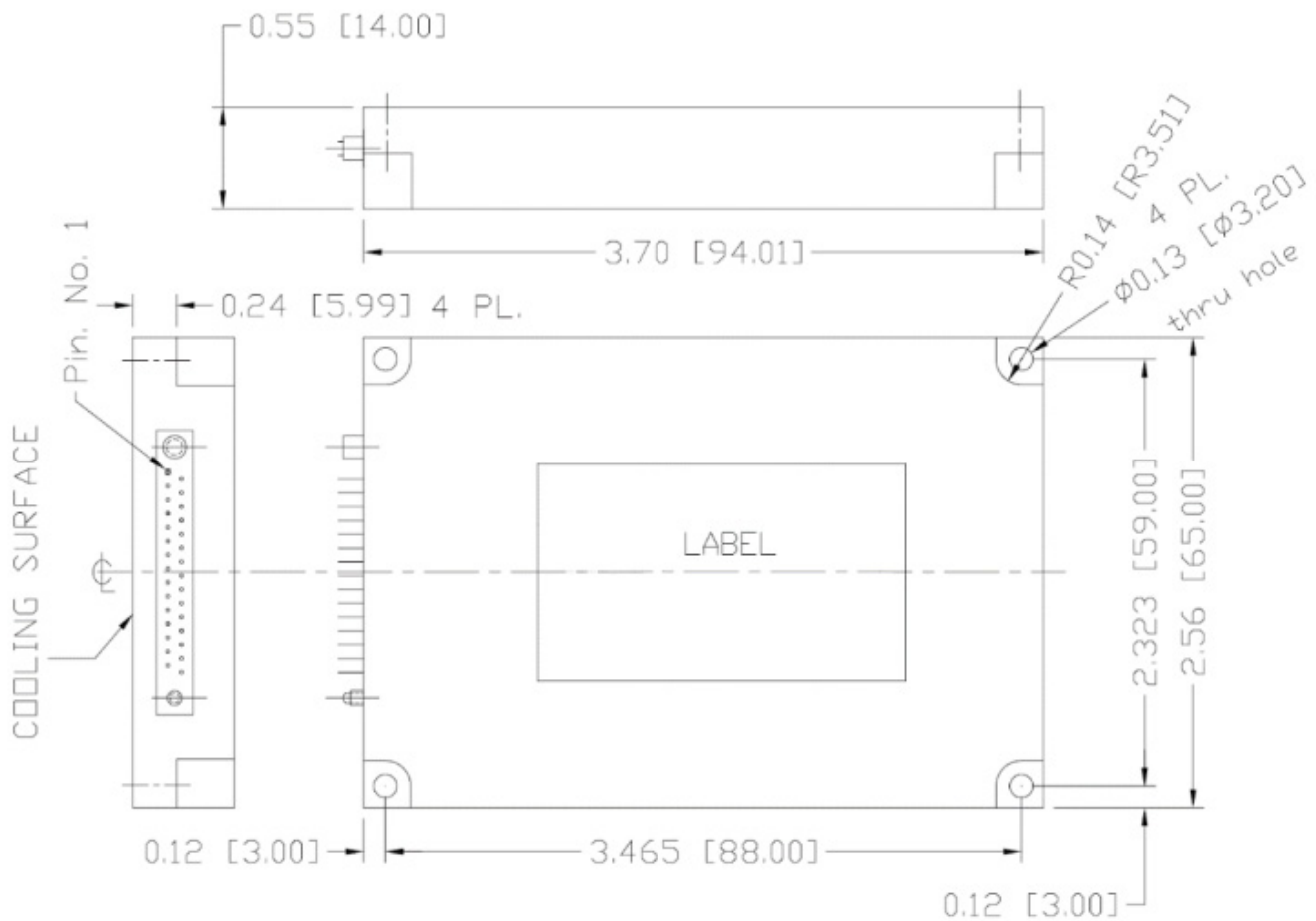

Notes

1. Dimensions are in Inches [mm]
2. Tolerance is:
 - .XX ± 0.01 in
 - .XXX ± 0.005 in
3. Weight: TBD

Notice: Specifications are subject to change without notice. Contact your nearest Amphenol Corporation Sales Office for the latest specifications. All statements, information and data given herein are believed to be accurate and reliable but are presented without guarantee, warranty, or responsibility of any kind, expressed or implied. Statements or suggestions concerning possible use of our products are made without representation or warranty that any such use is free of patent infringement and are not recommendations to infringe any patent. The user should assume that all safety measures are indicated or that other measures may not be required. Specifications are typical and may not apply to all connectors.

AMPHENOL is a registered trademark of Amphenol Corporation.
PRELIMINARY

©2023 Amphenol Corporation REV:



40-60 Delaware Avenue
Sidney, NY 13838
amphenol-aerospace.com | amphenolmao.com