

M4244 SERIES

DC/DC POWER SUPPLY



DESCRIPTION

The M4244 military power supply is a rugged DC to DC converter which accepts an 18 - 70VDC input voltage range and provides a single DC output from 3.3 to 400V at up to 500W. Custom outputs available upon request and the unit is Designed to meet military standards, MIL-STD-704, MIL-STD-1275, MIL-STD-810, MIL-STD-461.

FEATURES

- Miniature size
- High efficiency
- Wide input range
- Input / Output Isolation
- Voltage Sense Compensation
- Fixed switching freq. (250 kHz)
- External sync. capability
- Sync. out capability
- Remote Inhibit
- EMI filters included
- Non-latching protections:
 - o Short-circuit
 - o Over-voltage
 - o Over temperature

HOW TO ORDER

PART NUMBER	INPUT VOLTAGE RANGE	OUTPUT VOLTAGE / CURRENT
CF-	18 to 70 VDC	12 VDC / 30A
CF-	18 to 70 VDC	15 VDC / 30A
CF-	18 to 70 VDC	24 VDC / 20A
CF-	18 to 70 VDC	28 VDC / 17A
CF-	18 to 70 VDC	48 VDC / 10.5A
CF-	18 to 70 VDC	270 VDC / 1.8A
CF-	18 to 70 VDC	270 VDC / 1.8A

ELECTRICAL SPECIFICATIONS

DC Input: Voltage range: 18 to 70 VDC	Normal surge (operational): IAW MIL-STD-1275A-D and MIL-STD-704A-F. MIL-STD-1275E option	Abnormal surge (no damage): IAW MIL-STD-1275A-D (100V for 50ms) and MIL-STD-704A-F (80V for 0.1s)
DC Output: Voltage range: 3.3 to 400VDC Current range: 0 to 30A Power range: 0 to 500W	Output voltage regulation: Less than $\pm 1\%$ (no load to full load, -55°C to $+85^{\circ}\text{C}$ and over normal input voltage range).	Ripple & Noise: Less than 50mVp-p, typical (max. 1%) without external capacitance. When connected to system capacitance ripple drops significantly.
Isolation – Low voltage version: Input to Output: 200VDC Input to Case: 200VDC Output to Case: 200VDC	Isolation –High voltage version: Input to Output: 500VDC Input to Case: 200VDC Output to Case: 500VDC	EMC: Designed to meet* MIL-STD-461F CE101, CE102, CS101, CS114, CS115, CS116, RE101, RE102, RS101, RS103
Transient over-and-undershoot: Output resistance at load change of 50% to 100% is 30 to 120m Ω (depending on output voltage). Output returns to steady-state value within 300 to 500 μs	Efficiency: Typically, 80 to 85% (28VDC or 270VDC output, full load, nominal input voltage, room temperature)	Turn-on transient: No Voltage overshoot during power on.

PROTECTIONS

Input	Output	General
Under-Voltage Lock-Out: Unit shuts down below 16V ± 1.5V.	Active Over-Voltage Protection: Internal control shuts output voltage down if it exceeds 110% ±5% of nominal voltage	Over Temperature Protection: Unit shuts down if baseplate temperature rises above +105°C ± 5°C. Automatic recovery when baseplate temperature falls below +95°C ± 5°C.
Over-Voltage Lock-Out: Unit shuts down above 52V ± 2V.	Passive Over-Voltage Protection: Transorb assembled across the output pins, selected at 120% ±10% of nominal voltage.	
	Under-Voltage Protection: Internal control shuts output voltage down (hiccup) if falls below 85% ± 5% of nominal voltage	
	Current Limiting: Continuous protection (10-30% above maximum current) for unlimited time (Hiccup).	

ENVIRONMENTAL CONDITIONS

Temperature: Operating: -55 °C to +85 °C (at baseplate) Storage: -55 °C to +125 °C	Altitude: Method 500.4 Procedures I & II Up to 70,000 ft. Operational	Salt Fog: Method 509.4
Humidity: Method 507.4 Procedure I Up to 95% RH	Vibration (random): Method 514.5 Category 24 – General minimum integrity exposure IAW Figure 514.5C-17 1 hour per axis.	Shock: Method 516.5 Procedure I – Functional shock Saw-tooth, 20g peak, 11 ms

TYPICAL EFFICIENCY CURVES

270 V_{DC} output version:

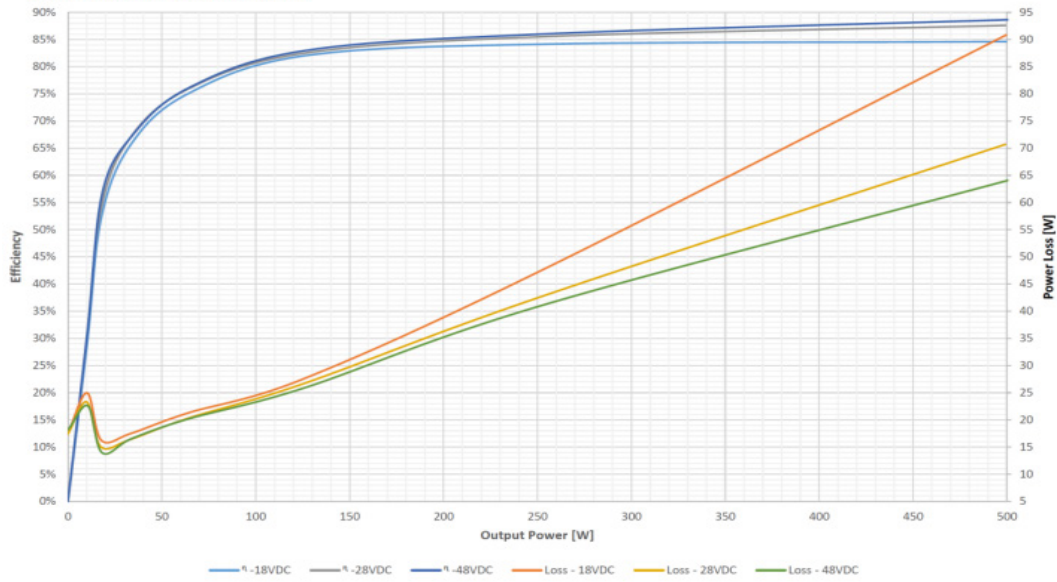

28 V_{DC} output version:

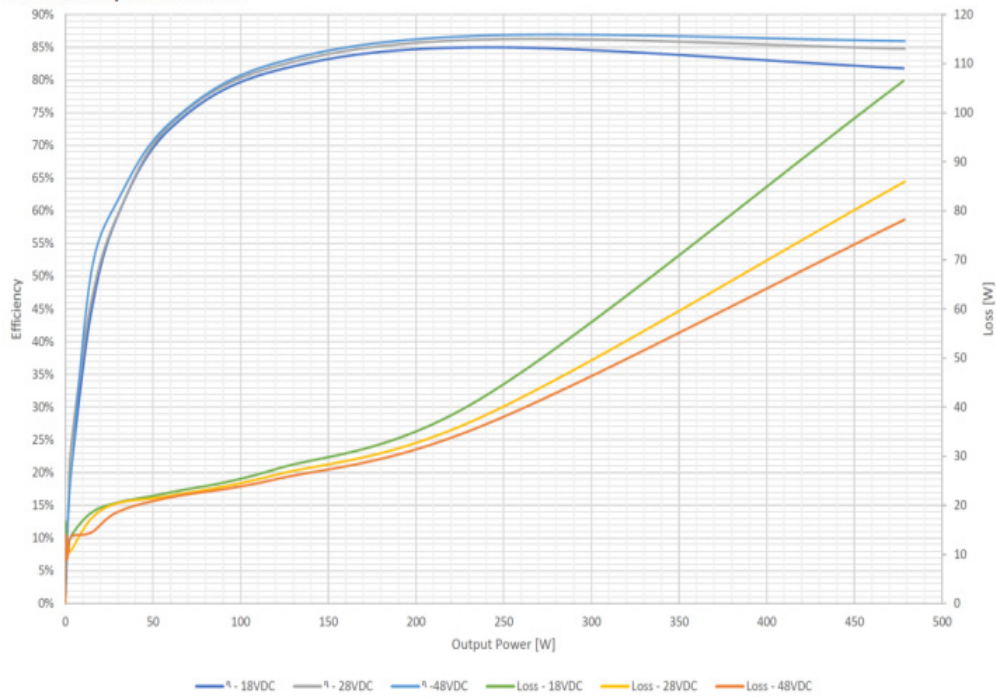

PIN ASSIGNMENT

J1 - Input Connector

Type: M24308/24-39F or eq.

Mates with: M24308/2-3F or eq.

Pin #	Function	P	
1	INPUT	+	●
2	INPUT	+	●
3	INPUT	+	●
4	INPUT	+	●
5	N.C.		
6	INPUT RTN	-	●
7	INPUT RTN	-	●
8	INPUT RTN	-	●
9	INPUT RTN	-	●

Pin #	Function	P	
10	CHASSIS		●
11	SYNC IN	+	●
12	INHIBIT IN	+	●
13	SIGNAL RTN	-	●
14	INPUT	+	●
15	INPUT	+	●
16	INPUT	+	●
17	INPUT	+	●
18	N.C.		

Pin #	Function	P	
19	INPUT RTN	-	●
20	INPUT RTN	-	●
21	INPUT RTN	-	●
22	INPUT RTN	-	●
23	N.C.		
24	INHIBIT OUT		○
25	SYNC OUT		●

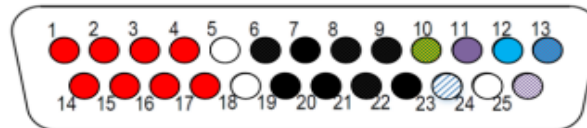

J2 - Output Connector

Type: M24308/23-38F or eq.

Mates with: M24308/4-2F or eq.

Pin #	Function	P	
1	OUTPUT	+	●
2	OUTPUT	+	●
3	OUTPUT	+	●
4	N.C.		●
5	OUTPUT RTN	-	●

Pin #	Function		
6	OUTPUT RTN	-	●
7	OUTPUT RTN	-	●
8	N.C.		
9	OUTPUT	+	●
10	OUTPUT	+	●

Pin #	Function	P	
11	OUTPUT	+	●
12	N.C.		
13	OUTPUT RTN	-	●
14	OUTPUT RTN	-	●
15	OUTPUT RTN	-	●

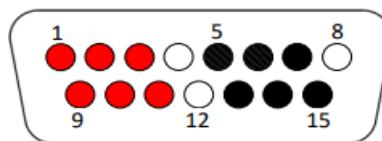

FUNCTIONS AND SIGNALS

INHIBIT IN

The INHIBIT signal is used to turn the power supply ON and OFF.
TTL “1” or OPEN – Power supply active (output turned on).
TTL “0” or SHORT to Signal RTN – Power supply inhibited (output turned off).
If this function is not required, leave this pin unconnected.

INHIBIT OUT

Used when connecting two units or more in parallel. Connect this signal to the INHIBIT IN pin of the slave unit (see diagram below). This signal synchronizes the shutdown and startup of the units.

SYNC IN signal

The SYNC IN signal is used to allow the power supply frequency to sync with the system frequency.
The system frequency can be $250\text{kHz} \pm 10\text{kHz}$.
When not connected the power supply will work at $250\text{kHz} \pm 10\text{kHz}$
POWER GOOD (Pin #9)

SYNC OUT signal

The SYNC OUT signal is used to sync the system and / or other power supplies with the power supply's frequency.

SIGNAL RTN

The SIGNAL RTN is referred to the input.
This pin is used as a return path for SYNC IN, SYNC OUT and INHIBIT IN.

TYPICAL CONNECTION DIAGRAM

Single Converter Operation

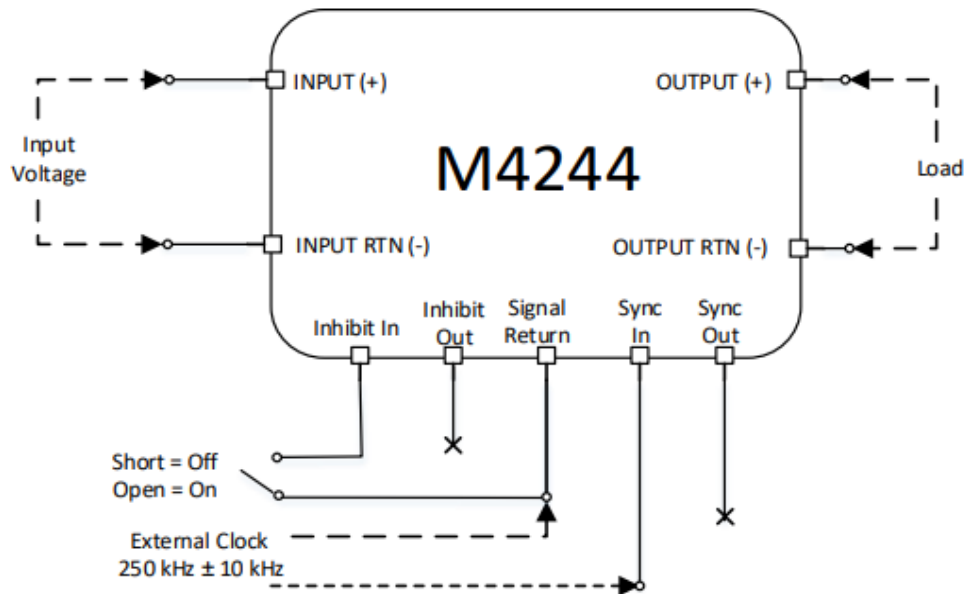

Parallel connection operation

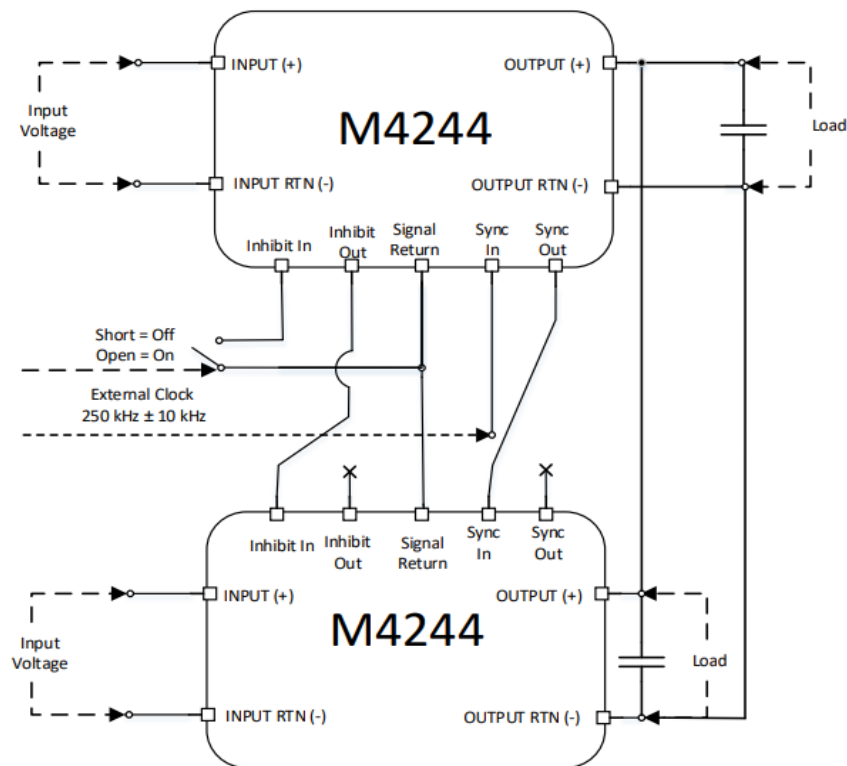

OUTLINE DRAWING

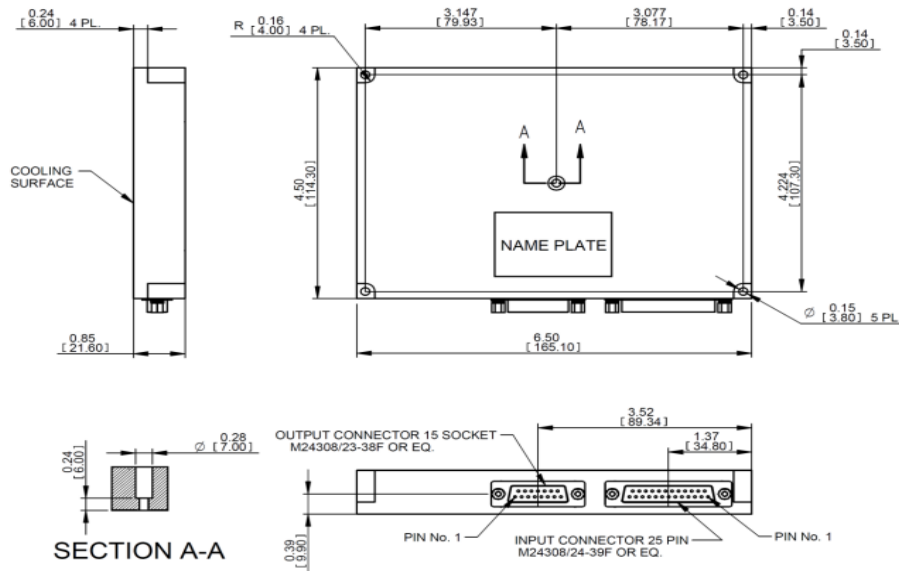

Notes

1. Dimensions are in inches [mm]
2. Tolerance is:
.XX ± 0.01 in
.XXX ± 0.005 in
3. Weight: Approx. 25.5 oz [725 g]

HEAT DISSIPATION SURFACE

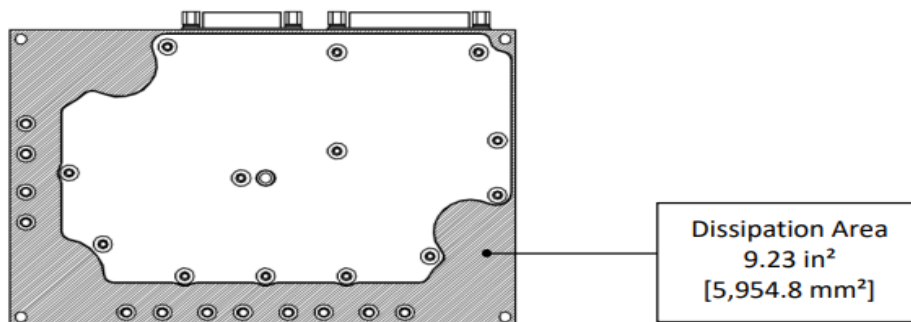

Notice: Specifications are subject to change without notice. Contact your nearest Amphenol Corporation Sales Office for the latest specifications. All statements, information and data given herein are believed to be accurate and reliable but are presented without guarantee, warranty, or responsibility of any kind, expressed or implied. Statements or suggestions concerning possible use of our products are made without representation or warranty that any such use is free of patent infringement and are not recommendations to infringe any patent. The user should assume that all safety measures are indicated or that other measures may not be required. Specifications are typical and may not apply to all connectors.

AMPHENOL is a registered trademark of Amphenol Corporation.
PRELIMINARY

©2023 Amphenol Corporation REV:



40-60 Delaware Avenue
Sidney, NY 13838
amphenol-aerospace.com | amphenolmao.com

Jared Sibrava | +1 (607) 643-1845 | jsibrava@amphenol-ao.com
amphenol-aerospace.com