

# M495-102

24VDC OUTPUT, 600W

AC/DC CONVERTER FOR PERMANENT MAGNET  
GENERATOR (PMG) APPLICATIONS.



M495-102 is a 600W non-isolated AC/DC converter.

The converter has a wide input supply range of 25Vrms (line to line) to 135V rms (line to line) and requires no minimum load for normal operation.

The converter has two D-type connectors for input and output.

In addition to the power lines the converter has an option for RPM signal responding according to line frequency, output voltage status discrete and input voltage analog signal.

The M495-102 is air forced cooled unit.

The unit has small cooling fins and fairly close to each other which is the design for forced cooling air (the unit usually mounted near engine in a UAV application) and have airflow from that direction.

The unit need about 12CFM for keeping operation at 60C ambient.

## M495-102 – AC/DC CONVERTER FOR PMG

### THE MAIN FEATURES OF THE M8139 ARE:

- Non-isolated AC/DC converter
- Wide input supply range of 25Vrms (line to line) to 135V rms (line to line)
- For extended input version - **Please contact factory for more details**
- two D-type connectors for input and output
- 600W non-isolated AC/DC converter
- Built-in EMI Input & Output Filters
- 25V<sub>line to line</sub>-135 V<sub>line to line</sub> input voltage range, compatible with the rectified output of most PMG's.
- Overload, Over-voltage and Over-temp protections
- Compatible with permanent magnet generator characteristics
- No external capacitors required
- No minimum load required
- Air forced cooled
- BIT output.
- Upon request, the output voltage can be factory trimmed above or below 24Vdc.

### How to Order:

Part Number
M495102

## M495-102 – AC/DC CONVERTER FOR PMG

### SPECIFICATIONS:

<b>DC Input</b>	<b>Voltage and Frequency</b>	Normal range: 25Vline to line-135 Vline to line 133Hz – 400Hz
	<b>Isolation</b>	Input to Chassis: 500VDC
<b>DC Output</b>	<b>Rating</b>	24V / 25A
	<b>Ripple</b>	Less than 500 mVp-p, typical
	<b>Isolation</b>	Output to Chassis: 500VDC
	<b>Current Limit &amp; Overload</b>	<b>SHORT CIRCUIT PROTECTION WITH AUTO-RECOVERY</b> When output is overloaded (typical above 27A)output voltage is reduced as a result of the overload. The converter has a fold back type protection. At short conditions output current drops to about 10A in order to reduce dissipated power.
	<b>Efficiency</b>	See table on page 5
	<b>Overvoltage Protection</b>	<b>OVERVOLTAGE PROTECTION WITH AUTO-RECOVERY</b> The power supply contains an over voltage circuit that operates a shut down to the PWM circuit.

## M495-102 – AC/DC CONVERTER FOR PMG

### SPECIFICATIONS (CONT.):

<b>Control &amp; Indication</b>	<b>Functions and Signals</b>	<p><b>VIN BIT</b> This signal is used to indicate the input voltage of the generator.</p> <p><b>RPM</b> This signal is used to indicate the RPM value of the generator.</p> <p><b>Under VOUT BIT</b> The BIT output is an Open/Short type logic signal that indicates that the M495 is operating properly. The BIT signal is designed to interface with a 51 Ω pull-up resistor (on the receiving side). When no-fault detected (<math>20 &lt; V_{out} &lt; 24</math>) the signal will be short through 51Ω, when a fault is detected (<math>15 &lt; V_{out} &lt; 17</math>), the signal will be an open drain.</p>
<b>Environment Designed to meet MIL-STD-810F</b>	<b>Temperature</b>	Operating: -40°C to +85°C (at the bottom of the cooling fins) Storage: -40°C to +85°C
	<b>Humidity</b>	Method 507.4 - Up to 95% RH
	<b>Salt-fog</b>	Method 509.4
	<b>Mechanical Shock</b>	Saw-tooth 20g peak 10 msec
	<b>Vibration</b>	0.05 g <sup>2</sup> /Hz, 50Hz-2kHz
<b>Fungus</b>	Does not support fungus growth, in accordance with the guidelines of MIL-STD-454, Requirement 4.	
<b>EMI</b>	Built-in EMI Input & Output Filters	
<b>Cooling Requirements</b>	The unit has small cooling fins and fairly close to each other which is the design for forced cooling air (the unit usually mounted near engine in a UAV application) and have airflow from that direction.	
<b>Form factor</b>	12mm wide, 40mm high, 90mm long, for detailed dimensions and tolerances see Drawing: M495001	
<b>Weight</b>	580gr	
<b>Connectors</b>	See Page 8	

## M495-102 – AC/DC CONVERTER FOR PMG

### ELECTRICAL CHARACTERISTIC

Unless otherwise specified:  $V_{in} = 30$  to  $200$  Vdc,  $T(amb) = -40^{\circ}\text{C}$  to  $+71^{\circ}\text{C}$ ,  $T(base) \leq 85^{\circ}\text{C}$ .

PARAMETER	CONDITIONS	MIN.	TYP.	MAX.
Recommended Input voltage (line to line)	---	25 V <sub>rms</sub>		135 V <sub>rms</sub>
Output voltage	$I_{out} = 25\text{A}$	23.0 V <sub>DC</sub>	24.0	25.0 V <sub>DC</sub>
Output current	$V_{in} > 25\text{V}$	25A		
Efficiency Line / Load regulation	$V_{in} = 80\text{V} / \text{max rated } P_{out}$		90%	
	$V_{in} = 25\text{V to } 135\text{V}$ $P_{out} = 10\% \text{ to max rated } P_{out}$			±500 mV
Output ripple	Full load (resistive) with 0.1μF, 20MHz BW			1 V <sub>p-p</sub>
Input EMI current @ 600kHz	Input terminated through LISN			90 dBμA
Current limit threshold	$V_{in} = 90\text{V}$	15A		
Output turn-on time	$V_{in} > 25\text{V}$			200 msec
Bit OK signal Bit signal = short through 51Ω	$V_{out}$ ok threshold	20V		24V
Bit OK fault level Bit signal = open	$V_{out}$ fault threshold	15V		17V
Frequency at which turn-on is enabled Recommended Input voltage (line to line)	Output loaded with full load equivalent resistor ---	300 Hz		400 Hz

**M495-102 – AC/DC CONVERTER FOR PMG**

**PIN ASSIGNMENT: Input Connector J1**

**Connector type:** M24308/24-38 or eq.

**Mates with:** M24308/1-2 or eq.

PIN No.	Function
6,7,8,14,15	Phase A
4,5,11,12,13	Phase B
1,2,3,9,10	Phase C

**PIN ASSIGNMENT: OUTPUT CONNECTOR J2**

**Connector type:** M24308/23-27 or eq.

**Mates with:** M24308/3-3 or eq.

PIN No.	Description
1	VIN BIT
2	RPM
3-7,15-20	VOUT
8-13, 21-25	VOUT RTN
14	Under VOUT BIT

**Note:** All pins with identical function/designation should be connected together for optimal performance.

**M495-102 – AC/DC CONVERTER FOR PMG**

**OUTLINE DRAWING**

For detailed dimensions and tolerances see Drawing M495001

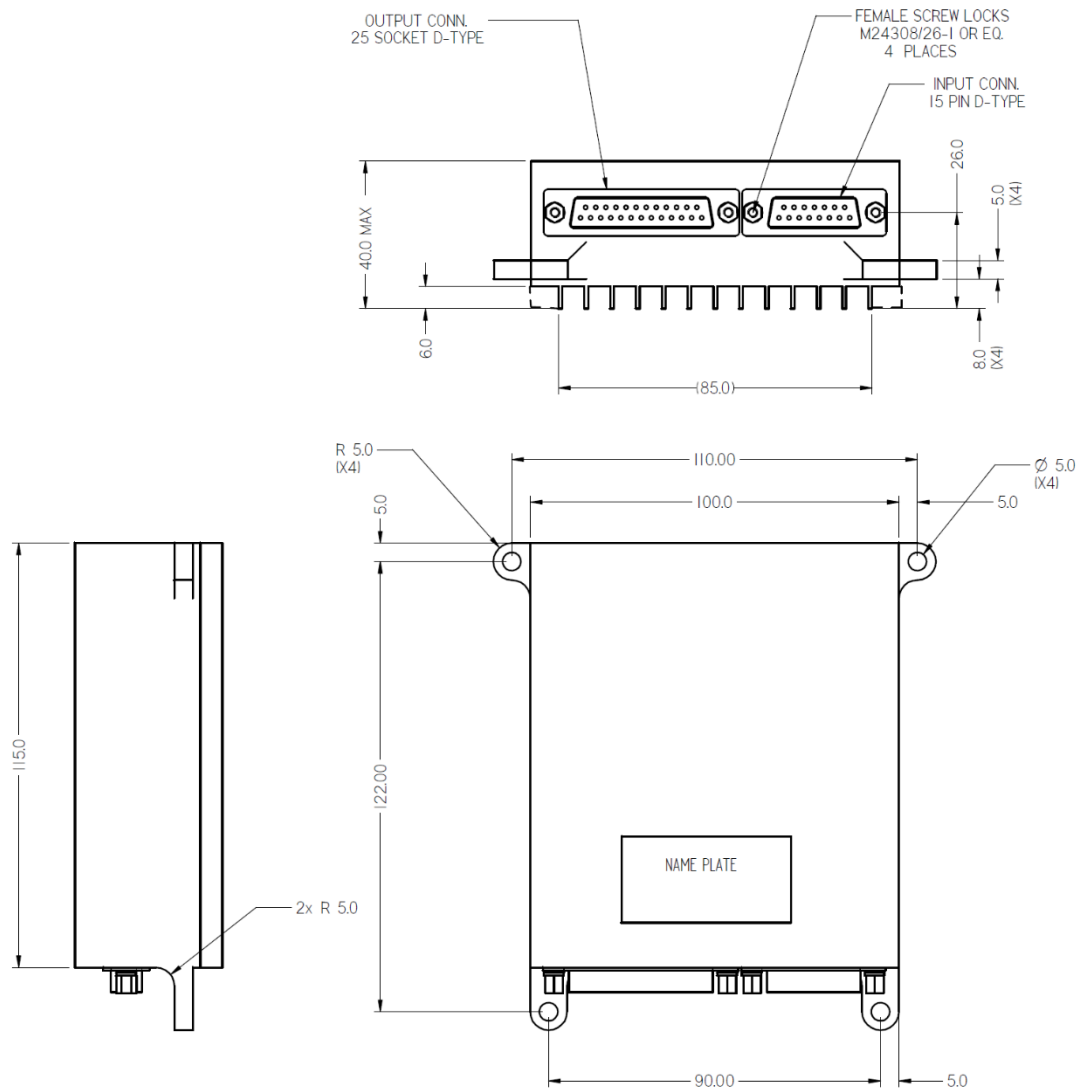

*Note: Specifications are subject to change without prior notice by the manufacturer.*