

M7019 SERIES

DC/DC POWER SUPPLY



DESCRIPTION

The M7019 military power supply is a rugged DC to DC converter which accepts an 18 - 48VDC input voltage range and provides a single DC output from 3.3 to 56V at up to 100W. Custom outputs available upon request and the unit is Designed to meet military standards, MIL-STD-704, MIL-STD-1275, MIL-STD-810, MIL-STD-461.

FEATURES

- Miniature size
- High efficiency
- Input / Output isolation
- Fixed switching freq.
- EMI filters included
- Remote inhibit (On/Off)
- Non-latching protections:
 - Overload/short-circuit
 - Over-voltage
 - Over temperature

HOW TO ORDER

Part Number	Output Voltage	Max Output Current	Minimum Efficiency
CF-02EM7019-1	5VDC	13A	82%
CF-02EM7019-2	12VDC	8A	83%
CF-02EM7019-3	15VDC	7A	84%
CF-02EM7019-4	24VDC	4A	85%
CF-02EM7019-5	28VDC	3.5A	86%

ELECTRICAL SPECIFICATIONS

<p><u>DC Input Standard Version</u></p> <p>Normal steady-state voltage range: 18 to 48VDC</p>	<p><u>DC Output</u></p> <p>Voltage range: 3.3 to 56V Current range: 0 to 15A Power range: 0 to 100W</p>	<p><u>Isolation</u></p> <p>Input to Output: 200VDC Input to Case: 200VDC Output to Case: 100VDC</p>
<p><u>Extended Input Option</u></p> <p>IAW MIL-STD-1275E (12 to 100 VDC) IAW MIL-STD-704A-F (6 to 80 VDC)</p>	<p><u>Efficiency</u></p> <p>87% typical (28V variant, at nominal input voltage, full load, room temperature)</p>	<p><u>EMC</u></p> <p>Designed to meet* MIL-STD-461F CE101, CE102, CS101, CS114, CS115, CS116, RE101, RE102, RS101, RS103.</p>
<p><u>Output voltage regulation</u></p> <p>Less than $\pm 1\%$ (low to high input voltage, no load to full load, $-55\text{ }^{\circ}\text{C}$ to $+85\text{ }^{\circ}\text{C}$ at baseplate).</p>	<p><u>Ripple and Noise</u></p> <p>100-150 mVp-p, typical (max. 1%) without external capacitance.</p>	<p><u>Turn on Transient</u></p> <p>No overshoot.</p>

PROTECTIONS

<u>Input</u>	<u>Output</u>	<u>General</u>
<p>Under-Voltage Lockout Standard version converter shuts if input voltage is below $16 \pm 1V$.</p> <p>Over-Voltage Lockout Standard version converter shuts down if input voltage is above $53 \pm 1V$.</p>	<p>Active Over-Voltage Protection Secondary control circuit takes over if output voltage exceeds $110\% \pm 5\%$ of nominal voltage.</p> <p>Passive Over-Voltage Protection Transorb at output selected $20\% \pm 5\%$ above nominal voltage.</p>	<p>Over Temperature Protection Shutdown if baseplate temperature exceeds $+105^{\circ}C \pm 5^{\circ}C$. Automatic recovery upon cooldown to below $+95^{\circ}C \pm 5^{\circ}C$.</p>
<p>Reverse Polarity Protection</p> <p>Protection for unlimited time.</p>	<p>Overload / Short-Circuit Protection</p> <p>Output voltage turns off and on periodically with low duty-cycle (hiccup) to protect system conductors and converter from short circuit and overload.</p>	

ENVIRONMENTAL CONDITIONS

Designed to meet MIL-STD-810F

<p><u>Temperature</u></p> <p>Methods 501.5 & 502.5 Operating: $-55^{\circ}C$ to $+85^{\circ}C$ (at baseplate) Storage: $-55^{\circ}C$ to $+125^{\circ}C$ (ambient)</p> <p><u>Altitude</u></p> <p>Method 500.5 Procedures I – up to 70,000 ft. (non-operational) Procedure II – up to 70,000 ft. (operational)</p> <p><u>Humidity</u></p> <p>Method 507.5 Up to 95% RH</p>	<p><u>Vibration</u></p> <p>Method 514.6 Category 7: Aircraft – Jet, IAW figure C-6, 13.7grams, 1 hour per axis. Category 24: Minimum integrity, IAW figure E-3, 7.7 grams, 1 hour per axis.</p> <p><u>Shock</u></p> <p>Method 516.6 Operational shock: 30 g, 11 ms, half-sine Crash safety: 100 g, 6 ms, half-sine</p> <p><u>Salt Fog</u></p> <p>Method 509.4</p>
--	--

Test results

CE102 MIL-STD-461F Conducted Emission, 10 kHz -150 kHz

Line (nominal input voltage, full load)

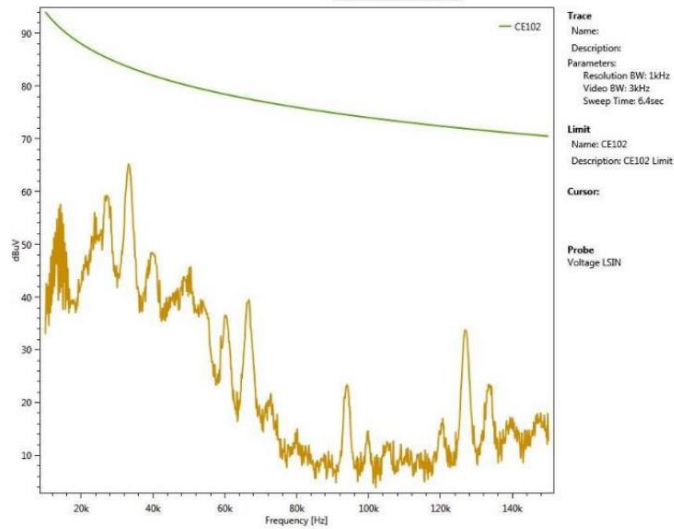

CE102 MIL-STD-461F Conducted Emission, 10 kHz -150 kHz

Return (nominal input voltage, full load)

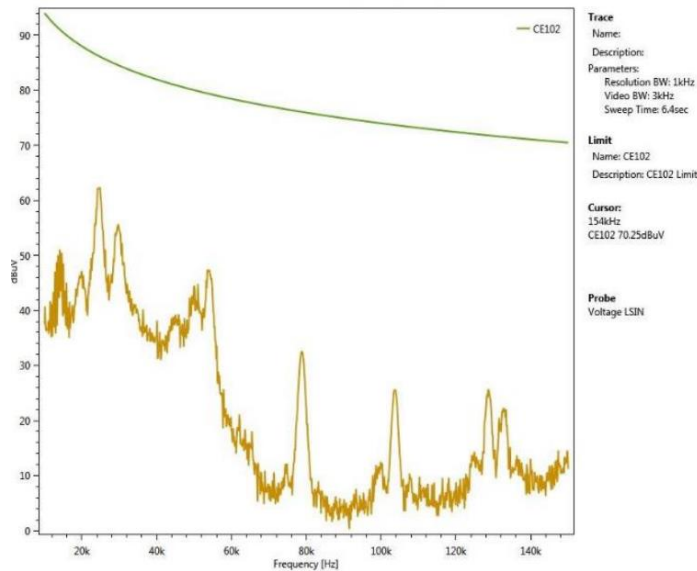

CE102 MIL-STD-461F Conducted Emission, 150 kHz - 10 MHz

Line (nominal input voltage, full load)

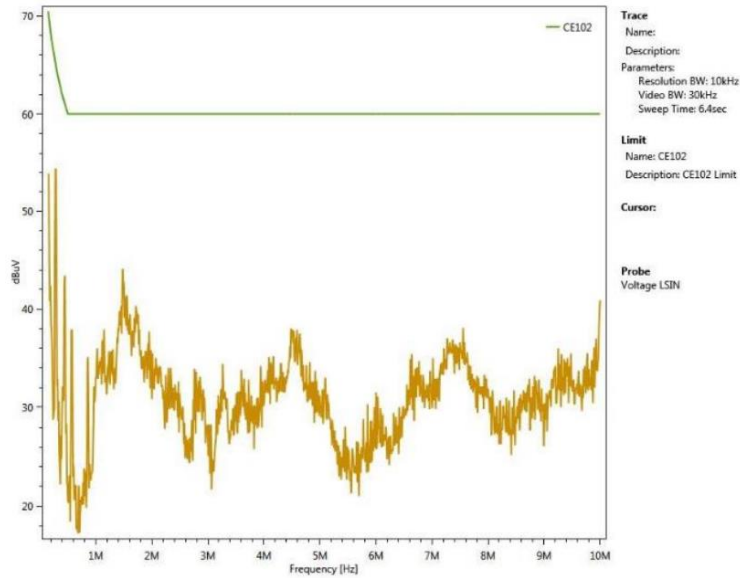

CE102 MIL-STD-461F Conducted Emission, 150 kHz - 10 MHz

Return (nominal input voltage, full load)

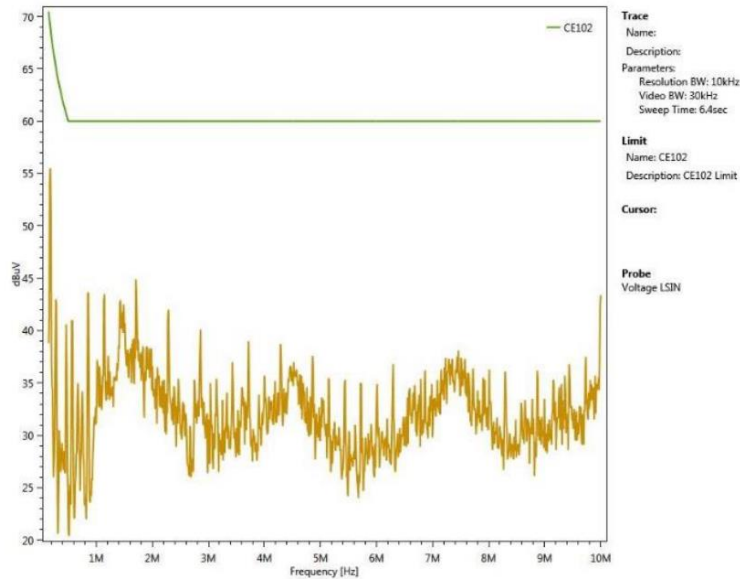

FUNCTIONS AND SIGNALS

INHIBIT (pin 8)

Description: The INHIBIT signal is used to turn the power supply ON and OFF.

Operation: Applying “1” or leaving open will turn the power supply ON. For constant operation, leave this pin unconnected.

Applying “0” or shorting this pin to its return line will turn the power supply OFF.

(Optional to change the logic of this signal. Please consult with factory.)

Signal Type: 5V TTL or dry contact (open/short).

Return line: This signal is referenced to INPUT RTN pin

Optional to change the logic of this signal. Please consult with the factory

SENSE (pin 2) & SENSE RTN (pin 3)

Description: The SENSE is used to compensate for voltage drop across the output wires by sensing the voltage at the load and correcting the increasing the output voltage accordingly, to provide the desired voltage at the load's terminals.

Operation: Connect the SENSE pin to the positive load terminal, and the SENSE RTN pin to the negative (return) load terminal.

The sense compensation is typically limited to 5% or 0.5V – the lesser of the two.

Note: If not used, connect SENSE directly to OUTPUT pins, and the SENSE RTN pin directly to the OUTPUT RTN pins.

DO NOT LEAVE THE SENSE/SENSE RTN PINS UNCONNECTED- the output voltage will increase by 5% to 8%.

PIN ASSIGNMENT

Connector: M24308/24-38F or eq.

Mates with: M24308/2-2F or eq.

Pin No.	Function		
1	OUTPUT	+	●
2	SENSE	+	◐
3	SENSE RTN	-	◑
4	OUTPUT RTN	-	●
5	OUTPUT RTN	-	●
6	INPUT RTN	-	●
7	INPUT	+	●
8	INHIBIT	+	●

Pin No.	Function		
9	OUTPUT	+	●
10	OUTPUT	+	●
11	OUTPUT	+	●
12	OUTPUT RTN	-	●
13	OUTPUT RTN	-	●
14	INPUT RTN	-	●
15	INPUT	+	●

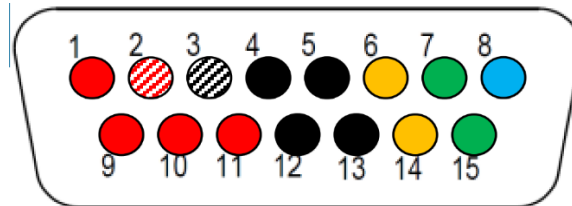

Outline Drawing

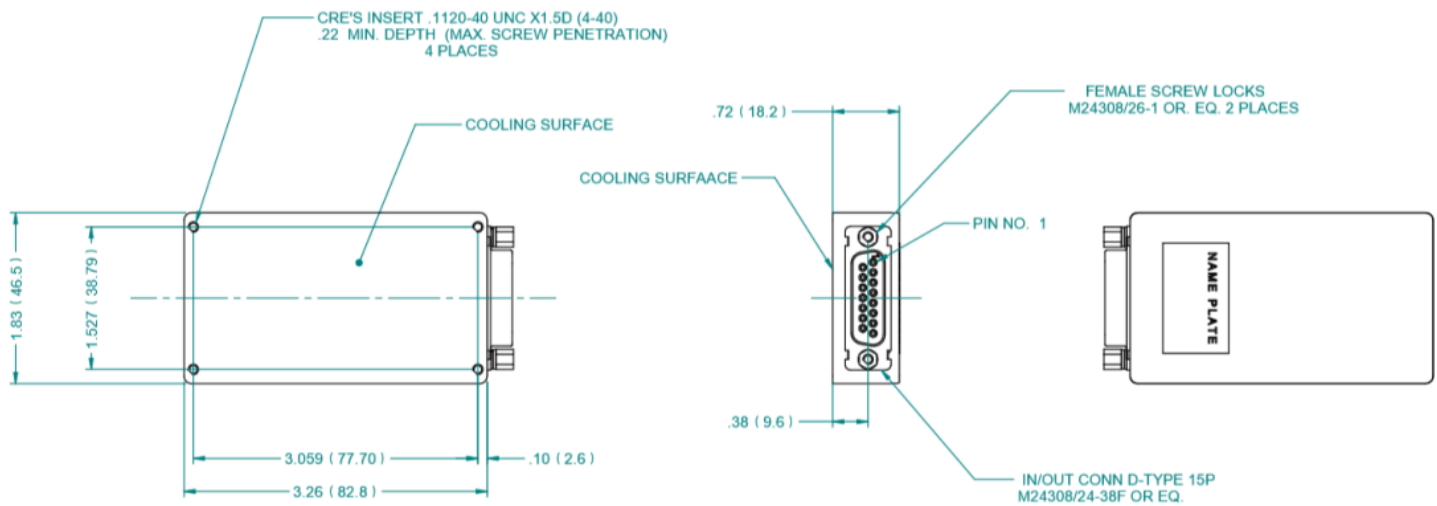

Notes

1. Dimensions are in inches [mm]
2. Tolerance is:
 - .XX ± 0.02 in
 - .XXX ± 0.010 in
3. Weight: 134 g

Notice: Specifications are subject to change without notice. Contact your nearest Amphenol Corporation Sales Office for the latest specifications. All statements, information and data given herein are believed to be accurate and reliable but are presented without guarantee, warranty, or responsibility of any kind, expressed or implied. Statements or suggestions concerning possible use of our products are made without representation or warranty that any such use is free of patent infringement and are not recommendations to infringe any patent. The user should assume that all safety measures are indicated or that other measures may not be required. Specifications are typical and may not apply to all connectors.

AMPHENOL is a registered trademark of Amphenol Corporation.

©2023 Amphenol Corporation REV: PRELIMINARY

Amphenol

MILITARY HIGH SPEED

40-60 Delaware Avenue

Sidney, NY 13838

amphenol-aerospace.com | amphenolmao.com