

PoEBlox

Compact 360W PoE Switch

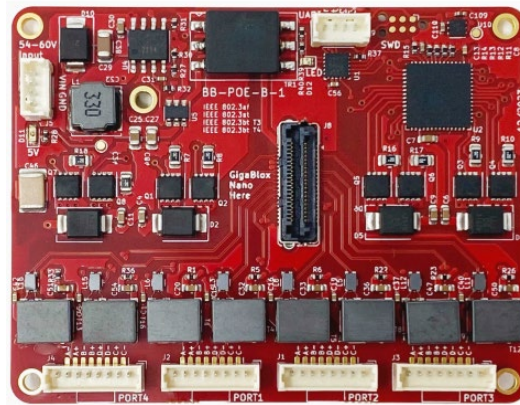

DESCRIPTION

PoEBlox is a daughterboard that provides up to 90W power over ethernet on four gigabit ethernet ports. It is designed as a power delivery daughterboard for GigaBlox Nano, which together forms a 4 port gigabit ethernet switch with PoE capability up to 90W per port. PoEBlox achieves this with the use of an active PSE controller, onboard power FETs, and high transformers, all while retaining a very compact form factor of 65mm x 50mm. This system can provide data and power to any active PoE device, drastically simplifying the construction of PoE based embedded systems.

FEATURES

- Four IEEE802.3bt 4-pair ports with 1000BASE-T (gigabit Ethernet data pass-through)
- 90W PoE injection IEEE 802.3bt on each port
- Input voltage range from 48 to 57V
- Transient protected voltage input
- -40 oC to 85 oC Operation Range
- 65mm x 50mm board size
- RazorBeam connector compatible with GigaBlox Nano
- Molex PicoBlade connector for power and ethernet ports
- Onboard microcontroller and serial port for PSE management (currently unimplemented)

HOW TO ORDER

Part Number	CF-02BBPOE	PoEBlox
	CF-02BBPOENDAA	PoEBlox – NDAA Compliant

GENERAL SPECIFICATIONS

Voltage Input	48V to 57V DC (70V absolute max, 18V min for data)
PoE Maximum Power Output	360W (IEEE 802.3bt)
Supported Ethernet Protocols	10BASE-T, 100BASE-TX, 1000BASE-T
Supported PoE Protocols	IEEE 802.3af, IEEE 802.3at, IEEE 802.3bt (Type 3/4)
Power Consumption (not including PoE load)	2W
Weight	16 grams
Size	65 mm x 50 mm x 14.5 mm (when assembled with BB-GGN-A-1)
Operating Temperature	-40°C to +85°C
Storage Temperature	-55°C to +125°C

GENERAL OPERATING INSTRUCTIONS

PoEBlox is designed for use in commercial and industrial environments. To be able to operate full PoE switch function, the minimum PSE port voltage is 48 VDC for type 1, 50 V for type 2 and type 3, and 52 V for type 4. PoEBlox can still pass data when the input voltage is below 48V but PoE will not work.

In the simplest case, PoEBlox can be operated immediately by following the following steps.

- Connect GigaBlox Nano to the RazorBeam connector on PoEBlox board
- Connect powered devices (PDs) to the RJ45 ports
- Apply a voltage between 48V to 57V to the voltage input terminals.
- PoEBlox will detect PDs that have a valid signature, complete mutual identification, and apply power. Along with that, GigaBlox Nano will begin functioning as an unmanaged 10/100/1000Mbit/s network switch. There is no need to select the PoE mode on PoEBlox

SAFETY INFORMATION

- This device can operate on voltages near and above 60V. Please read this manual before operating.

- This device is provided “as is”. In-application testing prior to integration is recommended.
- This device is provided as an electronic circuit board, and requires integration into chassis for full ingress protection.
- Do not use this product in wet environments without integrating into a chassis.
- Do not operate this product beyond the rated temperature and voltages.

BLOCK DIAGRAM

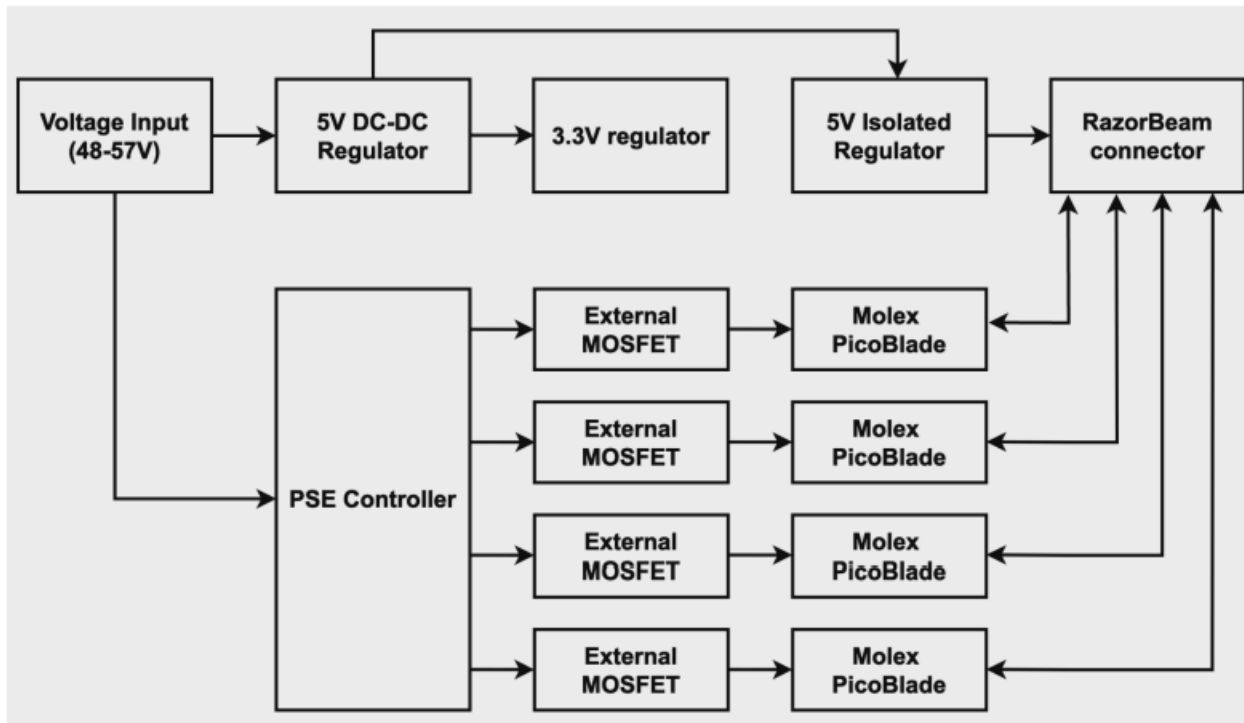

INCLUDED EQUIPMENT

The product includes the following:

1 x BB-POE-B-1 (PoEBlox board)

1 x BB-PBTL1-4-0.3 (Molex PicoBlade to Tinned Leads, 4 way, 0.3 meters, power cable)

4 x BB-PBRJ1-8-0.3 (Molex PicoBlade to RJ-45, 8 way, 0.3 meters, data cable)

RoHS Certification of Compliance

The BotBlox PoEBlox complies with the RoHS (Restriction of Hazardous Substances Directive) Certificate of Compliance.

HARDWARE INTERFACE

Board Map

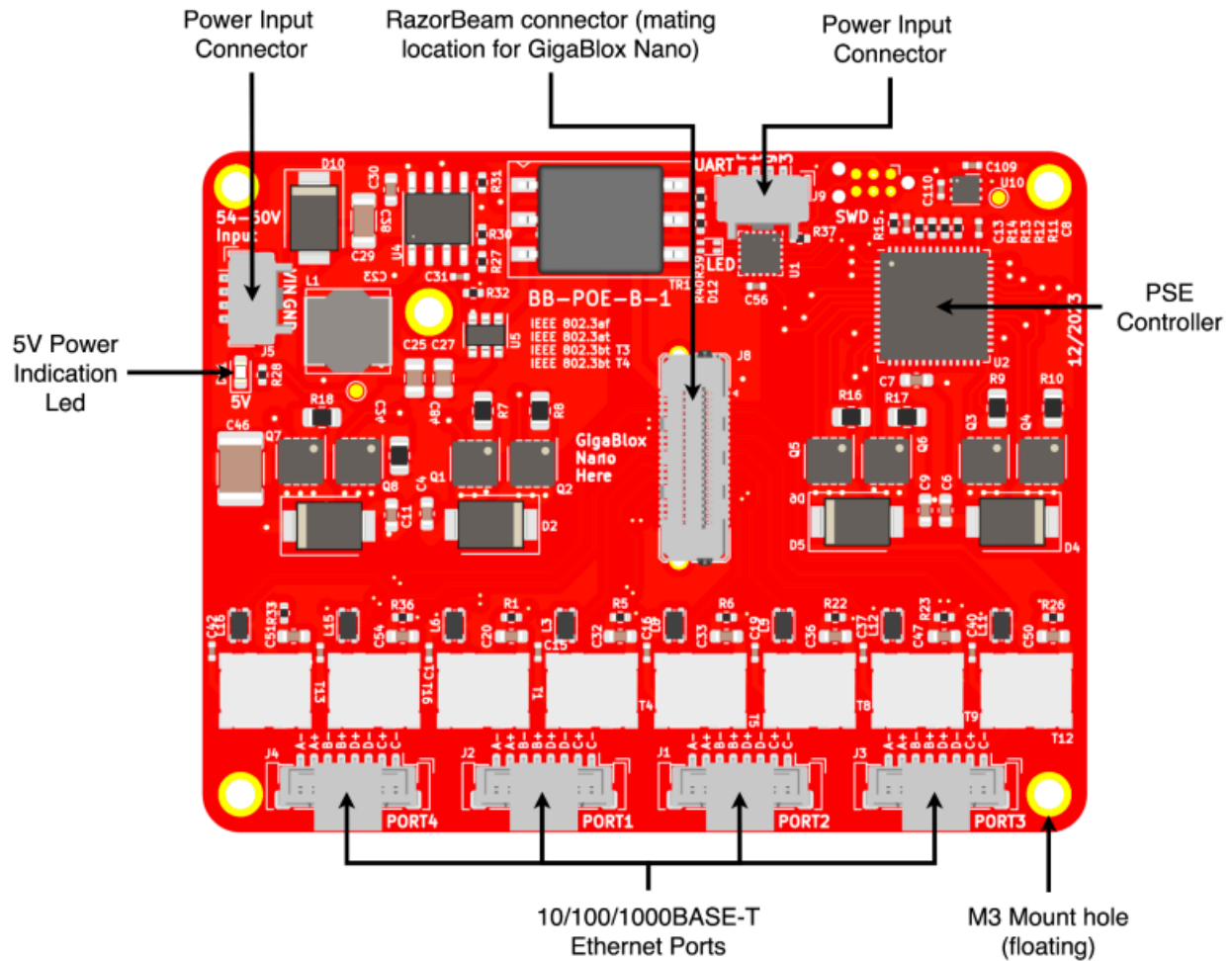

CONNECTORS AND PINOUTS

Voltage Input The right connector is the voltage input terminal. A four pin connector is used to supply maximum 360W (two wires per power rail). The voltage input has the following features:

- Voltage input can range from 48 to 57V
- Maximum allowable voltage of 70V Transient voltage protection above 66.3V
- Reverse polarity protection

The pinout of the voltage input connector is shown in figure below.

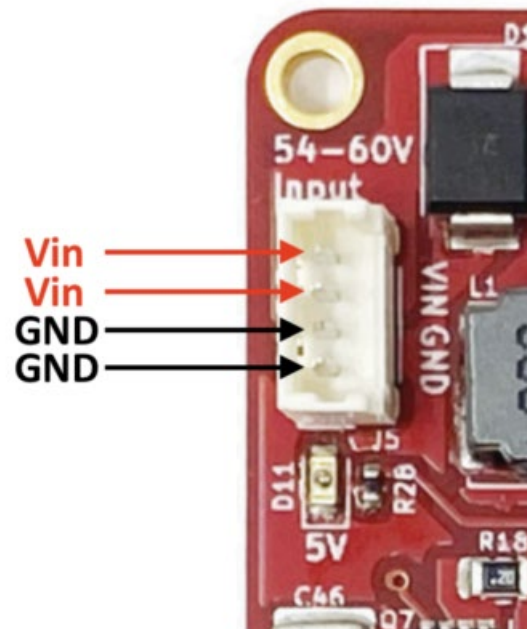

Voltage input header pinout

Connector on board	Mating header	Crimp used	Wire used
530470410	05102103400	500798000	UL1061, 28AWG

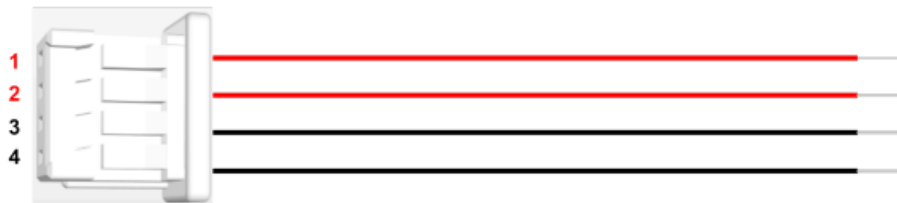

Voltage input cable pinout (red = Vin (V+), black = GND)

RazorBeam Connector

RazorBeam connector on PoEBlox allows it to be connected to GigaBlox Nano to form a complete PoE switch system with 4 port gigabit ethernet switch and PoE capability upto 90W per port.



RazorBeam connector on PoEBlox. This is where GigaBlox Nano (BB-GGN-A-1) mounts to PoEBlox

Ethernet Ports

PoEBlox uses four Molex PicoBlade connectors for the gigabit ethernet ports. These connectors can both provide up to 90W of power on each port (360W total), and can transmit/receive data at 1Gbps.

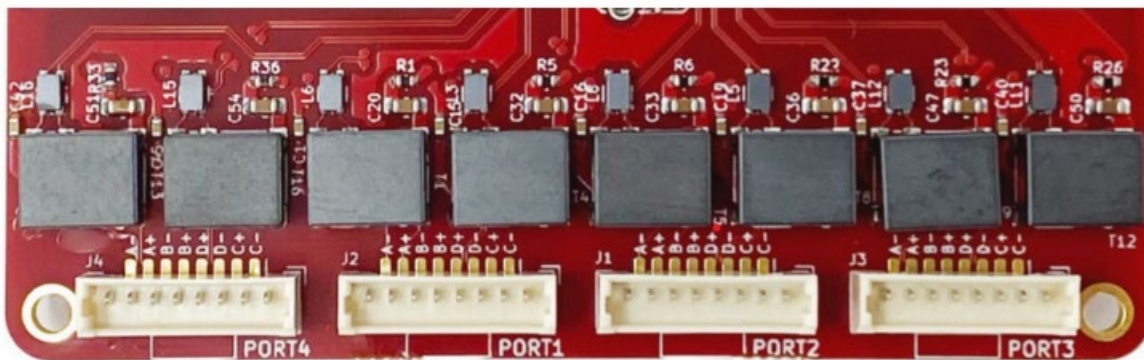

Molex PicoBlade Ports

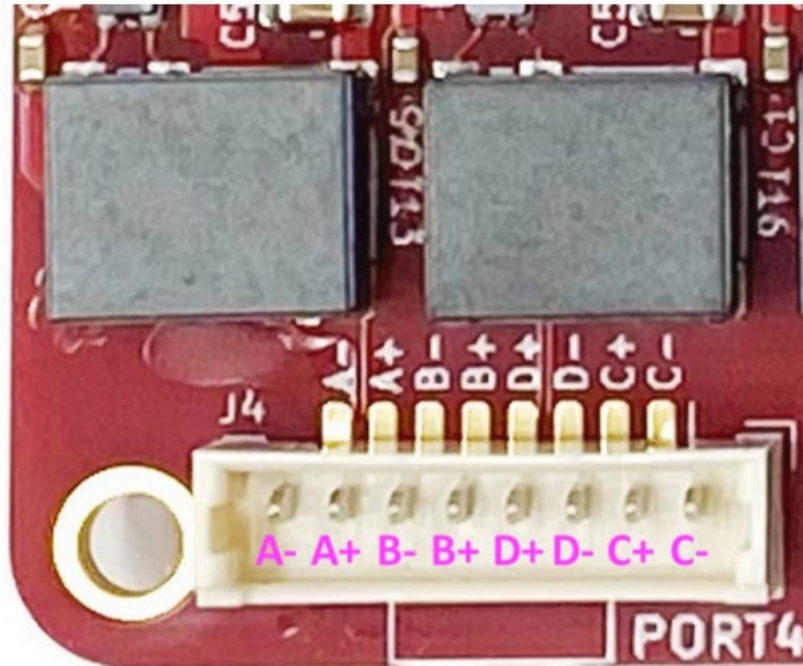

Ethernet pinout on Molex PicoBlade ports

The part numbers for the ethernet port connectors are detailed in table below.

Connector on board	Mating header	Crimp used	Wire used
520470810	0510210800	500798000	UL1061, 28AWG

Ethernet connector pinout and part numbers

8p Picoblade to RJ-45 300mm

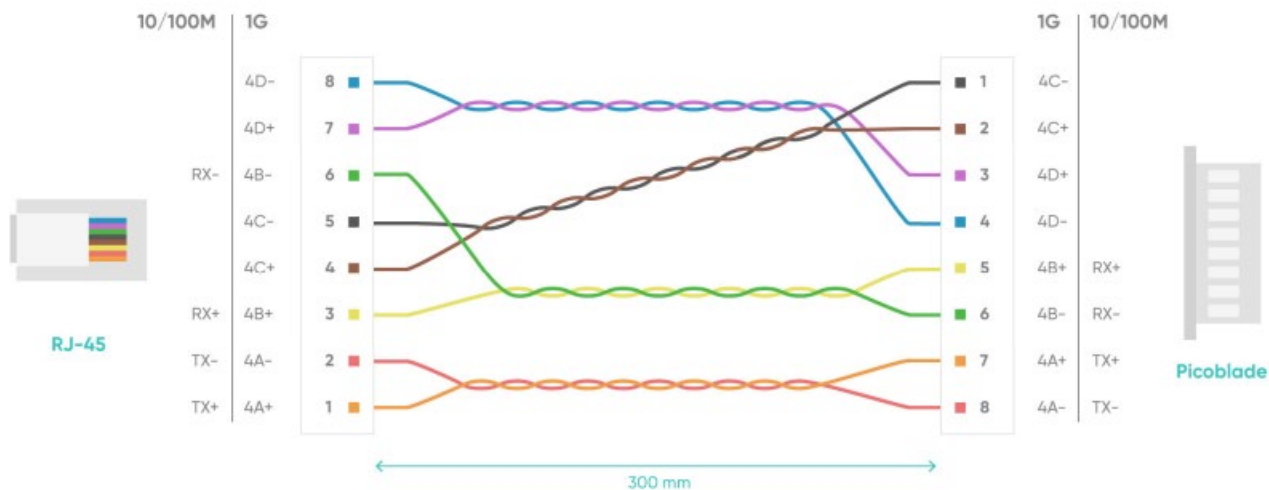

Ethernet cable pinout

UART Port

PoEBlox contains a 3.3V level UART port that connects to an onboard microcontroller for PSE management. Currently this functionality is unimplemented, but this connector is present on the board for future expansion.

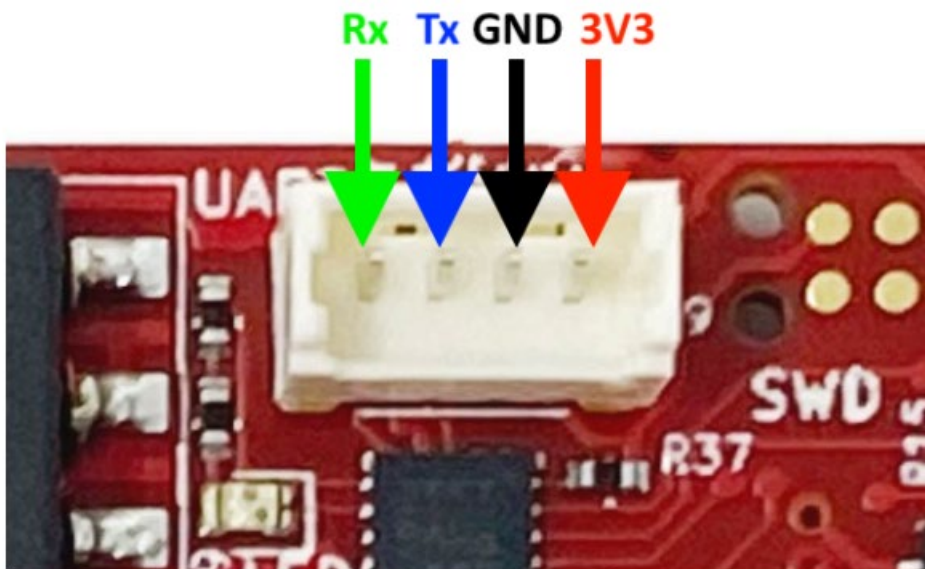

Pinout of the onboard UART port

Other Interfaces

LED's

There is only 1 LED on PoEBlox, that indicates the onboard 5V power regulation is functional.

Software Interfaces

UART

PoEBlox contains a microcontroller onboard that connects to the PSE management controller. This allows the microcontroller to read and write the onboard registers of the PSE controller and send these out via a UART port. At present this functionality is unimplemented, but it is included for future expansion.

SWD

There is an SWD port onboard that allows firmware to be uploaded to the microcontroller, shown in figure below.

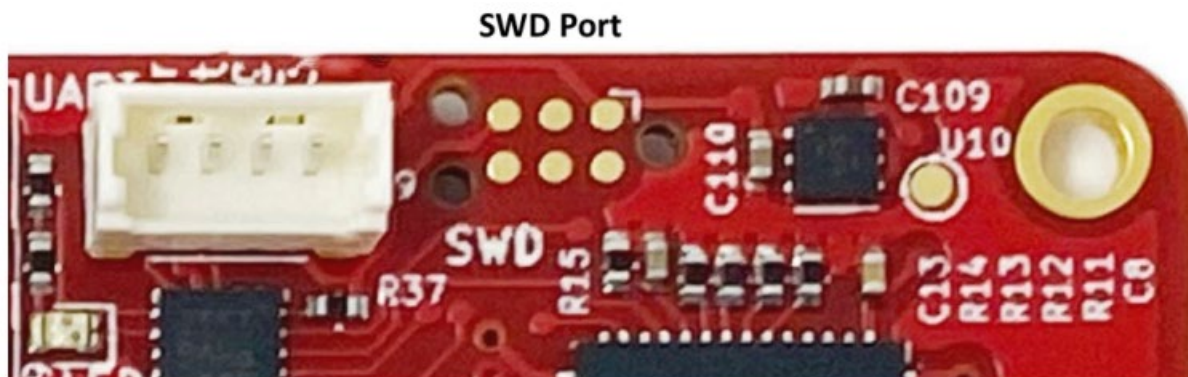

The SWD port on PoEBlox on a six pin tag-connect compatible header

Device Configuration

Auto Mode

By default, PoEBlox runs in Auto mode. The port performs detection and classification (if valid detection occurs) continuously. Registers are updated each time a detection or classification occurs. The port power is automatically turned on based on the Power Allocation settings in register 0x29 if a valid classification is measured.

Semiauto Mode

The port performs detection and classification (if valid detection occurs) continuously. Registers are updated each time a detection or classification occurs. The port power is not automatically turned on. Configuring PoEBlox in this mode requires custom firmware.

Manual/Diagnostic Mode

The use of this mode is intended for system diagnostic purposes only in the event that ports cannot be powered in accordance with the IEEE 802.3bt standard from Semiauto or Auto modes. The port performs the functions as configured in the registers. There is no automatic state change. Singular detection and classification measurements will be performed when commanded. Ports will be turned on immediately after a Power Enable command without any detection or classification measurements. Even though multiple classification events may be provided, the port voltage will reset immediately after the last finger, resetting the PD. Configuring PoEBlox in this mode requires custom firmware.

Device Characteristics

Operating Conditions

Absolute Maximum Ratings

Operating beyond these ranges will reduce the lifetime of the device.

Voltage Input Maximum	70V
PoE power Delivery (per port)	90W
Storage Temperature	-55°C to +125°C
Operating Temperature	-40°C to +85°C