

# RADIATION TOLERANT MEDIA CONVERTERS

PDS-282



## DESCRIPTION

New platforms and system upgrades are most likely required to endure a nuclear even or radiation from space and or high altitude. Our CTF-QUAD integrated products for 850nm and 1300nm multi-mode optics are completely tested along with the electronics for use in these systems. Any customers involved in high altitude platforms, space applications, or any application involved in warfare should take notice and be targets for our qualified technology. Along with qualification data in vibration, temperature, shock, and others, HSS had compelling value proposition for media conversion, high speed copper, and fiber optic product line.

Radiation Details	
LINAC	1.2 10 <sup>7</sup> -1.2 10 <sup>8</sup> rad (Si)/sec
GRF	3000-9000 rad (Si)
FBR	1.2 x 10 <sup>10</sup> - 1.2 x 10 <sup>11</sup> n/cm <sup>2</sup>

Full report available upon request

## WHAT WAS TESTED

- CTF-Quad electronics and optical sub assemblies were tested in the radiation environment
- Optical sub assemblies and electronics for 850nm multi-mode optics for up to 4.25Gbps signaling
- Optical sub assemblies and electronics for 1300nm (LED) multi-mode optics for speeds from 1 to 150Mbps



Part Number	Wavelength	Mode	Max Speed
CF-170900-000	850nm VCSEL	MM	up to 4.25 Gbps Tx - Support for pathological
CF-170900-001	850nm PIN + TIA	MM	up to 4.25 Gbps Rx Encoded
CF-170900-020	850nm PIN + TIA	MM	up to 4.25 Gbps Rx Pathological
CF-170900-024	1300nm LED	MM	up to 125Mbps Tx
CF-170900-025	1300nm Photodiode	MM	up to 125Mbps Rx
CF-170900-010	1310nm DFB Laser	SM	up to 2.5 Gbps Tx
CF-170900-011	1310nm Photodiode	SM	up to 2.5 Gbps Rx

# EXAMPLE COMPONENT

## CF-020010-348

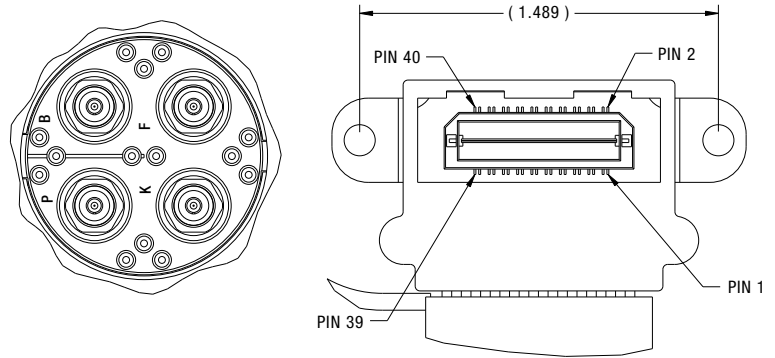
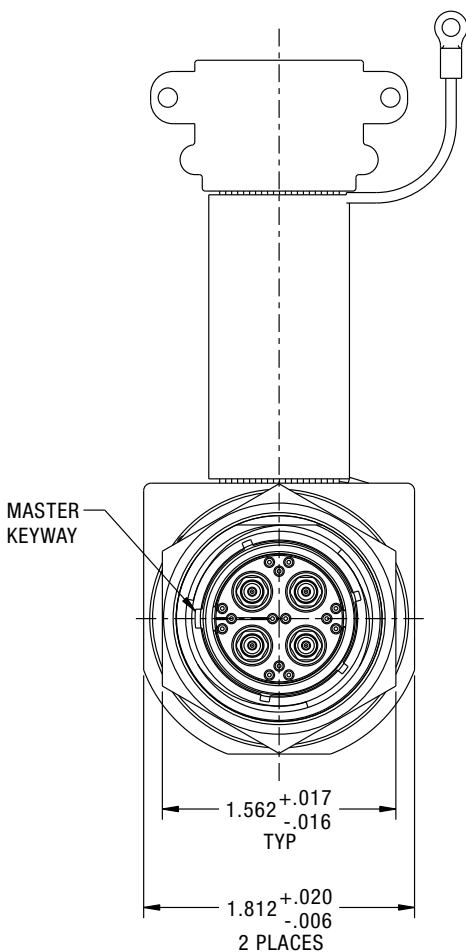
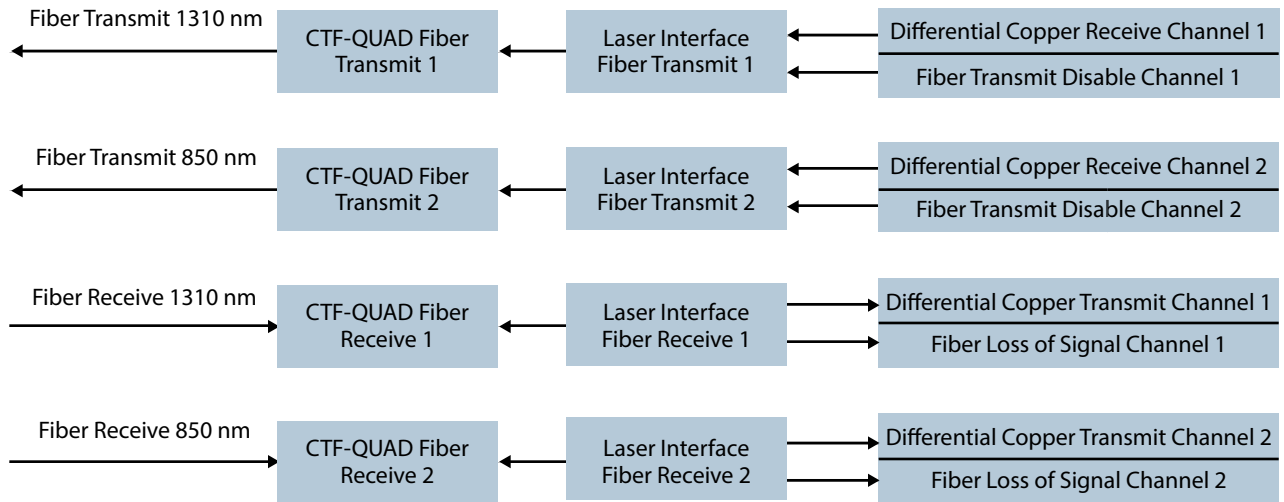

CAVITY ID	SIGNAL	DESCRIPTION	FIBER	INTERFACE
P	TX1	Transmit CH1 , Optical	MM 1310	100-BASE-FX
B	RX1	Receive CH1 , Optical		
K	TX2	Transmit CH2 , Optical	MM 850	3.125 Gbps Video
F	RX2	Receive CH2 , Optical		

# HOW TO CONFIGURE A PLUG

## CTF-QUAD MATING PLUG

Ordering procedure is shown below using part number CTF-5P96A1-00N  
(kit with connector and appropriate number of A801 cavity adapters)

1.	2.	3.	4.	5.	6.	7.
Connector Type	Material	Quadrax Contact	Finish	Shell Style	Shell Size - Insert Arrangement	Rotation
CTF	5	P	Z	6	A1	N

### 1. Connector Type

	Designates
CTF	Copper to Fiber Product Family

### 2. Select a Material

	Designates
5	Aluminum Shell
6	Composite Shell
8	Stainless Steel Shell

### 3. Quadrax Contact

	Designates
P	Quadrax Size 8 Contact Adapter for ARINC 801 Contact

### 4. Select a Finish

	Designates
T	Aluminum Durmalon
Z	Aluminum Black Zinc Nickel
F	Aluminum Electroless Nickel
M	Composite Electroless Nickel
W	Aluminum OD Cad
J	Composite OD Cad
L	Stainless Steel Electrodeposited Nickel
Y	Stainless Steel Passivated*

\*environmental only-not hermetic

### 5. Select a Shell Style

	Designates
0	Wall Mount
N	Wall Mount w/ Clinch Nuts
7	Jam Nut

Note: All with Stand-off

### 6. Select a Shell Size - Insert Arrangement

	Designates
A1	9-5
E2	17-52
F4	21-75
H6	23-6
J8	25-8

### 7. Select a Rotation

	Designates
N	Normal
A	
B	
C	
D	
E	