

SERIES **FIVE**

MAKE NO
COMPROMISES

Amphenol
Aerospace

UP TO
20%
SMALLER

UP TO
50%
LIGHTER

**Higher
Voltage
CAPABILITIES**

Than 38999 Series III



The World's Most Advanced
CONNECTOR

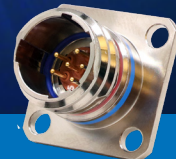

MILITARY • AEROSPACE • HARSH ENVIRONMENT • GENERAL DUTY

TABLE OF CONTENTS



MAKE NO
COMPROMISES

Table of Contents

About

Evolution	3
-----------------	---

Technical Data

Isolated Features	4-5
Small • Lighter • Superior	6
Size Comparison Chart	7
Size Comparison-Same insert diameter & density	8
Contact Ratings, Contacts, Sealing Plugs, Tools.	9
Voltage Rating and Test Data.....	10
Insert Availability and Identification.....	11-12
Insert Arrangements	13
Plating Options	14-15

Series Five Standard

How to Order	16
Keyway Rotations	17
Plug with Accessory S506.....	18
Plug with Integral Banding Platform S596	19
Wall Mount Receptacle S500	20
Wall Mount with Integral Banding S580.....	21
Wall Mount Receptacle with Clinch Nuts S510....	22
Wall Mount Double Flange Receptacle S540	23
Jam Nut Receptacle Accessory Thread S507	24
Jam Nut with Integral Banding Platform S587	25
Jam Nut Receptacle with Standoff S517	26
Reduced Flange Jam Nut Receptacle S598	27
Box Mounting Receptacle S502	28
Box Mounting Receptacle with Clinch Nuts S512	29
Line Mounting Receptacle S501	30
Jam Nut with Double Flange S547	31
Square Flange -Short Standoff & Clinch S541	32

Series Five Bulkhead Feed Through

How to Order	33
Bulkhead Feed-Through Wall Mount	34
Bulkhead Feed-Through Jam Nut	35
Series Five Protection Caps	
How to Order	36
Receptacle Protection Cap	37
Plug Protection Cap	38
Jam Nut Spanner Envelope.....	39

Series Five Hermetic

Hermetic Introduction	40
How to Order	41
Hermetic Jam Nut with Standoff.....	42
Hermetic Box Mount	43

Series Five Accessories

Series Five Mini-Band Termination	44
Assembly Instructions	45-46
Backshells Introduction.....	47
Backshells Material Finishes.....	48
Backshells	49-52
Adapters	53-56
Tie Wrap Backshell	57
Strain Relief Clamp	58-60
Grommet Nut.....	61
Alumalight	62-65
EMI/RFI Non-Environmental Strain Relief Low.....	66-67

Series Five PCB Contacts Information

Board Layout for PCB- Termination	68-72
Plating	
AP-93 Rating	73
About Amphenol.....	74



EVOLUTION

The MIL-DTL-38999 series of connectors was born in the 1960's to provide a ruggedized military solution featuring smaller contacts and higher density insert patterns than the already popular MIL-DTL-5015. In the decades since, D38999 connectors have increased in popularity and have become the standard in Mil-Spec connectors for military and aerospace applications.



1964

MIL-DTL-38999
Series II



1966

MIL-DTL-38999
Series I



1976

MIL-DTL-38999
Series III

Along the way, continuous evolution has brought about new shell styles, new coupling methods, new derivatives, and new capabilities, all while remaining as popular as ever. Amphenol's new Series Five connector is the next evolutionary step in that impressive lineage, combining all of the capabilities of the traditional 38999 style connector in a lighter, smaller, and more compact package to support the aerospace industry's ever-changing demands.

2021

SERIES FIVE

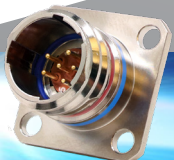

SERIES FIVE

MAKE NO COMPROMISES

38999-QUALIFIED INSULATOR

NO DIELECTRIC BOND JOINT

TRIPLE WIRE SEAL

AS39029-QUALIFIED GOLD-PLATED CONTACTS

FULL METAL CLIP CONTACT RETENTION

STANDARD ACCESSORY THREAD

RADIAL INTERFACIAL SEAL

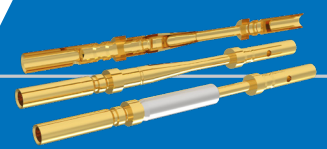
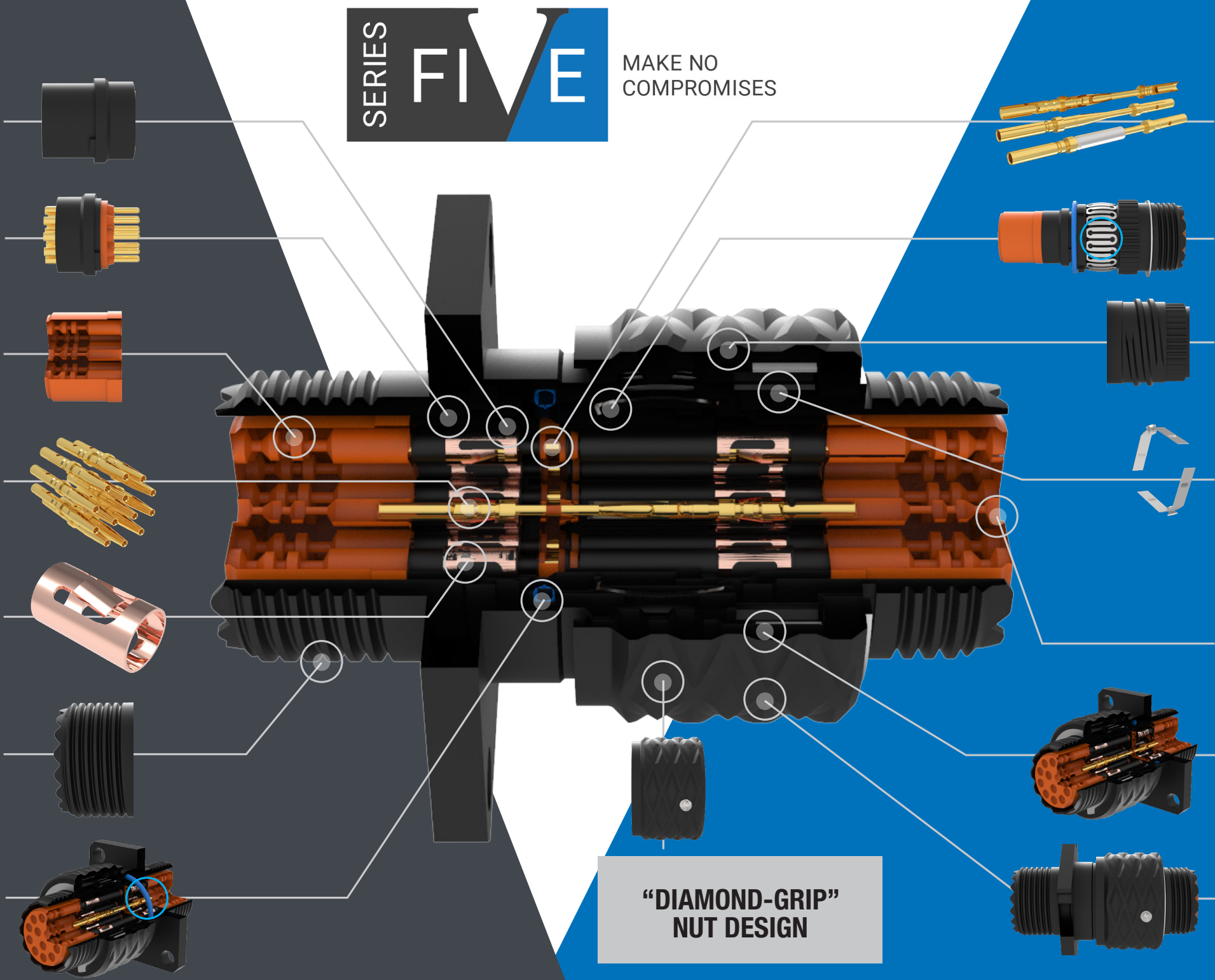

SCOOP PROOF

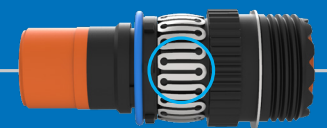

38999-QUALIFIED EMI SPRING

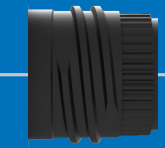

NO-MESS DRY FILM THREAD LUBRICANT



OPTIMIZED RATCHETING TORQUE

“DIAMOND-GRIP” NUT DESIGN

NO “BIRD BATH”

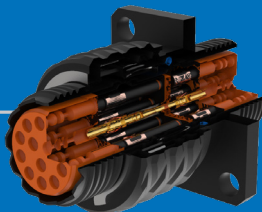

“NO-SLOP” TOLERANCE INTERFACE



QUICK COUPLING DOUBLE START THREAD

SMALLER • LIGHTER • SUPERIOR

SIZE COMPARISON USING SHELLS WITH THE SAME CONTACT COUNT



SERIES FIVE

2M805

D38999, SERIES III

25 - 50% LIGHTER



SERIES FIVE

2M805

D38999, SERIES III

PLUG WEIGHTS*

Shell Size	Plug Weights (oz.)		
	38999 Series III Plug	Series Five Plug	Weight Savings
Size 8	0.463	0.244	47%
Size 10	0.639	0.336	47%
Size 12	0.847	0.556	34%
Size 14	1.318	0.716	46%

*Corresponding 22D insert arrangement, with socket contacts included

WALL MOUNT RECEPTACLE WEIGHTS*

Shell Size	Receptacle Weights (oz.)		
	38999 Series III Wall Mount	Series Five Wall Mount	Weight Savings
Size 8	0.325	0.188	42%
Size 10	0.363	0.273	25%
Size 12	0.486	0.371	24%
Size 14	0.646	0.490	24%

*Corresponding 22D insert arrangement, with pin contacts included

JAM NUT RECEPTACLE PIN WEIGHTS*

Shell Size	Series III Jam Nut	S5 Jam Nut w/ Banding	Weight Savings
Size 8	0.441	0.268	39%
Size 10	0.593	0.353	40%
Size 12	0.772	0.450	41%
Size 14	0.984	0.570	42%

JAM NUT RECEPTACLE SOCKETS WEIGHTS*

Shell Size	Series III Jam Nut	S5 Jam Nut w/ Banding	Weight Savings
Size 8	0.504	0.285	43%
Size 10	0.726	0.378	48%
Size 12	0.988	0.499	49%
Size 14	1.328	0.649	51%



SERIES FIVE

Weight Comparison Chart

Weight (oz.)	Shell Type	SERIES FIVE		D38999, Series III			Weight Savings		
		Aluminum	St. Steel	Aluminum	St. Steel	Composite	S5 Alum vs SIII Alum	S5 Steel vs SIII Steel	S5 Alum vs SIII Comp
8-35 (A35)	Plug w. Sockets	0.250	0.496	0.463	1.136	0.299	46%	56%	16%
	Wall Mnt w. Pins	0.185	0.500	0.325	0.722	0.259	43%	31%	28%
8-98 (A98)	Plug w. Sockets	0.249	0.495	0.462	1.130	0.234	46%	56%	-6%
	Wall Mnt w. Pins	0.184	0.499	0.250	0.722	0.166	26%	31%	-11%
10-35 (B35)	Plug w. Sockets	0.346	0.710	0.639	1.381	0.458	46%	49%	25%
	Wall Mnt w. Pins	0.270	0.619	0.363	0.949	0.275	26%	35%	2%
10-98 (B98)	Plug w. Sockets	0.339	0.703	0.628	1.362	0.446	46%	48%	24%
	Wall Mnt w. Pins	0.266	0.614	0.363	0.949	0.275	27%	35%	4%
12-8 (C8)	Plug w. Sockets	0.541	0.984	0.973	1.984	0.595	44%	50%	9%
	Wall Mnt w. Pins	0.363	0.792	0.480	1.210	0.370	24%	35%	2%
12-35 (C35)	Plug w. Sockets	0.566	1.009	0.847	2.027	0.653	33%	50%	13%
	Wall Mnt w. Pins	0.371	0.800	0.486	1.216	0.376	24%	34%	1%
12-98 (C98)	Plug w. Sockets	0.554	0.997	0.986	1.997	0.716	44%	50%	23%
	Wall Mnt w. Pins	0.363	0.792	0.486	1.216	0.376	25%	35%	4%
14-5 (D5)	Plug w. Sockets	0.651	1.168	1.172	2.546	0.847	44%	54%	23%
	Wall Mnt w. Pins	0.451	0.935	0.635	1.531	0.503	29%	39%	10%
14-18 (D18)	Plug w. Sockets	0.700	1.218	1.274	2.581	0.821	45%	53%	15%
	Wall Mnt w. Pins	0.482	0.967	0.776	1.546	0.643	38%	37%	25%
14-35 (D35)	Plug w. Sockets	0.713	1.230	1.318	2.626	1.000	46%	53%	29%
	Wall Mnt w. Pins	0.490	0.974	0.646	1.542	0.514	24%	37%	5%

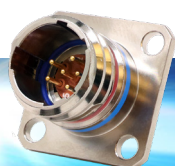

SERIES FIVE

Size Comparison - Same insert diameter & density

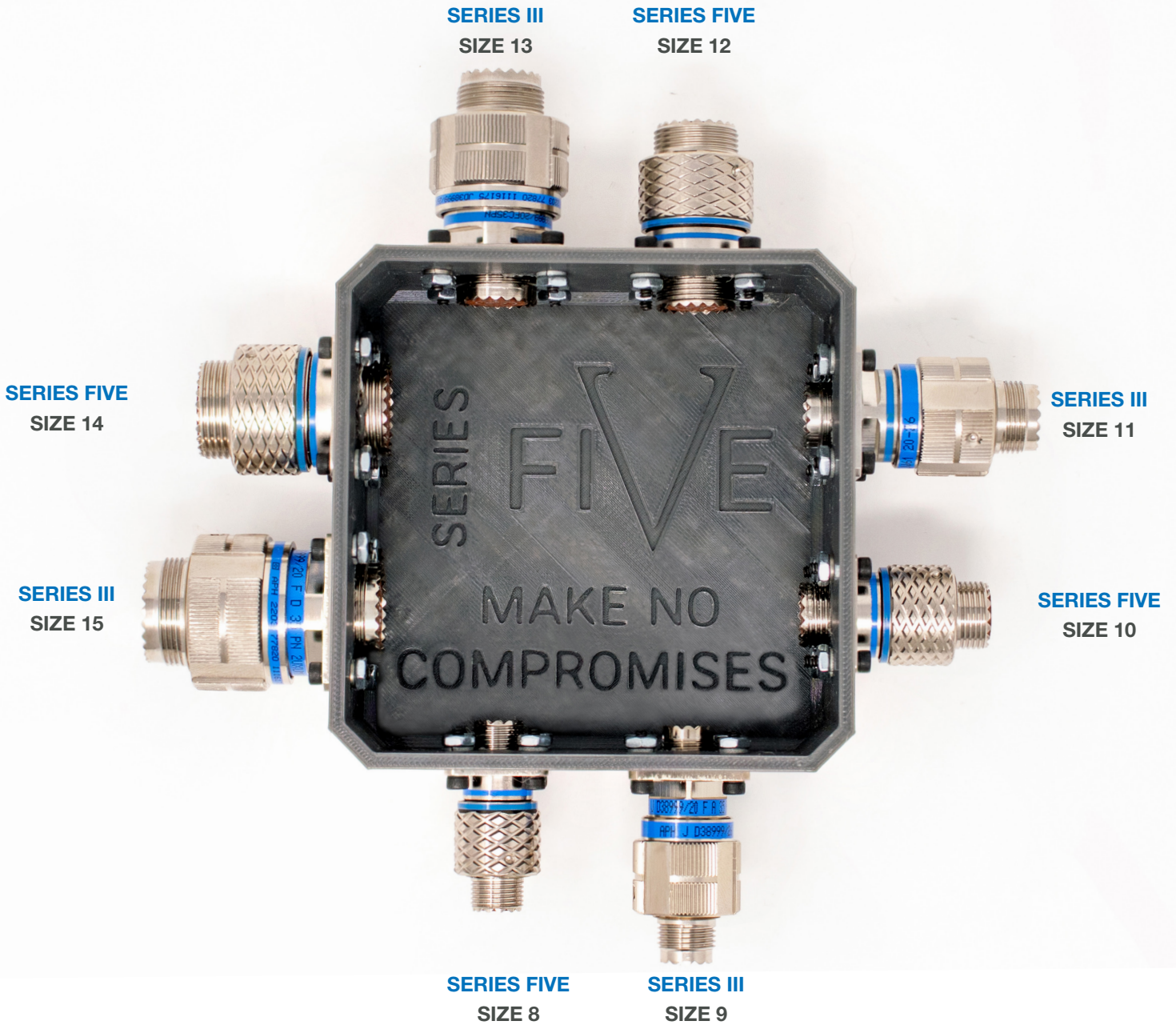

SAME INSERT



SERIES FIVE

Contact Ratings, Contacts, Sealing Plugs, and Crimping Tools

SERIES FIVE CONTACT RATING

Contact Size	Test Current (Amps)		Maximum Millivolt Drop Crimp*	Current with High Current Pins (HCP)
	Crimp			
22D	5	3	73	8
20	7.5	5	55	11
16	13	10	49	16
12	23	17	42	25

*When tested using silver plated wire.

Contact Size	Crimp Well Data	
	Well Diameter	Normal Well Depth
22D	.0345 ± .0010	.141
20	.047 ± .001	.209
16	.067 ± .001	.209
12	.100 ± .002	.209

SERIES FIVE CRIMP CONTACTS

Contact Size	Pins Military No.	Socket Military No.
22D	M39029/58-360	M39029/57-354
20	M39029/58-363	M39029/57-357
16	M39029/58-364	M39029/57-358
12	M39029/58-365	M39029/57-359

Above part numbers include standard finish designation - gold plating over suitable underplate in accordance with MIL-DTL-39029. For other finishes, consult Amphenol Aerospace.

SERIES FIVE INSERTION & REMOVAL TOOLS

Contact Size	Pins Military No.	Color Code
22D	M81969/14-01*	(Green) White
20	M81969/14-10*	(Red) Orange
16	M81969/14-03*	(Blue) White
12	M81969/14-04*	(Yellow) White

*Double ended insertion/removal tool

SERIES FIVE CRIMP TOOLS

Contact Size	Pins Military No.	Socket Military No.
22D Socket	M22520/2-01 M22520/7-01	M22520/2-06 M22520/7-06
22D Pin	M22520/2-01 M22520/7-01	M22520/2-09 M22520/7-04
20 Pin and Socket	M22520/1-01 M22520/2-01 M22520/7-01	M22520/1-04 M22520/2-10 M22520/7-08
16 Pin and Socket	M22520/1-01 M22520/7-01	M22520/1-04 M22520/7-04
12 Pin and Socket	M22520/1-01	M22520/1-04

Standard Amphenol Contact AWG Ranges		
Contact Size	Max	Min
22D	22	28
20	20	24
16	16	20
12 (Power)	12	14
8 (Power)	8	10*

*with crimp reducing adapter/bushing AS39029/112

SERIES FIVE SEALING PLUGS

Contact Size	Commercial No.	Military No.
22D	10-405996-222	MS27488-22-2
20	10-405996-202	MS27488-20-2
16	10-405996-162	MS27488-16-2
12	10-405996-122	MS27488-12-2

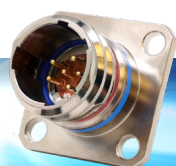

SERIES FIVE

Voltage Rating and Test Data

VOLTAGE COMPARISON CHART

D38999 Series III				Series Five								
Service Rating	Suggested Oper. Voltage (D38999)- Sea Level		Test Voltage (Unmated)	Service Rating	Qualification Voltage (Mated)				Suggested Oper. Voltage Sea Level (Unmated)		Test Voltage (Unmated) (VRMS)	Insulation Resistance
	AC (RMS)	DC	Sea Level		Sea Level	50,000 FT.	75,000 FT.	100,000 FT.	AC (RMS)	DC	Sea Level	
N	300	450	1000	N	1000	400	260	200	300	450	1000	5,000 MΩ
M	400	500	1300	X	2500	1800	1200	1200	825	1000	2000	5,000 MΩ
I	600	850	1800	Y	3000	2500	2000	1800	1000	1300	2500	5,000 MΩ
II	900	1250	2300	Z	3000	2500	2000	1800	1150	1500	2500	5,000 MΩ

Please note that the establishment of electrical safety factors is left entirely in the designer's hands, since they are in the best position to know what peak voltage, switching surges, transients, etc. can be expected in particular circuit.

TYPICAL SHIELDING EFFECTIVENESS TEST DATA

EMI/EMP SHIELDING EFFECTIVENESS dB TESTING BY TRIAXIAL METHOD

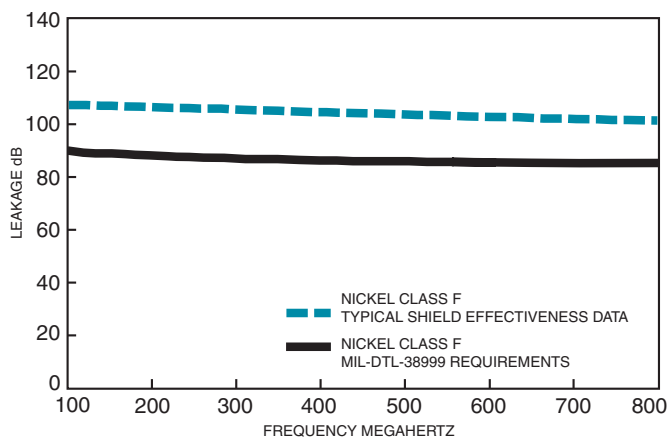

TYPICAL SHIELDING EFFECTIVENESS TEST DATA

EMI/EMP SHIELDING EFFECTIVENESS dB TESTING BY MODE STIRRING METHOD

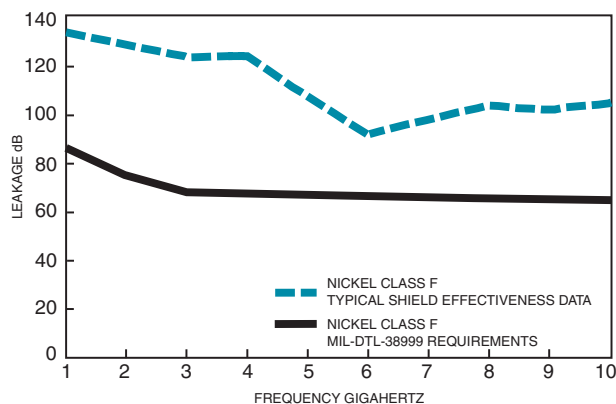

VIBRATION CRITERIA

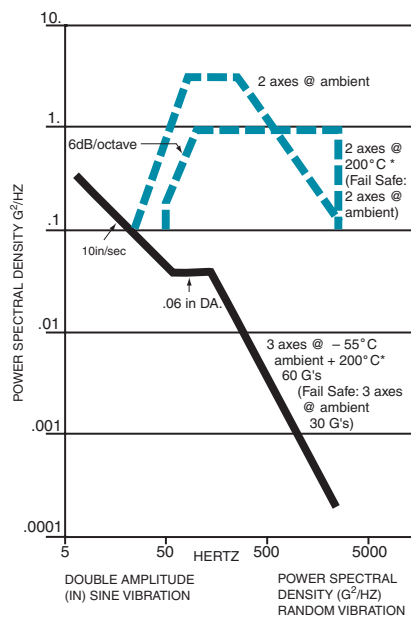

SERIES FIVE

Insert Availability and Identification Chart



Series Five	Box Mount	Total Contacts	Service Rating	Contact Size					
				23	22D	20	16	12	8 Twinax
8-5		1	Ground						1
8-35	√	6	X		6				
8-98	√	3	Y			3			
10-2	√	2	Y				2		
10-4	√	4	Y			4			
10-5	√	5	Y			5			
10-35	√	13	X		13				
10-98	√	6	Y			6			
10-99	√	7	Y			7			
12-3	√	3	Z				3		
12-4	√	4	Y				4		
12-8	√	8	Y			8			
12-35	√	22	X		22				
12-98	√	10	Y			10			
14-4		4	Y					4	
14-5	√	5	Z				5		
14-15		15	Y			14	1		
14-18	√	18	Y			18			
14-19	√	19	Y			19			
14-35	√	37	X		37				
14-68		8	Y				8		
14-97	√	12	Y			8	4		
16-6	√	6						6	
16-8	√	8					8		



*Note: Contact Amphenol factory for availability

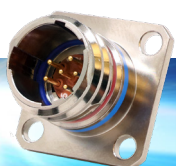

SERIES FIVE

Insert Availability and Identification Chart

Series Five	Box Mount	Total Contacts	Service Rating	Contact Size					
				23	22D	20	16	12	8 Twinax
16-13		13	Y				13		
16-26	√	26	Y			26			
16-35	√	55	X		55				
16-99	√	23	Y			21	2		
18-11	√	22	Z				11		
18-28	√	28	Y			26	2		
18-30	√	30	Y			29	1		
18-32	√	32	Y			32			
18-35	√	66	X		66				
18-68		18	Y				18		
18-96		9	Y					9	
20-16	√	16	Z				16		
20-35	√	79	X		79				
20-41	√	41	Y			41			
22-14		14	Y					14	
22-21	√	21	Z				21		
22-32	√	32	Y			32			
22-35	√	100	X		100				
22-55	√	55	Y			55			
24-4	√	56	Y			48	8		
24-19	√	19	Y					19	
24-24	√	24	Y				12	12	
24-29	√	29	Y				29		
24-35	√	128	X		128				
24-37	√	37	Y				37		
24-61	√	61	Y			61			

Shell Size & Insert Arrg. for:

	8-5	8-35	8-98	10-2	10-4	10-5	10-35	10-98	10-99	12-3
Service Rating	Ground	Y	N	Y	Y	Y	X	Y	Y	Z
Number of Contacts	1	6	3	2	4	5	13	6	7	3
Contact Size	8 Twinax	22D	20	16	20	20	22D	20	20	16

*Note: Contact Amphenol factory for availability



SERIES FIVE

Insert Arrangements

Front face of pin inserts illustrated

Shell Size &
Insert Arrg. for:

Series Five
Service Rating
Number of Contacts
Contact Size

12-4	12-8	12-35	12-98	14-4	14-5	14-15	14-18	14-19
Y	Y	X	Y	Y	Z	Y	Y	Y
4	8	22	10	4	5	14 1	18	19
16	20	22D	20	12	16	20 16	20	20

Shell Size &
Insert Arrg. for:

Series Five
Service Rating
Number of Contacts
Contact Size

14-35	14-68	14-97	16-6	16-8	16-26	16-35
X	Y	Y	Y	Y	Y	X
37	8	8 4	6	8	26	55
22D	16	20 16	12	16	20	22D

Shell Size &
Insert Arrg. for:

Series Five
Service Rating
Number of Contacts
Contact Size

16-99	18-11	18-28	18-30	18-32	18-35	18-68	18-96
Y	Z	Y	Y	Y	X	Y	Y
21 2	11	26 2	29 1	32	66	66	9
20 16	16	20 16	20 16	20	22D	22M	2

Shell Size &
Insert Arrg. for:

Series Five
Service Rating
Number of Contacts
Contact Size

20-16	20-35	20-41	22-14	22-21	22-32	22-35	22-55
Z	X	Y	Y	Z	Y	X	Y
16	79	41	14	21	32	100	55
16	22D	20	12	16	20	22D	20

Shell Size &
Insert Arrg. for:

Series Five
Service Rating
Number of Contacts
Contact Size

24-4	24-19	24-24	24-35	24-37	24-61
Y	Y	Y	X	Y	Y
48 8	19	12 12	128	37	61
20 16	12	16 12	22D	16	20

*Note: Contact Amphenol factory for availability



CONTACT LEGEND 12 16 20 22D 23

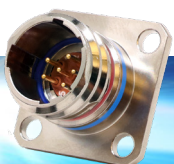

PLATING OFFERINGS - SERIES V



OLIVE DRAB CADMIUM			
Cost	\$	Salt Spray (Hrs)	500
Conductivity	◆◆◆	Toxicity	High
Corrosion Resistance	★ ★ ★	Scratch Resistance	✗
Temp Rating	175	Reflectivity	Low
AAO Code	DW	Gloss Unit	26
REACH/RoHS	NO	Color	
Legacy Applications			



AP-93*			
Cost	\$\$\$	Salt Spray (Hrs)	1000
Conductivity	◆◆◆◆	Toxicity	-
Corrosion Resistance	★★★★	Scratch Resistance	✗ ✗
Temp Rating	200	Reflectivity	High
AAO Code	DS	Gloss Unit	221
REACH/RoHS	YES	Color	
Extreme Harsh, Corrosive Environment, Space			



*See page 61



ELECTROLESS NICKEL			
Cost	\$	Salt Spray (Hrs)	48
Conductivity	◆◆◆◆	Toxicity	-
Corrosion Resistance	★	Scratch Resistance	✗✗✗
Temp Rating	200	Reflectivity	High
AAO Code	DR	Gloss Unit	153
REACH/RoHS	YES	Color	
Box Interiors, PCB Terminated			



PASSIVATED STAINLESS STEEL			
Cost	\$\$\$\$	Salt Spray (Hrs)	500
Conductivity	◆	Toxicity	-
Corrosion Resistance	★★★	Scratch Resistance	✗✗✗✗
Temp Rating	200	Reflectivity	High
AAO Code	RK	Gloss Unit	-
REACH/RoHS	YES	Color	
Radar System, Engines, Ground Vehicles			



BLACK ZINC NICKEL			
Cost	\$\$	Salt Spray (Hrs)	500
Conductivity	◆◆◆	Toxicity	-
Corrosion Resistance	★★★	Scratch Resistance	✗✗
Temp Rating	175	Reflectivity	Low
AAO Code	DZ	Gloss Unit	50
REACH/RoHS	YES	Color	
C4ISR			



MARINE BRONZE			
Cost	\$\$\$\$	Salt Spray (Hrs)	500
Conductivity	◆◆◆	Toxicity	-
Corrosion Resistance	★★★	Scratch Resistance	✗✗✗✗
Temp Rating	200	Reflectivity	High
AAO Code	RB	Gloss Unit	-
REACH/RoHS	YES	Color	
Shipboard Applications			



DURMALON (NICKEL-PTFE)			
Cost	\$\$\$	Salt Spray (Hrs)	500
Conductivity	◆◆◆	Toxicity	-
Corrosion Resistance	★★★	Scratch Resistance	✗✗✗✗
Temp Rating	175	Reflectivity	Medium
AAO Code	DT	Gloss Unit	100
REACH/RoHS	YES	Color	
Ground Vehicles Aircraft			



ANODIZED PLATING			
Cost	\$	Salt Spray (Hrs)	1000
Conductivity	-	Toxicity	-
Corrosion Resistance	★★★★	Scratch Resistance	✗✗✗
Temp Rating	200	Reflectivity	Low
AAO Code	RX	Gloss Unit	-
REACH/RoHS	YES	Color	
Military Shelter Non-conductive Applications			



PLATING OFFERINGS

STANDARD PLATING OFFERINGS						
Plating	Material	Commercial Service Class	Salt Spray	REACH/ RoHS	Temp Rating	Millivolt Drop
AP-93	Aluminum	DS	1,000	✓	200	1.0
Olive Drab Cadmium, Nickel Base - 500 hour	Aluminum	DW	500	No	175	3.0
Electroless Nickel	Aluminum	DR	48	✓	200	1.0
Electroless Nickel, Space Grade	Aluminum	DR*	48	✓	200	1.0
Black Zinc Nickel	Aluminum	DZ	500	✓	175	2.5
Durmalon (Nickel-PTFE)	Aluminum	DT	500	✓	175	2.5
Marine Bronze	Aluminum Bronze	RB	500	✓	200	5.0
Passivated Stainless Steel	Stainless Steel	RK	500	✓	200	10
Stainless Steel w. Nickel plate	Stainless Steel	RL	500	✓	200	1.0
Passivated Stainless Steel (Hermetic)	Stainless Steel	Y	500	✓	200	10
Electrolytic Nickel (Hermetic)	Stainless Steel	YN	48	✓	200	1.0



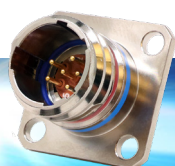

















*With (453) Mod Code



HOW TO ORDER: SERIES FIVE STANDARD

S506DS-14-35PN

For Hermetics, see page 36
For Bulkhead Feed Through, see page 29

1. Connector Type	2. Shell Style	3. Service Class	4. Shell Size - Insert Arrg.	5. Contact Type	6. Alternate Positions	7. Mod (Optional)																																				
S5	06	DS-	14-35	P	N	<p>(729) Hex Nut replacing the spanner nut (Jam Nut only)</p> <p>(453) Space Grade</p> <p>(HCP) High Current Pin (Increased Amperage)*</p> <p>(V25) PCB contacts installed, .250" stickout</p> <p>(V25AD) PCB contacts installed, .250" stickout w. alignment disk</p> <p>(V25T) PCB contacts installed, .250" stickout, pre-tinned</p> <p>(V25ADT) PCB contacts installed, .250" stickout, pre-tinned, w. alignment disk</p> <p>* See page 8 for current rating Contact factory for more options & custom solutions</p>																																				
<p>1. Connector Type</p> <p>S5 Series Five</p> <p>PS5 Series Five with Potting</p>																																										
<p>2. Shell Style*</p> <table border="1"> <tr> <td>06</td> <td>Straight Plug pg 16</td> <td>07</td> <td>Jam Nut with Accessory Thread pg 22</td> </tr> <tr> <td>96</td> <td>Plug with Integral Banding Platform pg 17</td> <td>87</td> <td>Jam Nut with Integral Banding Platform pg 23</td> </tr> <tr> <td>00</td> <td>Wall Mount Receptacle pg 18</td> <td>17</td> <td>Jam Nut Receptacle with washout Standoff pg 24</td> </tr> <tr> <td>80</td> <td>Wall Mount with Inegral Banding Pg 19</td> <td>47</td> <td>Jam Nut with Double Flange</td> </tr> <tr> <td>10</td> <td>Wall Mount with Clinch Nuts pg 20</td> <td>98</td> <td>Jam Nut Receptacle with Standoff pg 25</td> </tr> <tr> <td>40</td> <td>Wall Mount with Double Flange pg 21</td> <td>02</td> <td>Box Mount Receptacle pg 26</td> </tr> <tr> <td>41</td> <td>Square Flange with Short Integrated standoffs & clinch nuts</td> <td>12</td> <td>Box Mount Receptacle-Clinch Nuts pg 27</td> </tr> <tr> <td></td> <td></td> <td>01</td> <td>Line Mounting Receptacle pg 28</td> </tr> <tr> <td></td> <td></td> <td>81</td> <td>Line Mount Receptacle with Integral Banding Platform</td> </tr> </table> <p>*Other shell styles available consult Amphenol for more information</p>							06	Straight Plug pg 16	07	Jam Nut with Accessory Thread pg 22	96	Plug with Integral Banding Platform pg 17	87	Jam Nut with Integral Banding Platform pg 23	00	Wall Mount Receptacle pg 18	17	Jam Nut Receptacle with washout Standoff pg 24	80	Wall Mount with Inegral Banding Pg 19	47	Jam Nut with Double Flange	10	Wall Mount with Clinch Nuts pg 20	98	Jam Nut Receptacle with Standoff pg 25	40	Wall Mount with Double Flange pg 21	02	Box Mount Receptacle pg 26	41	Square Flange with Short Integrated standoffs & clinch nuts	12	Box Mount Receptacle-Clinch Nuts pg 27			01	Line Mounting Receptacle pg 28			81	Line Mount Receptacle with Integral Banding Platform
06	Straight Plug pg 16	07	Jam Nut with Accessory Thread pg 22																																							
96	Plug with Integral Banding Platform pg 17	87	Jam Nut with Integral Banding Platform pg 23																																							
00	Wall Mount Receptacle pg 18	17	Jam Nut Receptacle with washout Standoff pg 24																																							
80	Wall Mount with Inegral Banding Pg 19	47	Jam Nut with Double Flange																																							
10	Wall Mount with Clinch Nuts pg 20	98	Jam Nut Receptacle with Standoff pg 25																																							
40	Wall Mount with Double Flange pg 21	02	Box Mount Receptacle pg 26																																							
41	Square Flange with Short Integrated standoffs & clinch nuts	12	Box Mount Receptacle-Clinch Nuts pg 27																																							
		01	Line Mounting Receptacle pg 28																																							
		81	Line Mount Receptacle with Integral Banding Platform																																							
<p>3. 175°C Service Class</p> <table border="1"> <tr> <td>DT-</td> <td>Durmalon </td> </tr> <tr> <td>DZ-</td> <td>Black Zinc-Nickel </td> </tr> <tr> <td>DW-</td> <td>Olive Drab Cadmium</td> </tr> </table> <p>See page 12-13 for plating options</p>							DT-	Durmalon 	DZ-	Black Zinc-Nickel 	DW-	Olive Drab Cadmium																														
DT-	Durmalon 																																									
DZ-	Black Zinc-Nickel 																																									
DW-	Olive Drab Cadmium																																									
<p>3. 200°C Service Class</p> <table border="1"> <tr> <td>DR-</td> <td>Electroless Nickel </td> </tr> <tr> <td>DS-</td> <td>AP-93* </td> </tr> <tr> <td>RK-</td> <td>Passivated Stainless Steel </td> </tr> <tr> <td>RS-</td> <td>Nickel plated, Stainless Steel </td> </tr> <tr> <td>RB-</td> <td>Aluminum Bronze </td> </tr> </table> <p>*See page 68 for more details on AP-93</p>							DR-	Electroless Nickel 	DS-	AP-93* 	RK-	Passivated Stainless Steel 	RS-	Nickel plated, Stainless Steel 	RB-	Aluminum Bronze 																										
DR-	Electroless Nickel 																																									
DS-	AP-93* 																																									
RK-	Passivated Stainless Steel 																																									
RS-	Nickel plated, Stainless Steel 																																									
RB-	Aluminum Bronze 																																									
<p>4. Shell Size/ Insert Arrangement</p> <p>See pages 10-11</p>																																										
<p>5. Contact Type</p> <table border="1"> <tr> <td>P</td> <td>* Pin (Recommended for receptacles)</td> </tr> <tr> <td>S</td> <td>Socket (Recommended for plugs)</td> </tr> </table> <p>*Scoop proof in this configuration</p>							P	* Pin (Recommended for receptacles)	S	Socket (Recommended for plugs)																																
P	* Pin (Recommended for receptacles)																																									
S	Socket (Recommended for plugs)																																									
<p>6. Alternate Positions</p> <table border="1"> <tr> <td>N</td> <td>Normal Rotation</td> </tr> <tr> <td>A</td> <td>A Rotation</td> </tr> <tr> <td>B</td> <td>B Rotation</td> </tr> <tr> <td>C</td> <td>C Rotation</td> </tr> <tr> <td>D</td> <td>D Rotation</td> </tr> <tr> <td>E</td> <td>E Rotation</td> </tr> </table> <p>See pages 15 for more information</p>							N	Normal Rotation	A	A Rotation	B	B Rotation	C	C Rotation	D	D Rotation	E	E Rotation																								
N	Normal Rotation																																									
A	A Rotation																																									
B	B Rotation																																									
C	C Rotation																																									
D	D Rotation																																									
E	E Rotation																																									



SERIES FIVE

Keyway Rotation Table

KEY/KEYWAY POSITION

A plug with a given rotation letter will mate with a receptacle with the same rotation letter. The angles for a given connector are the same whether it contains pins or sockets. Master key stays fixed, minor keys rotate. Inserts are not rotated in conjunction with the master key/keyway.



6. ALTERNATE KEYING					
Shell Size	Key & Keyway Arrangement Identification Letter	AR° or AP° BSC	BR° or BP° BSC	CR° or CP° BSC	DR° or DP° BSC
8	N	105	140	215	265
	A	102	132	248	320
	B	80	118	230	312
	C	35	140	205	275
	D	64	155	234	304
10 12 14	E	91	131	197	240
	N	95	141	208	236
	A	113	156	182	292
	B	90	145	195	252
	C	53	156	220	255
16 18 20	D	119	146	176	298
	E	51	141	184	242
	N*	80	142	196	293
	A	135	170	200	310
	B	49	169	200	244
22 24	C	66	140	200	257
	D	62	145	180	280
	E	79	153	197	272
	N*	80	142	196	293
	A	135	170	200	310

**RECEPTACLE
(FRONT FACE SHOWN)**

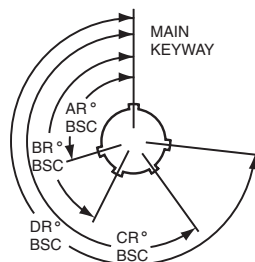

**PLUG
(FRONT FACE SHOWN)**

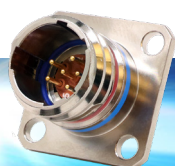
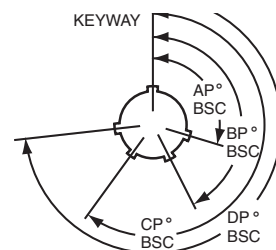

SERIES FIVE PLUG WITH ACCESSORY THREADS

S506

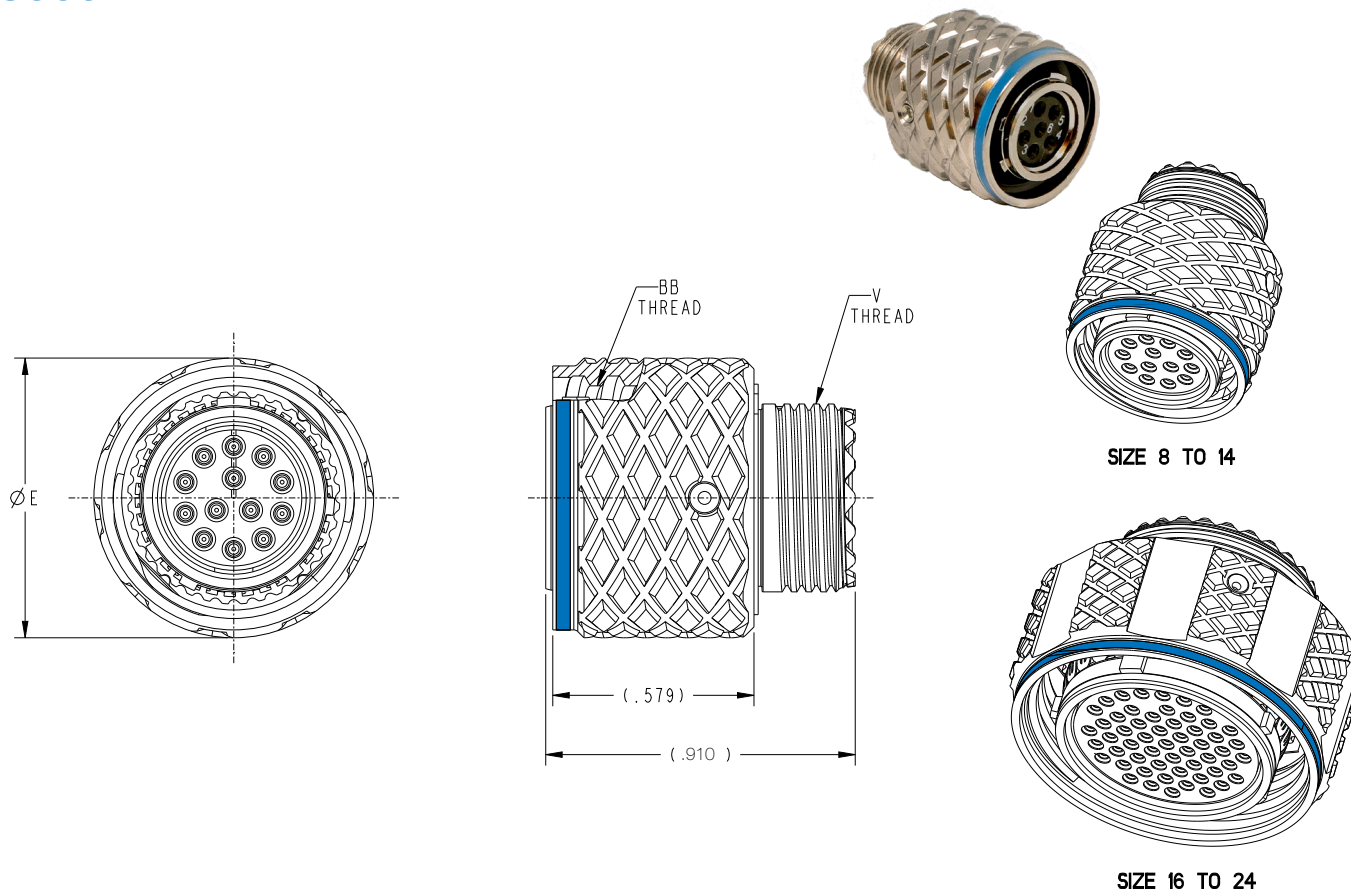

Shell Size	BB Thread	V Thread*	ØE ±.005
8	.5600 - .1P - .2L - DS	.4375 - 28 - UNEF	.682
10	.6800 - .1P - .2L - DS	.5625 - 24 - UNEF	.803
12	.8000 - .1P - .2L - DS	.6875 - 24 - UNEF	.923
14	.9200 - .1P - .2L - DS	.8125 - 20 - UNEF	1.043
16	1.1875 - .1P - .2L - DS	.9375 - 20 - UNEF	1.389
18	1.2500 - .1P - .2L - DS	1.0625 - 18 - UNEF	1.496
20	1.3750 - .1P - .2L - DS	1.1875 - 18 - UNEF	1.623
22	1.5000 - .1P - .2L - DS	1.3125 - 18 - UNEF	1.740
24	1.6250 - .1P - .2L - DS	1.4375 - 18 - UNEF	1.867

*Compatible with all D38999 Series II Accessories



SERIES FIVE PLUG WITH INTEGRAL BANDING PLATFORM

S596

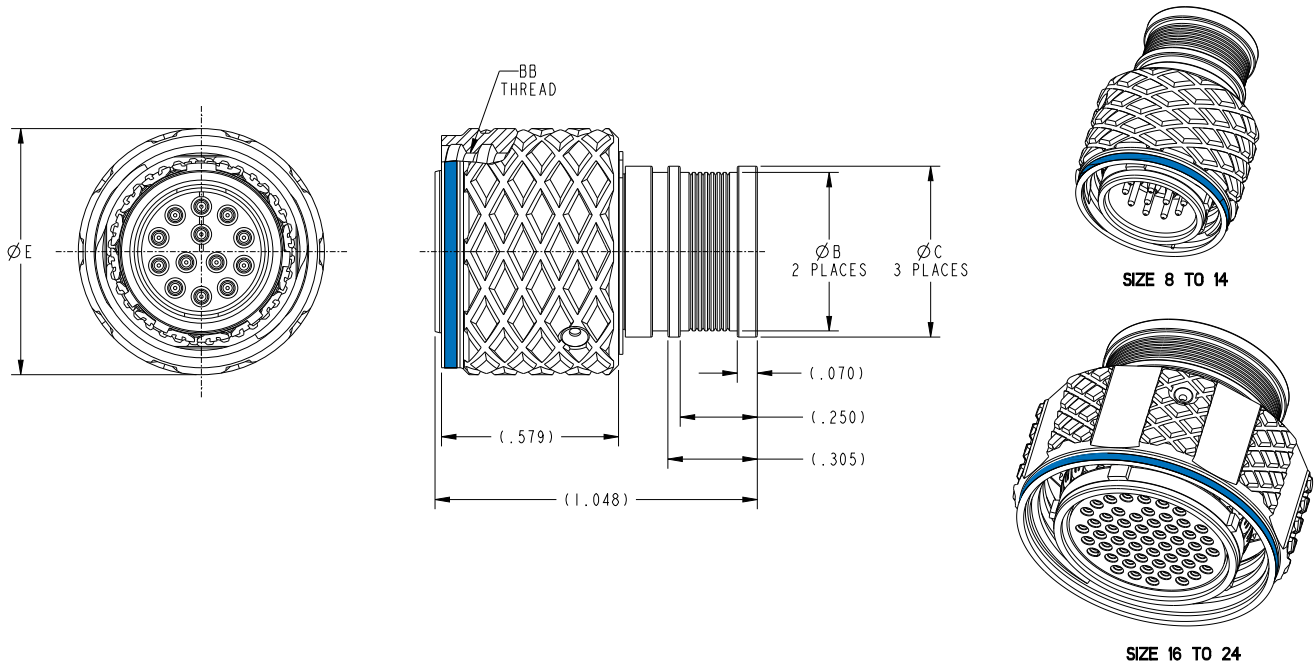

Shell Size	BB Thread	ØB ±.002	ØC ±.002	ØE ±.005
8	.5600 - .1P - .2L - DS	.397	.437	.682
10	.6800 - .1P - .2L - DS	.517	.557	.803
12	.8000 - .1P - .2L - DS	.637	.677	.923
14	.9200 - .1P - .2L - DS	.757	.797	1.043
16	1.1875 - .1P - .2L - DS	.877	.917	1.389
18	1.2500 - .1P - .2L - DS	.997	1.037	1.496
20	1.3750 - .1P - .2L - DS	1.117	1.157	1.623
22	1.5000 - .1P - .2L - DS	1.247	1.287	1.740
24	1.6250 - .1P - .2L - DS	1.367	1.407	1.867

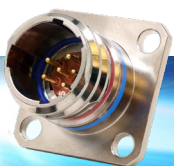

SERIES FIVE WALL MOUNTING RECEPTACLE

S500

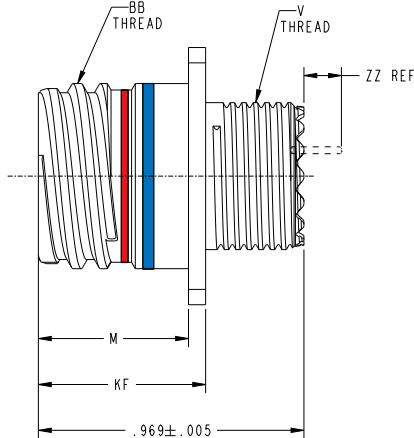
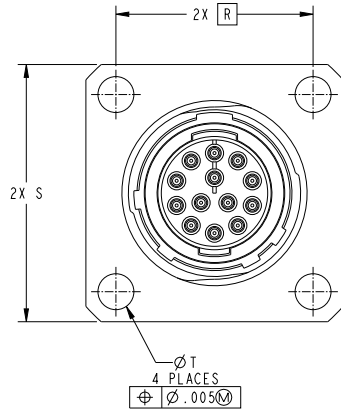

PANEL HOLE DIMENSIONS

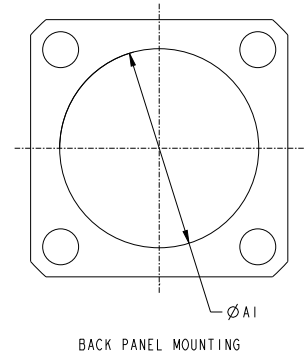

BACK PANEL MOUNTING

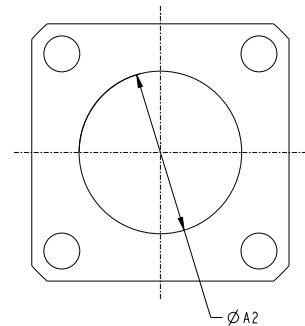

FRONT PANEL MOUNTING

Shell Size	BB Thread	V Thread*	(ØA1)	(ØA2)	M ±.003	R	S ±.012	ØT ±.008	KF ±.003	(ZZ)**
8	.5600 - .1P - .2L - DS	.4375 - 28 - UNEF	.606	.468	.5475	.594	.815	.128	.613	.250
10	.6800 - .1P - .2L - DS	.5625 - 24 - UNEF	.726	.593	.5475	.719	.941	.128	.613	.250
12	.8000 - .1P - .2L - DS	.6875 - 24 - UNEF	.846	.718	.5475	.812	1.034	.128	.613	.250
14	.9200 - .1P - .2L - DS	.8125 - 20 - UNEF	.966	.843	.5475	.906	1.128	.128	.613	.250
16	1.1875 - .1P - .2L - DS	.9375 - 20 - UNEF	1.230	.967	.5475	.969	1.222	.128	.651	.651
18	1.2500 - .1P - .2L - DS	1.0625 - 18 - UNEF	1.290	1.085	.5475	1.062	1.315	.128	.651	.651
20	1.3750 - .1P - .2L - DS	1.1875 - 18 - UNEF	1.420	1.209	.5475	1.156	1.441	.128	.651	.651
22	1.5000 - .1P - .2L - DS	1.3125 - 18 - UNEF	1.540	1.334	.5475	1.250	1.565	.154	.651	.651
24	1.6250 - .1P - .2L - DS	1.4375 - 18 - UNEF	1.660	1.459	.5475	1.375	1.691	.154	.651	.651

*Compatible with all D38999 Series II Accessories

**PCB Mod Codes Only



SERIES FIVE WALL MOUNTING RECEPTACLE WITH INTEGRAL BANDING PLATFORM

S580

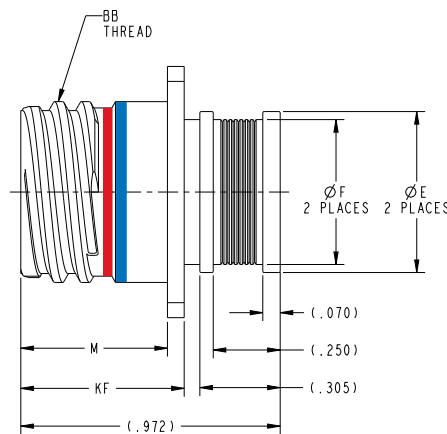
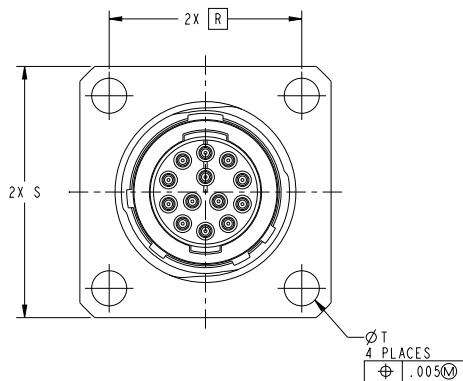

PANEL HOLE DIMENSIONS

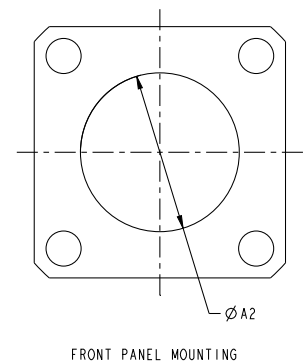
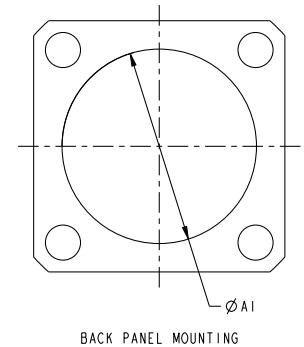

Shell Size	BB Thread	(ØA1)	(ØA2)	ØE ±.002	ØF ±.002	M ±.0030	R	S ±.012	ØT ±.008	KF ±.003
8	.5600 - .1P - .2L - DS	.606	.530	.483	.423	.5475	.594	.815	.128	.613
10	.6800 - .1P - .2L - DS	.726	.651	.604	.544	.5475	.719	.941	.128	.613
12	.8000 - .1P - .2L - DS	.846	.776	.729	.669	.5475	.812	1.034	.128	.613
14	.9200 - .1P - .2L - DS	.966	.910	.863	.803	.5475	.906	1.128	.128	.613
16	1.1875 - .1P - .2L - DS	1.230	1.025	.978	.918	.5475	.969	1.222	.128	.651
18	1.2500 - .1P - .2L - DS	1.290	1.143	1.096	1.036	.5475	1.062	1.315	.128	.651
20	1.3750 - .1P - .2L - DS	1.420	1.267	1.220	1.160	.5475	1.156	1.441	.128	.651
22	1.5000 - .1P - .2L - DS	1.540	1.392	1.345	1.285	.5475	1.250	1.565	.154	.651
24	1.6250 - .1P - .2L - DS	1.660	1.517	1.470	1.410	.5475	1.375	1.691	.154	.651

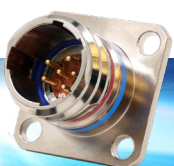

SERIES FIVE WALL MOUNTING RECEPTACLE CLINCH NUTS

S510

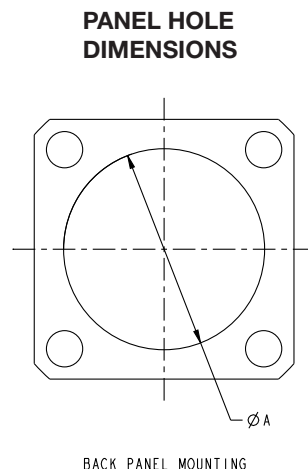
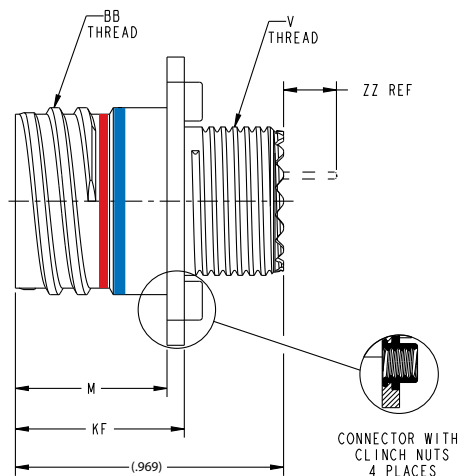
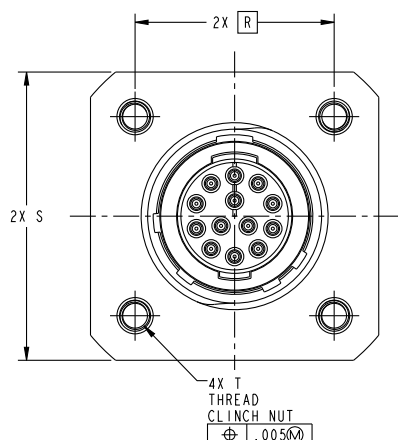

Shell Size	BB Thread	V Thread*	(ØA)	M ±.0030	R	S ±.012	T Thread	KF ±.003	(ZZ)**
8	.5600 - .1P - .2L - DS	.4375 - 28 - UNEF	.606	.5475	.594	.919	.112-40UNC-3B	.613	.250
10	.6800 - .1P - .2L - DS	.5625 - 24 - UNEF	.726	.5475	.719	1.044	.112-40UNC-3B	.613	.250
12	.8000 - .1P - .2L - DS	.6875 - 24 - UNEF	.846	.5475	.812	1.137	.112-40UNC-3B	.613	.250
14	.9200 - .1P - .2L - DS	.8125 - 20 - UNEF	.966	.5475	.906	1.231	.112-40UNC-3B	.613	.250
16	1.1875 - .1P - .2L - DS	.9375 - 20 - UNEF	1.230	.5475	.969	1.294	.112-40UNC-3B	.651	.250
18	1.2500 - .1P - .2L - DS	1.0625 - 18 - UNEF	1.290	.5475	1.062	1.387	.112-40UNC-3B	.651	.250
20	1.3750 - .1P - .2L - DS	1.1875 - 18 - UNEF	1.420	.5475	1.156	1.481	.112-40UNC-3B	.651	.250
22	1.5000 - .1P - .2L - DS	1.3125 - 18 - UNEF	1.540	.5475	1.250	1.667	.138-32UNC-3B	.651	.250
24	1.6250 - .1P - .2L - DS	1.4375 - 18 - UNEF	1.660	.5475	1.375	1.792	.138-32UNC-3B	.651	.250

*Compatible with all D38999 Series II Accessories

**PCB Mod Codes Only



SERIES FIVE WALL MOUNTING DOUBLE FLANGE

S540

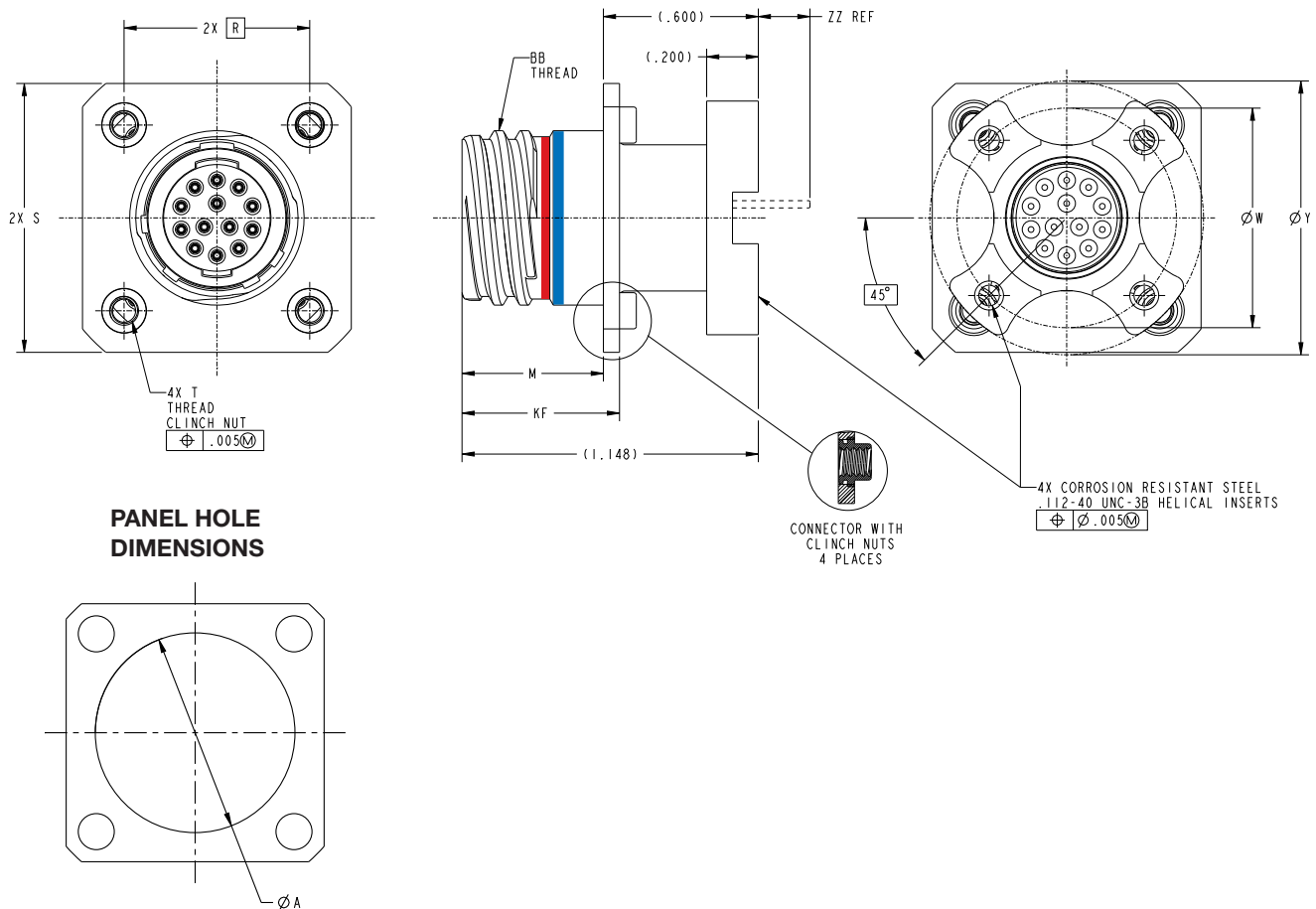

Shell Size	BB Thread	(ØA)	M ±.0030	R	S ±.012	T Thread	ØW	ØY ±.004	KF ±.003	(ZZ)**
8	.5600 - .1P - .2L - DS	.606	.5475	.594	.919	.112-40UNC-3B	.753	1.013	.613	.250
10	.6800 - .1P - .2L - DS	.726	.5475	.719	1.044	.112-40UNC-3B	.850	1.063	.613	.250
12	.8000 - .1P - .2L - DS	.846	.5475	.812	1.137	.112-40UNC-3B	.994	1.251	.613	.250
14	.9200 - .1P - .2L - DS	.966	.5475	.906	1.231	.112-40UNC-3B	1.119	1.376	.613	.250
16	1.1875 - .1P - .2L - DS	1.230	.5475	.969	1.294	.112-40UNC-3B	1.237	1.501	.651	.250
18	1.2500 - .1P - .2L - DS	1.290	.5475	1.062	1.387	.112-40UNC-3B	1.379	1.626	.651	.250
20	1.3750 - .1P - .2L - DS	1.420	.5475	1.156	1.481	.112-40UNC-3B	1.489	1.751	.651	.250
22	1.5000 - .1P - .2L - DS	1.540	.5475	1.250	1.667	.138-32UNC-3B	1.644	1.876	.651	.250
24	1.6250 - .1P - .2L - DS	1.660	.5475	1.375	1.792	.138-32UNC-3B	1.744	2.001	.651	.250

*Compatible with all D38999 Series II Accessories

**PCB Mod Codes Only

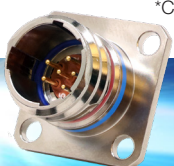

SERIES FIVE JAM NUT RECEPTACLE ACCESSORY THREAD PLUS HEX NUT (729) S507

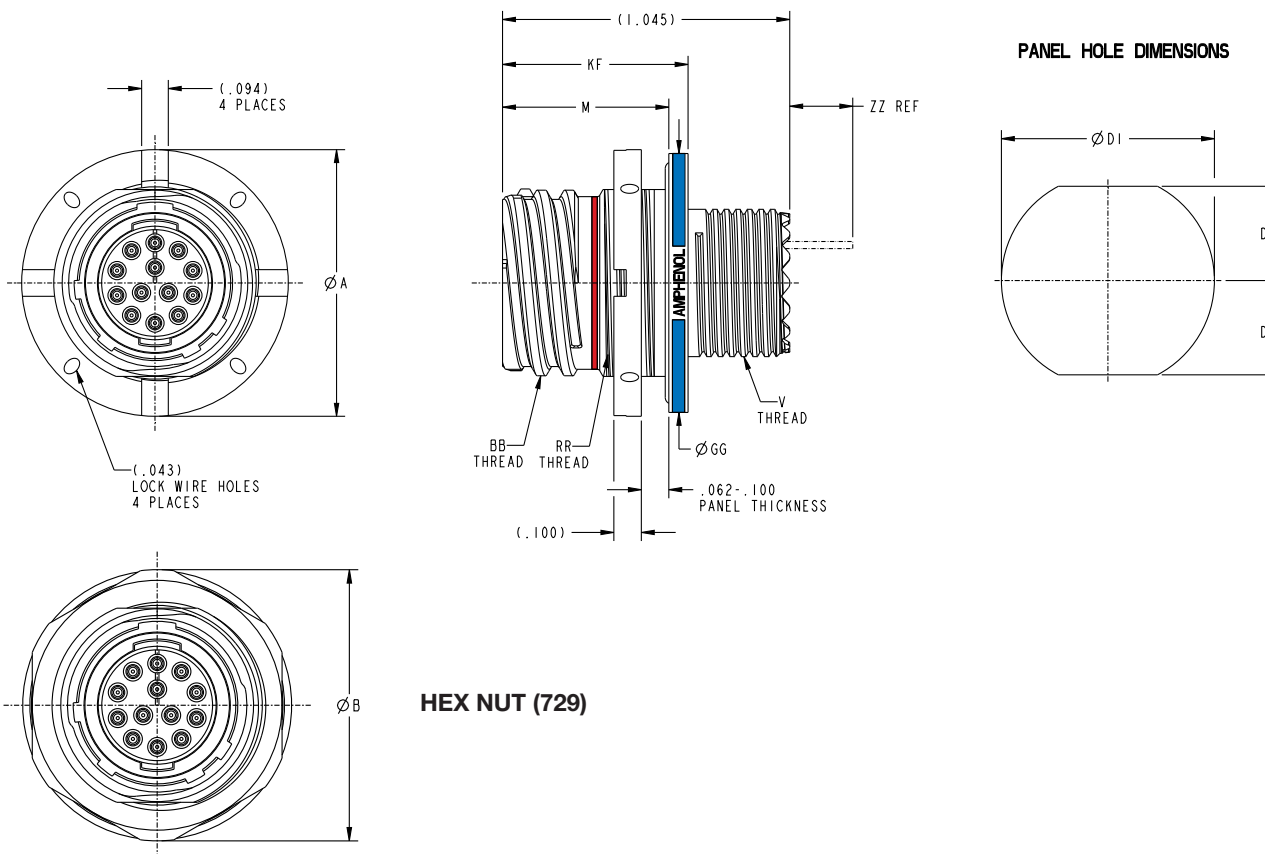

Shell Size	BB Thread	V Thread*	ØA ±.002	ØB ±.005	(ØD1)	(D2)	M ±.003	ØGG ±.002	KF ±.003	RR Threads	(ZZ)
8	.5600 - .1P - .2L - DS	.4375 - 28 - UNEF	.823	.825	.670	.300	.605	.820	.678	.6250 - 24 - UNEF - 2A	.250
10	.6800 - .1P - .2L - DS	.5625 - 24 - UNEF	.973	.953	.800	.360	.605	.945	.678	.7500 - 20 - UNEF - 2A	.250
12	.8000 - .1P - .2L - DS	.6875 - 24 - UNEF	1.094	1.078	.920	.420	.605	1.070	.678	.8750 - 20 - UNEF - 2A	.250
14	.9200 - .1P - .2L - DS	.8125 - 20 - UNEF	1.273	1.203	1.090	.480	.605	1.250	.678	1.0000 - 20 - UNEF - 2A	.250
16	1.1875 - .1P - .2L - DS	.9375 - 20 - UNEF	1.597	1.493	1.300	.600	.605	1.646	.698	1.2500 - 18 - UNEF - 2A	.250
18	1.2500 - .1P - .2L - DS	1.0625 - 18 - UNEF	1.722	1.628	1.420	.640	.605	1.755	.698	1.3750 - 18 - UNEF - 2A	.250
20	1.3750 - .1P - .2L - DS	1.1875 - 18 - UNEF	1.847	1.753	1.550	.700	.605	1.908	.698	1.5000 - 18 - UNEF - 2A	.250
22	1.5000 - .1P - .2L - DS	1.3125 - 18 - UNEF	1.972	1.878	1.670	.760	.605	2.033	.698	1.6250 - 18 - UNS - 2A	.250
24	1.6250 - .1P - .2L - DS	1.4375 - 18 - UNEF	2.112	2.003	1.800	.820	.605	2.158	.698	1.7500 - 18 - UNS - 2A	.250

*Compatible with all D38999 Series II Accessories



SERIES FIVE JAM NUT INTEGRAL BANDING PLATFORM

S587

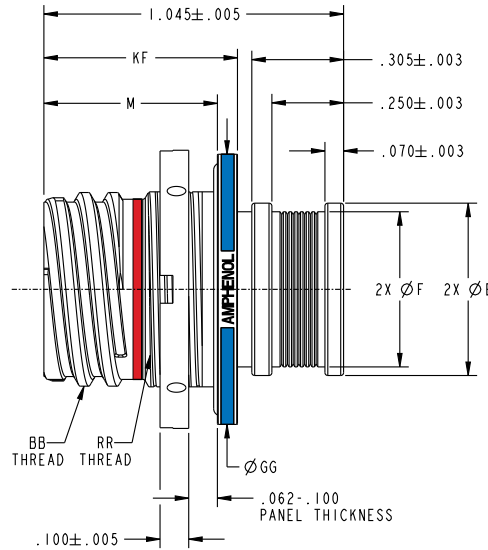
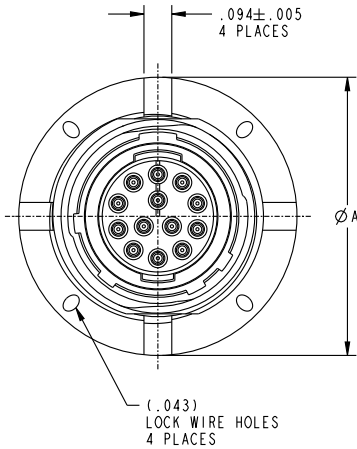

PANEL HOLE DIMENSIONS

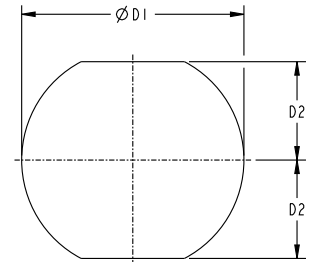

Shell Size	$\varnothing A$ $\pm .002$	$(\varnothing D1)$	$(D2)$	$\varnothing E$ $\pm .002$	$\varnothing F$ $\pm .002$	M $\pm .003$	BB Thread	$\varnothing GG$ $\pm .002$	KF $\pm .003$	RR Thread
8	.823	.670	.300	.483	.423	.605	.5600 - .1P - .2L - DS	.820	.678	.6250 - 24 - UNEF - 2A
10	.973	.800	.360	.604	.544	.605	.6800 - .1P - .2L - DS	.945	.678	.7500 - 20 - UNEF - 2A
12	1.094	.920	.420	.729	.669	.605	.8000 - .1P - .2L - DS	1.070	.678	.8750 - 20 - UNEF - 2A
14	1.273	1.090	.480	.863	.803	.605	.9200 - .1P - .2L - DS	1.250	.678	1.0000 - 20 - UNEF - 2A
16	1.597	1.300	.600	.978	.918	.605	1.1875 - .1P - .2L - DS	1.646	.698	1.2500 - 18 - UNEF - 2A
18	1.722	1.420	.640	1.096	1.036	.605	1.2500 - .1P - .2L - DS	1.755	.698	1.3750 - 18 - UNEF - 2A
20	1.847	1.550	.700	1.220	1.160	.605	1.3750 - .1P - .2L - DS	1.908	.698	1.5000 - 18 - UNEF - 2A
22	1.972	1.670	.760	1.345	1.285	.605	1.5000 - .1P - .2L - DS	2.033	.698	1.6250 - 18 - UNS - 2A
24	2.112	1.800	.820	1.470	1.410	.605	1.6250 - .1P - .2L - DS	2.158	.698	1.7500 - 18 - UNS - 2A

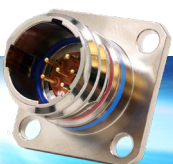

SERIES FIVE JAM NUT RECEPTACLE WITH WASHOUT STANDOFF

S517

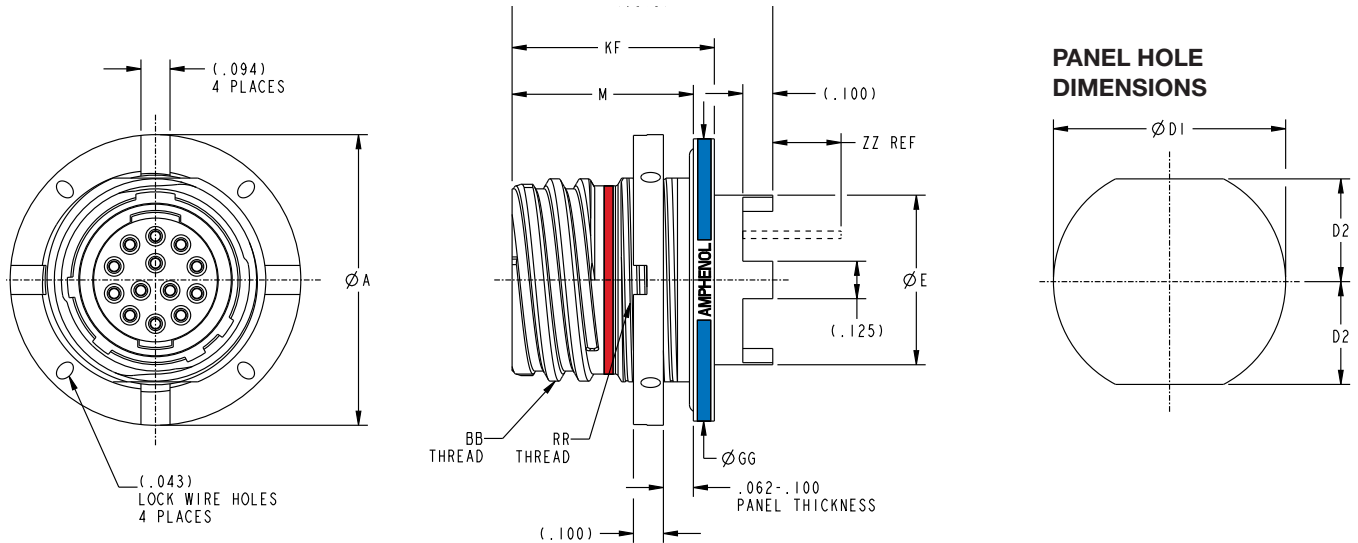

Shell Size	ØA ±.002	(ØD1)	(D2)	ØE ±.005	M ±.003	BB Thread	ØGG ±.002	KF ±.002	RR Thread	(ZZ)**
8	.823	.670	.300	.448	.605	.5600 - .1P - .2L - DS	.820	.678	.6250 - 24 - UNEF - 2A	.250
10	.973	.800	.360	.569	.605	.6800 - .1P - .2L - DS	.945	.678	.7500 - 20 - UNEF - 2A	.250
12	1.094	.920	.420	.694	.605	.8000 - .1P - .2L - DS	1.070	.678	.8750 - 20 - UNEF - 2A	.250
14	1.273	1.090	.480	.818	.605	.9200 - .1P - .2L - DS	1.250	.678	1.0000 - 20 - UNEF - 2A	.250
16	1.597	1.300	.600	.943	.605	1.1875 - .1P - .2L - DS	1.646	.698	1.2500 - 18 - UNEF - 2A	.250
18	1.722	1.420	.640	1.061	.605	1.2500 - .1P - .2L - DS	1.755	.698	1.3750 - 18 - UNEF - 2A	.250
20	1.847	1.550	.700	1.185	.605	1.3750 - .1P - .2L - DS	1.908	.698	1.5000 - 18 - UNEF - 2A	.250
22	1.972	1.670	.760	1.310	.605	1.5000 - .1P - .2L - DS	2.033	.698	1.6250 - 18 - UNS - 2A	.250
24	2.112	1.800	.820	1.435	.605	1.6250 - .1P - .2L - DS	2.158	.698	1.7500 - 18 - UNS - 2A	.250

**PCB Mod Codes Only



SERIES FIVE JAM NUT RECEPTACLE WITH STANDOFFS

S598

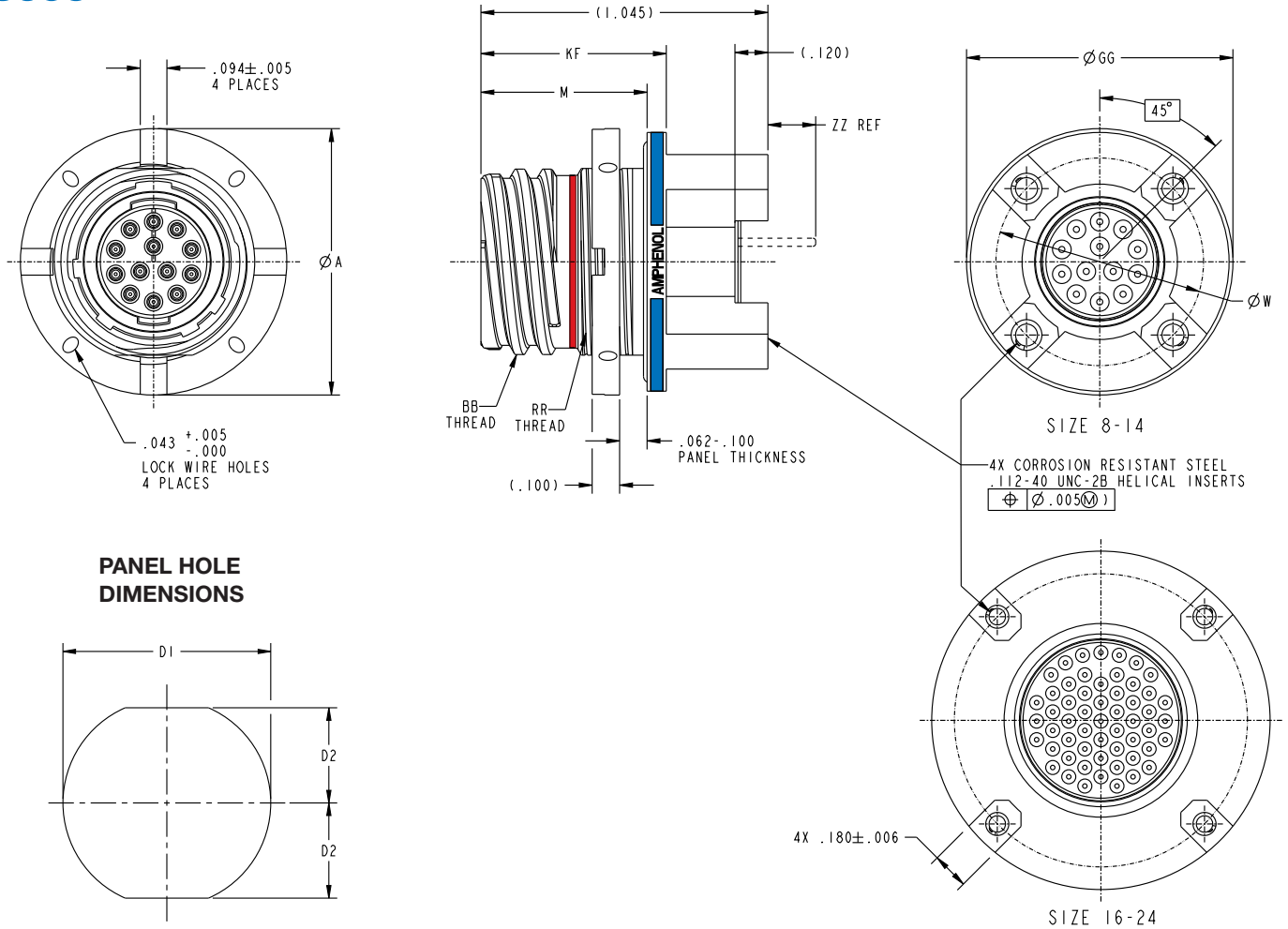

PANEL HOLE DIMENSIONS

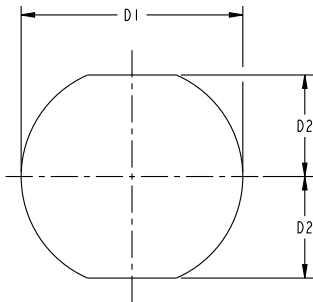

Shell Size	ØA ±.002	(ØD1)	(D2)	M ±.003	BB Thread	ØGG ±.002	KF ±.003	RR Thread	ØW	(ZZ)**
8	.823	.670	.300	.605	.5600 - .1P - .2L - DS	.820	.678	.6250 - 24 - UNEF - 2A	.631	.250
10	.973	.800	.360	.605	.6800 - .1P - .2L - DS	.945	.678	.7500 - 20 - UNEF - 2A	.754	.250
12	1.094	.920	.420	.605	.8000 - .1P - .2L - DS	1.070	.678	.8750 - 20 - UNEF - 2A	.879	.250
14	1.273	1.090	.480	.605	.9200 - .1P - .2L - DS	1.250	.678	1.000 - 20 - UNEF - 2A	1.031	.250
16	1.597	1.300	.600	.605	1.1875 - .1P - .2L - DS	1.646	.698	1.2500 - 18 - UNEF - 2A	1.423	.250
18	1.722	1.420	.640	.605	1.2500 - .1P - .2L - DS	1.755	.698	1.3750 - 18 - UNEF - 2A	1.532	.250
20	1.847	1.550	.700	.605	1.3750 - .1P - .2L - DS	1.908	.698	1.5000 - 18 - UNEF - 2A	1.685	.250
22	1.972	1.670	.760	.605	1.5000 - .1P - .2L - DS	2.033	.698	1.6250 - 18 - UNS - 2A	1.810	.250
24	2.112	1.800	.820	.605	1.6250 - .1P - .2L - DS	2.158	.698	1.7500 - 18 - UNS - 2A	1.935	.250

**PCB Mod Codes Only

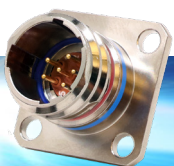

SERIES FIVE BOX MOUNT RECEPTACLE

S502



PANEL HOLE DIMENSIONS

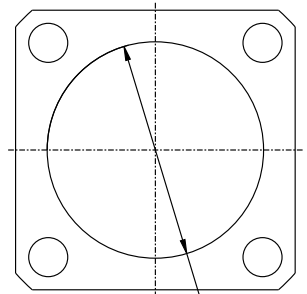

BACK PANEL MOUNTING

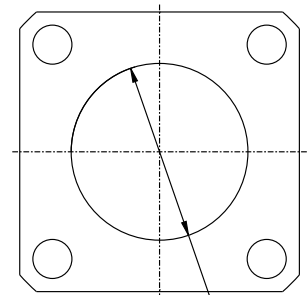

FRONT PANEL MOUNTING

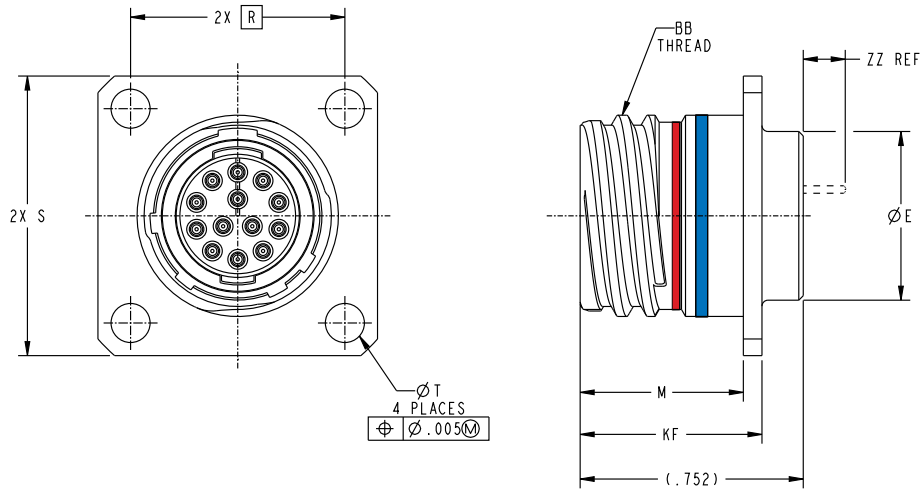

Shell Size	BB Thread	(ØA1)	(ØA2)	ØE ±.005	M ±.0030	R	S ±.012	ØT ±.008	KF ±.003	(ZZ)**
8	.5600 - .1P - .2L - DS	.606	.468	.448	.5475	.594	.815	.128	.613	.250
10	.6800 - .1P - .2L - DS	.726	.593	.569	.5475	.719	.941	.128	.613	.250
12	.8000 - .1P - .2L - DS	.846	.718	.694	.5475	.812	1.034	.128	.613	.250
14	.9200 - .1P - .2L - DS	.966	.843	.818	.5475	.906	1.128	.128	.613	.250
16	1.1875 - .1P - .2L - DS	1.230	.967	.943	.5475	.969	1.222	.128	.651	.250
18	1.2500 - .1P - .2L - DS	1.290	1.085	1.061	.5475	1.062	1.315	.128	.651	.250
20	1.3750 - .1P - .2L - DS	1.420	1.209	1.185	.5475	1.156	1.441	.128	.651	.250
22	1.5000 - .1P - .2L - DS	1.540	1.334	1.310	.5475	1.250	1.565	.154	.651	.250
24	1.6250 - .1P - .2L - DS	1.660	1.459	1.435	.5475	1.375	1.671	.154	.651	.250

**PCB Mod Codes Only



SERIES FIVE BOX MOUNTING RECEPTACLE - CLINCH NUTS

S512

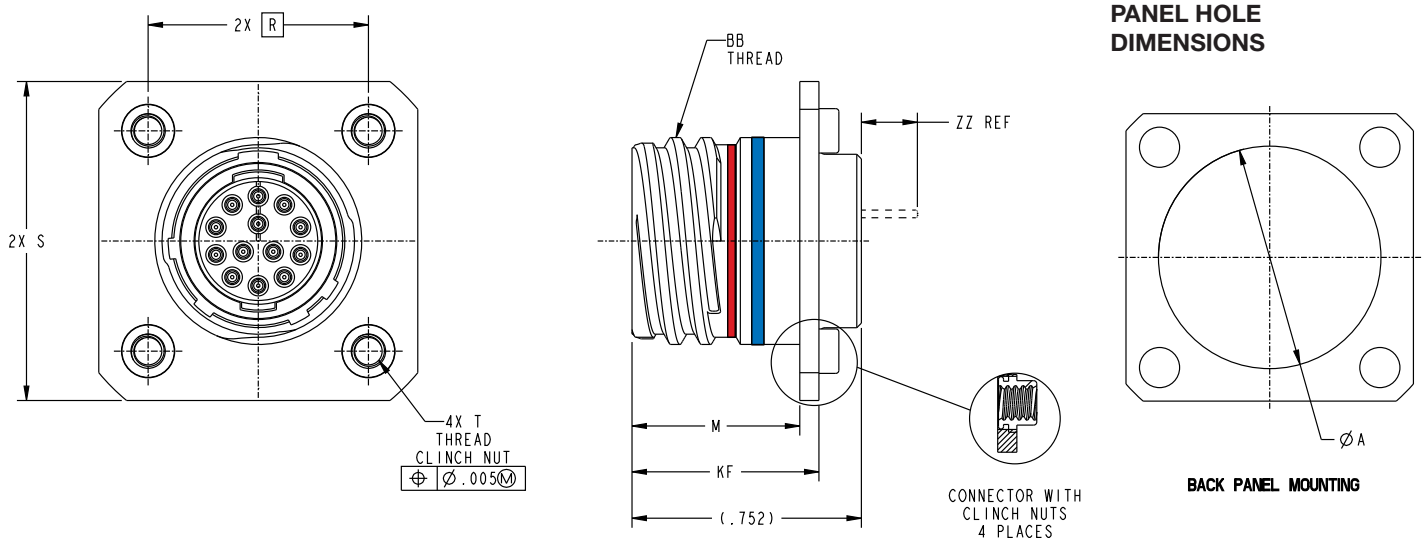

Shell Size	BB Thread	($\varnothing A$)	M $\pm .0030$	R	S $\pm .012$	T Thread	KF $\pm .003$	(ZZ)**
8	.5600 - .1P - .2L - DS	.606	.5475	.594	.919	.112-40UNC-38	.613	.250
10	.6800 - .1P - .2L - DS	.726	.5475	.719	1.044	.112-40UNC-38	.613	.250
12	.8000 - .1P - .2L - DS	.846	.5475	.812	1.137	.112-40UNC-38	.613	.250
14	.9200 - .1P - .2L - DS	.966	.5475	.906	1.231	.112-40UNC-38	.613	.250
16	1.1875 - .1P - .2L - DS	1.230	.5475	.969	1.294	.112-40UNC-38	.651	.250
18	1.2500 - .1P - .2L - DS	1.290	.5475	1.062	1.387	.112-40UNC-38	.651	.250
20	1.3750 - .1P - .2L - DS	1.420	.5475	1.156	1.481	.112-40UNC-38	.651	.250
22	1.5000 - .1P - .2L - DS	1.540	.5475	1.250	1.667	.138-32UNC-38	.651	.250
24	1.6250 - .1P - .2L - DS	1.660	.5475	1.375	1.792	.138-32UNC-38	.651	.250

**PCB Mod Codes Only

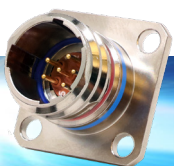

SERIES FIVE LINE MOUNTING RECEPTACLE S501

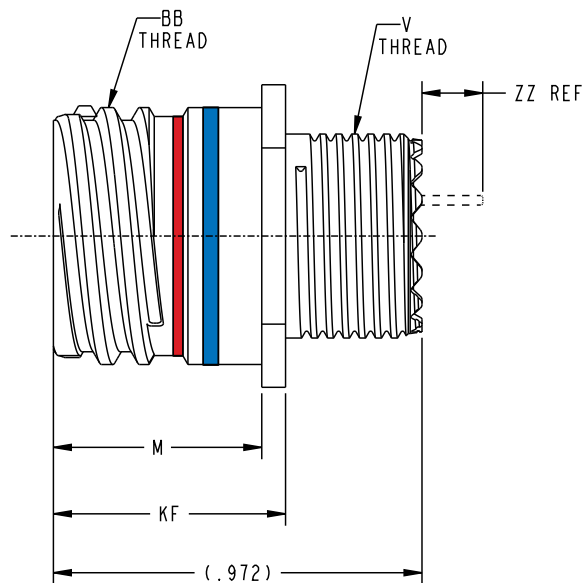
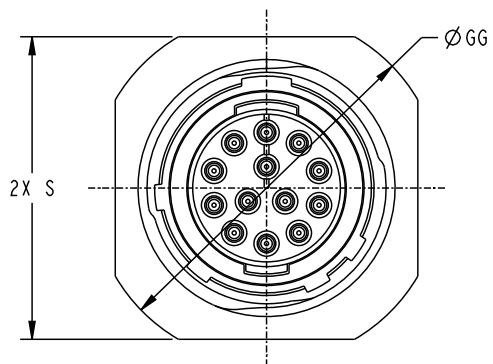

Shell Size	BB Thread	V Thread*	M ±.003	S ±.012	ØGG ±.010	KF ±.003	(ZZ)**
8	.5600 - .1P - .2L - DS	.4375 - 28 - UNEF	.5475	.678	.803	.613	.250
10	.6800 - .1P - .2L - DS	.5625 - 24 - UNEF	.5475	.798	.923	.613	.250
12	.8000 - .1P - .2L - DS	.6875 - 24 - UNEF	.5475	.918	1.043	.613	.250
14	.9200 - .1P - .2L - DS	.8125 - 20 - UNEF	.5475	1.038	1.163	.613	.250
16	1.1875 - .1P - .2L - DS	.9375 - 20 - UNEF	.5475	1.305	1.503	.613	.250
18	1.2500 - .1P - .2L - DS	1.0625 - 18 - UNEF	.5475	1.367	1.628	.613	.250
20	1.3750 - .1P - .2L - DS	1.1875 - 18 - UNEF	.5475	1.503	1.758	.613	.250
22	1.5000 - .1P - .2L - DS	1.3125 - 18 - UNEF	.5475	1.629	1.878	.613	.250
24	1.6250 - .1P - .2L - DS	1.4375 - 18 - UNEF	.5475	1.753	2.003	.613	.250

*Compatible with all D38999 Series II Accessories

**PCB Mod Codes Only



SERIES FIVE JAM NUT WITH DOUBLE FLANGE RECEPTACLES

S547

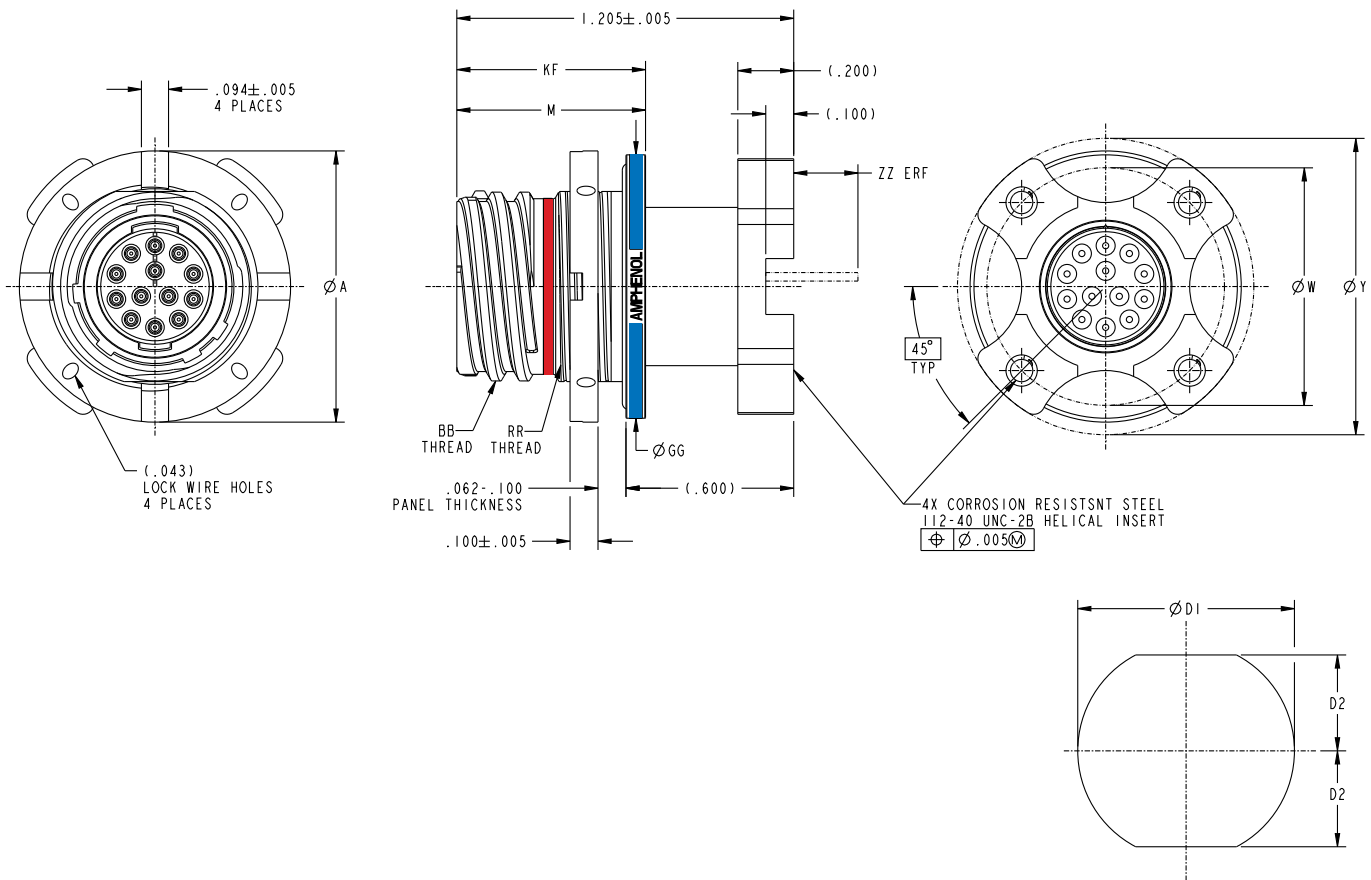

Shell Size	BB Thread	ØA ±.002	(ØD1)	(D2)	M ±.003	ØGG ±.002	ØW	(ØY)	KF ±.003	RR Thread	(ZZ)
8	.5600 - .1P - .2L - DS	.823	.670	.300	.605	.820	.753	1.013	.678	.6250 - 24 - UNEF - 2A	.250
10	.6800 - .1P - .2L - DS	.973	.800	.360	.605	.945	.850	1.063	.678	.7500 - 20 - UNEF - 2A	.250
12	.8000 - .1P - .2L - DS	1.094	.920	.420	.605	1.070	.994	1.251	.678	.8750 - 20 - UNEF - 2A	.250
14	.9200 - .1P - .2L - DS	1.273	1.090	.480	.605	1.250	1.119	1.376	.678	1.0000 - 20 - UNEF - 2A	.250
16	1.1875 - .1P - .2L - DS	1.597	1.300	.600	.605	1.646	1.237	1.501	.698	1.2500 - 18 - UNEF - 2A	.250
18	1.2500 - .1P - .2L - DS	1.722	1.420	.640	.605	1.755	1.379	1.626	.698	1.3750 - 18 - UNEF - 2A	.250
20	1.3750 - .1P - .2L - DS	1.847	1.550	.700	.605	1.908	1.489	1.751	.698	1.5000 - 18 - UNEF - 2A	.250
22	1.5000 - .1P - .2L - DS	1.972	1.670	.760	.605	2.033	1.644	1.876	.698	1.6250 - 18 - UNEF - 2A	.250
24	1.6250 - .1P - .2L - DS	2.112	1.800	.820	.605	2.158	1.744	2.001	.698	1.7500 - 18 - UNEF - 2A	.250

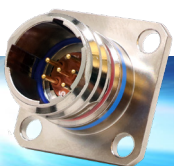

SERIES FIVE SQUARE FLANGE RECEPTACLE WITH SHORT STANDOFFS AND CLINCH NUTS



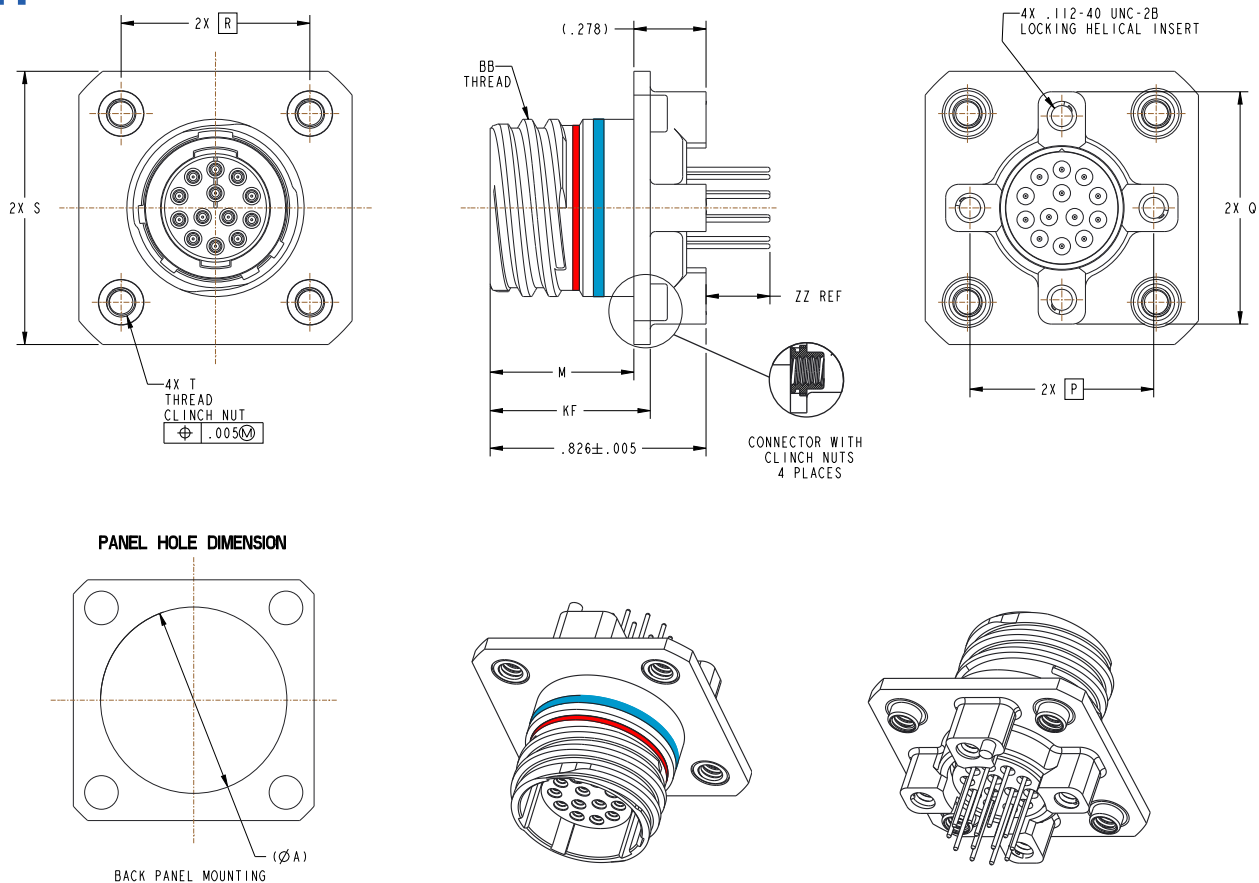











S541



Shell Size	BB Thread, Blunt Ends (Both Start & Stop) Per 9-10046-4 or 9-3200	(ØA)	M ±.0025	P	Q ±.012	R	S ±.012	(ØT) Thread	KF ±.003	(ZZ)
8	.5600 - .1P - .2L - DS	.606	.5475	.600	.788	.594	.919	.112-40UNC-3B	.613	.250
10	.6800 - .1P - .2L - DS	.726	.5475	.700	.888	.719	1.044	.112-40UNC-3B	.613	.250
12	.8000 - .1P - .2L - DS	.846	.5475	.850	1.038	.812	1.137	.112-40UNC-3B	.613	.250
14	.9200 - .1P - .2L - DS	.966	.5475	1.000	1.188	.906	1.231	.112-40UNC-3B	.613	.250
16	1.1875 - .1P - .2L - DS	1.230	.5475	1.100	1.294	.969	1.294	.112-40UNC-3B	.651	.250
18	1.2500 - .1P - .2L - DS	1.290	.5475	1.200	1.387	1.062	1.387	.112-40UNC-3B	.651	.250
20	1.3750 - .1P - .2L - DS	1.420	.5475	1.290	1.481	1.156	1.481	.112-40UNC-3B	.651	.250
22	1.5000 - .1P - .2L - DS	1.540	.5475	1.475	1.667	1.230	1.667	.138-32UNC-3B	.651	.250
24	1.6250 - .1P - .2L - DS	1.660	.5475	1.600	1.792	1.375	1.792	.138-32UNC-3B	.651	.250



HOW TO ORDER: BULKHEAD FEED-THROUGH BS500DS-10-35PSN

1. Connector Type	2. Shell Style	3. Service Class	4. Shell Size - Insert Arrg.	5. Contact Type	6. Alternate Positions	7. Mod (Optional)																																								
S5	00	DS-	14-35	PS	N	(453) Space Grade																																								
<p>1. Connector Type BS5 Series Five Bulkhead Feed-Through</p> <p>2. Shell Style*</p> <table border="1"> <tr> <td>00</td> <td>Wall Mount Receptacle pg 30</td> </tr> <tr> <td>07</td> <td>Jam Nut with Accessory Thread pg 31</td> </tr> </table> <p>*Other shell styles available consult Amphenol for more information</p> <p>3. 175°C Service Class</p> <table border="1"> <tr> <td>DT-</td> <td>Durmalon </td> </tr> <tr> <td>DZ-</td> <td>Black Zinc-Nickel </td> </tr> <tr> <td>DW-</td> <td>Olive Drab Cadmium</td> </tr> </table> <p>3. 200°C Service Class</p> <table border="1"> <tr> <td>DR-</td> <td>Electroless Nickel </td> </tr> <tr> <td>DS*-</td> <td>AP-93 </td> </tr> <tr> <td>RK-</td> <td>Passivated Stainless Steel </td> </tr> <tr> <td>RS-</td> <td>Nickel plated, Stainless Steel </td> </tr> </table> <p>See page 12-13 for plating options</p> <p>6. Alternate Positions</p> <table border="1"> <tr> <td>N</td> <td>Normal Rotation</td> </tr> <tr> <td>A</td> <td>A Rotation</td> </tr> <tr> <td>B</td> <td>B Rotation</td> </tr> <tr> <td>C</td> <td>C Rotation</td> </tr> <tr> <td>D</td> <td>D Rotation</td> </tr> <tr> <td>E</td> <td>E Rotation</td> </tr> <tr> <td>U</td> <td>Universal Keying</td> </tr> </table> <p>See pages 15 for more information</p> <p>5. Contact Type*</p> <table border="1"> <tr> <td>PS</td> <td>Pin-Socket</td> </tr> <tr> <td>SP</td> <td>Socket-Pin</td> </tr> <tr> <td>PP</td> <td>Pin-Pin</td> </tr> <tr> <td>SS</td> <td>Socket-Socket</td> </tr> </table> <p>*Note: First letter designates the panel side of the connector (see drawings) while the second letter in the sequence designates the opposite side. Same gender configurations only available with symmetrical insert arrangements. The PP and SS configurations are only available on symmetrical insert arrangements</p> <p>4. Shell Size/ Insert Arrangement See pages 10-11. Voltage ratings per MIL DTL-38999 service ratings for bulkhead feedthroughs and not Series Five service ratings</p>							00	Wall Mount Receptacle pg 30	07	Jam Nut with Accessory Thread pg 31	DT-	Durmalon 	DZ-	Black Zinc-Nickel 	DW-	Olive Drab Cadmium	DR-	Electroless Nickel 	DS*-	AP-93 	RK-	Passivated Stainless Steel 	RS-	Nickel plated, Stainless Steel 	N	Normal Rotation	A	A Rotation	B	B Rotation	C	C Rotation	D	D Rotation	E	E Rotation	U	Universal Keying	PS	Pin-Socket	SP	Socket-Pin	PP	Pin-Pin	SS	Socket-Socket
00	Wall Mount Receptacle pg 30																																													
07	Jam Nut with Accessory Thread pg 31																																													
DT-	Durmalon 																																													
DZ-	Black Zinc-Nickel 																																													
DW-	Olive Drab Cadmium																																													
DR-	Electroless Nickel 																																													
DS*-	AP-93 																																													
RK-	Passivated Stainless Steel 																																													
RS-	Nickel plated, Stainless Steel 																																													
N	Normal Rotation																																													
A	A Rotation																																													
B	B Rotation																																													
C	C Rotation																																													
D	D Rotation																																													
E	E Rotation																																													
U	Universal Keying																																													
PS	Pin-Socket																																													
SP	Socket-Pin																																													
PP	Pin-Pin																																													
SS	Socket-Socket																																													

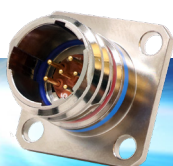

SERIES FIVE BULKHEAD FEED-THROUGH WALL MOUNTING

BS500

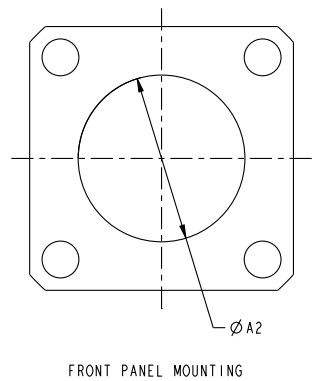
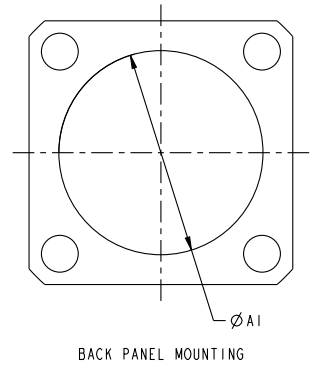
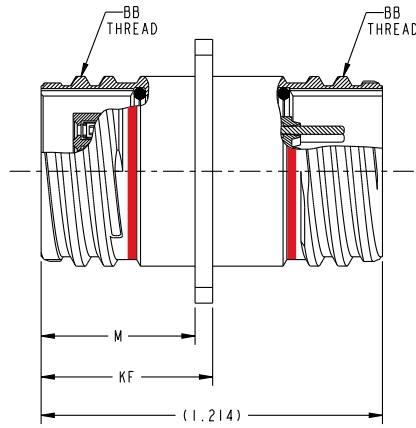
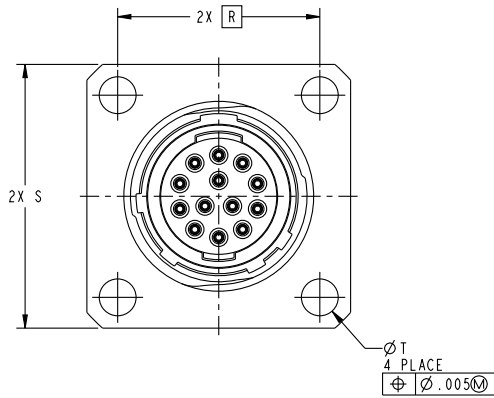

Shell Size	BB Thread	(ØA1)	(ØA2)	M ±.0030	R	S ±.012	(ØT)	KF ±.003
8	.5600 - .1P - .2L - DS	.606	.606	.5475	.594	.812	.128	.613
10	.6800 - .1P - .2L - DS	.726	.726	.5475	.719	.941	.128	.613
12	.8000 - .1P - .2L - DS	.846	.846	.5475	.812	1.034	.128	.613
14	.9200 - .1P - .2L - DS	.966	.966	.5475	.906	1.128	.128	.613
16	1.1875 - .1P - .2L - DS	1.230	1.230	.5475	.969	1.222	.128	.651
18	1.2500 - .1P - .2L - DS	1.290	1.290	.5475	1.062	1.315	.128	.651
20	1.3750 - .1P - .2L - DS	1.420	1.420	.5475	1.156	1.441	.128	.651
22	1.5000 - .1P - .2L - DS	1.540	1.540	.5475	1.250	1.565	.154	.651
24	1.6250 - .1P - .2L - DS	1.660	1.660	.5475	1.375	1.691	.154	.651

*Compatible with all D38999 Series II Accessories



SERIES FIVE BULKHEAD FEED-THROUGH JAM NUT BS507

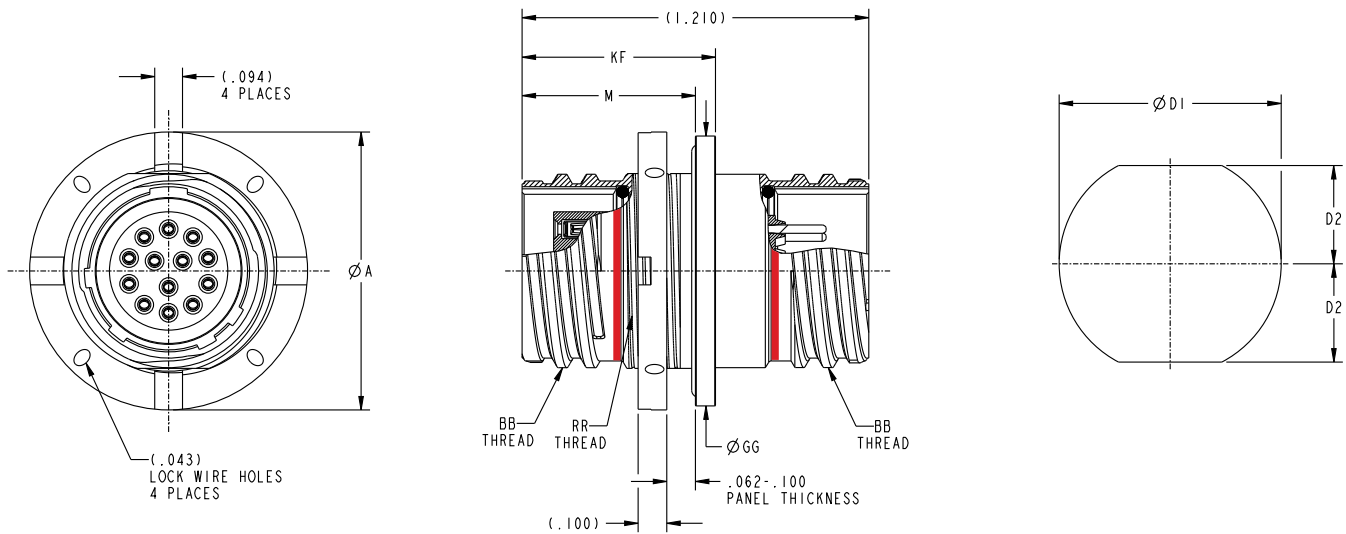

Shell Size	ØA ±.002	BB Thread	(D1)	(D2)	M ±.003	ØGG ±.002	KF ±.002	RR Threads
8	.823	.5600 - .1P - .2L - DS	.670	.300	.605	.820	.678	.6250 - 24 - UNEF - 2A
10	.973	.6800 - .1P - .2L - DS	.800	.360	.605	.945	.678	.7500 - 20 - UNEF - 2A
12	1.094	.8000 - .1P - .2L - DS	.920	.420	.605	1.070	.678	.8750 - 20 - UNEF - 2A
14	1.273	.9200 - .1P - .2L - DS	1.090	.480	.605	1.250	.678	1.0000 - 20 - UNEF - 2A
16	1.597	1.1875 - .1P - .2L - DS	1.300	.600	.605	1.646	.698	1.2500 - 18 - UNEF - 2A
18	1.722	1.2500 - .1P - .2L - DS	1.420	.640	.605	1.755	.698	1.3750 - 18 - UNEF - 2A
20	1.847	1.3750 - .1P - .2L - DS	1.550	.700	.605	1.908	.698	1.5000 - 18 - UNEF - 2A
22	1.972	1.5000 - .1P - .2L - DS	1.670	.760	.605	2.033	.698	1.6250 - 18 - UNS - 2A
24	2.112	1.6250 - .1P - .2L - DS	1.800	.820	.605	2.158	.698	1.7500 - 18 - UNS - 2A

*Compatible with all D38999 Series II Accessories

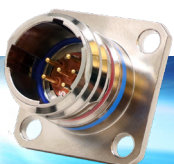

HOW TO ORDER: SERIES FIVE PROTECTION CAPS

EX: S5PPC-T10-N5

1. Cap Type		2. Service Class	3. Shell Size	4. Attachment Type		5. Lanyard Length	
S5PPC-		T	10-	N		5	
1. Cap Type S5PPC- Plug Protection Cap S5RPC- Receptacle Protection Cap		2. 175°C Service Class T Durmalon Z Black Zinc Nickel W Olive Drab Cadmium	3. Shell Size 8- 10- 12- 14- 16- 18- 20- 22- 24-	4. Attachment Type N Washer R Eyelet X No Attachment		5. Lanyard Length 1 Inches 2 Inches 3 Inches 4 inches 5 Inches 6 Inches 7 Inches 8 Inches 9 Inches	
2. 200°C Service Class DS AP-93 *See page 53 for info RB Aluminum Bronze F Electroless nickel G Electroless nickel Space Grade K Passivated Stainless Steel KS Nickel plated Stainless Steel		(MS standard is 5 inches)					

*See page 12 for plating information



SERIES FIVE RECEPTACLE PROTECTION CAP S5RPC

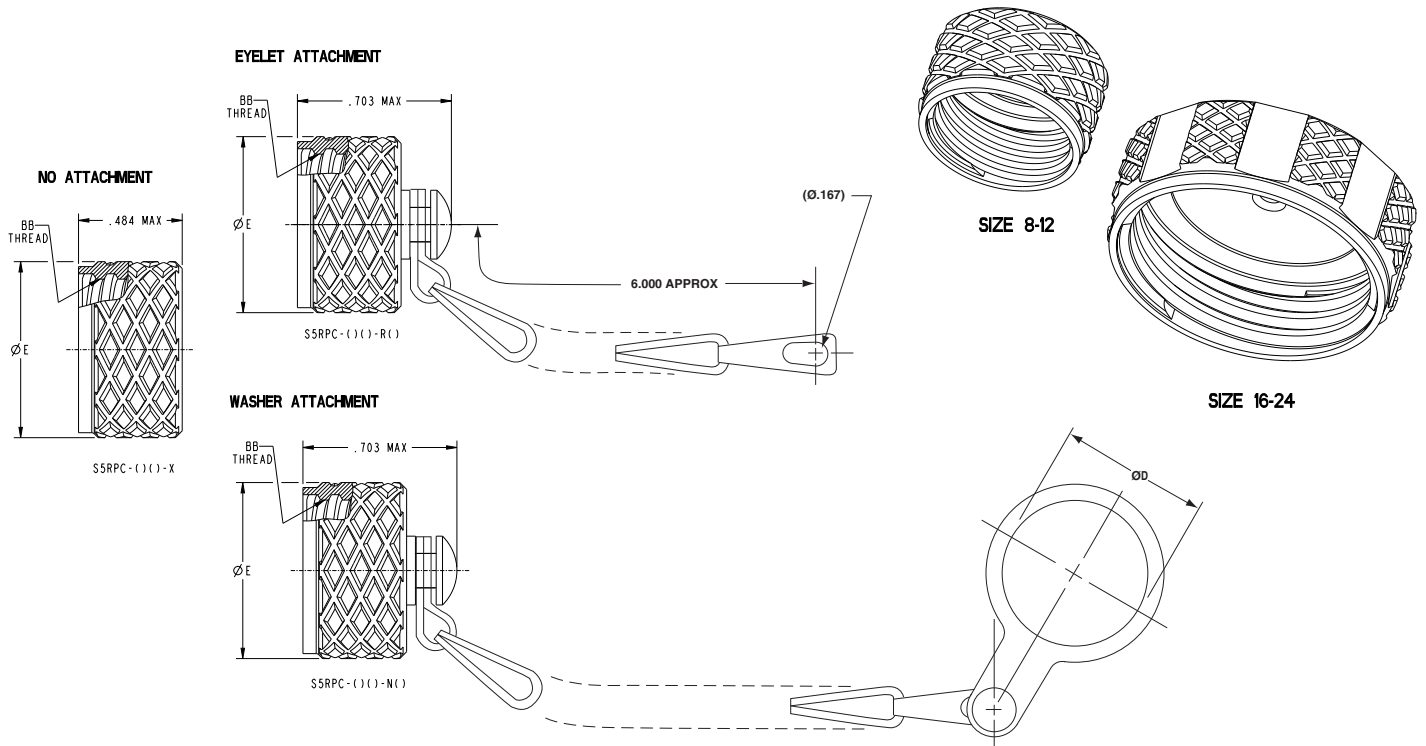

Shell Size	ØE ±.005	ØD +.010 -.000	BB Thread
8	.681	.641	.5600 - .1P - .2L - DS
10	.801	.766	.6800 - .1P - .2L - DS
12	.921	.891	.8000 - .1P - .2L - DS
14	1.041	1.016	.9200 - .1P - .2L - DS
16	1.387	1.266	1.1875 - .1P - .2L - DS
18	1.494	1.391	1.2500 - .1P - .2L - DS
20	1.621	1.516	1.3750 - .1P - .2L - DS
22	1.738	1.641	1.5000 - .1P - .2L - DS
24	1.865	1.766	1.6250 - .1P - .2L - DS

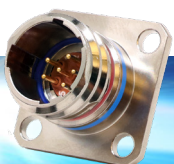

SERIES FIVE PLUG PROTECTION CAP

S5PPC

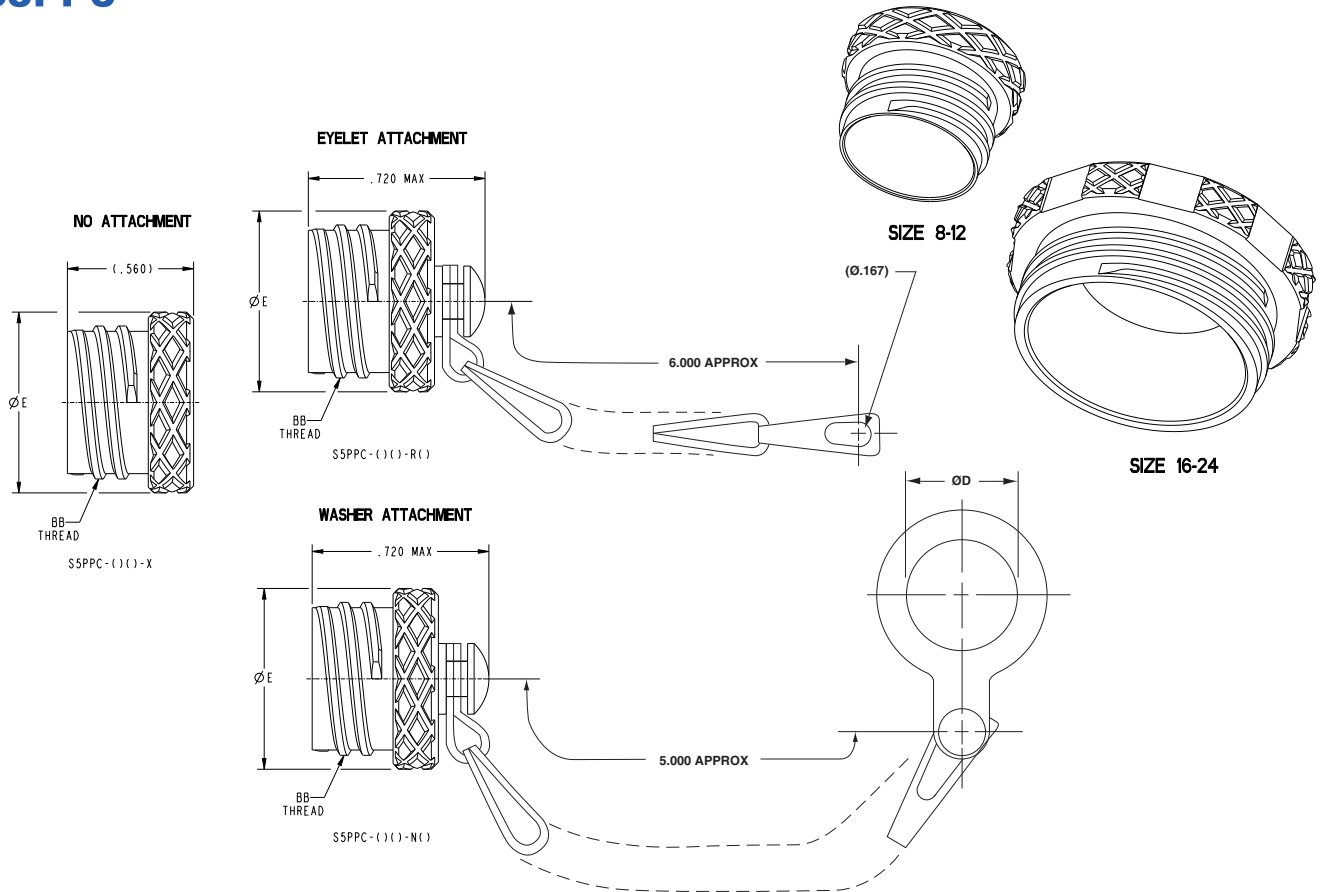

Shell Size	$\text{ØE} \pm .005$	$\text{ØD} \begin{matrix} +.010 \\ -.000 \end{matrix}$	BB Thread
8	.681	.516	.5600 - .1P - .2L - DS
10	.801	.641	.6800 - .1P - .2L - DS
12	.921	.703	.8000 - .1P - .2L - DS
14	1.041	.844	.9200 - .1P - .2L - DS
16	1.387	.969	1.1875 - .1P - .2L - DS
18	1.494	1.094	1.2500 - .1P - .2L - DS
20	1.621	1.141	1.3750 - .1P - .2L - DS
22	1.738	1.343	1.5000 - .1P - .2L - DS
24	1.865	1.453	1.6250 - .1P - .2L - DS



SERIES FIVE JAM NUT SPANNER ENVELOPE

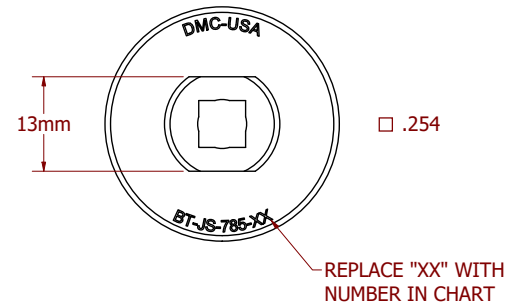
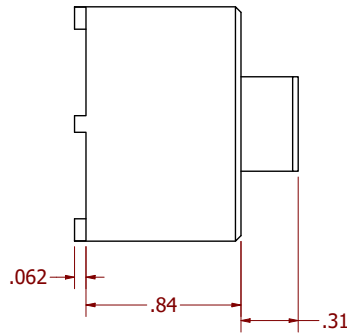
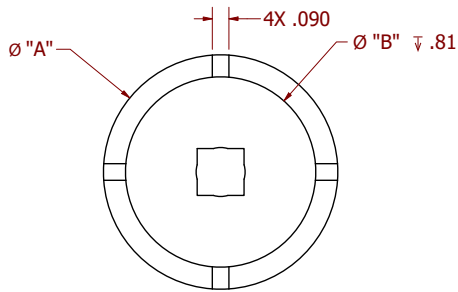
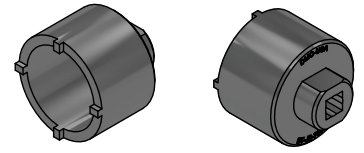

Part Number	Shell Size	A	B
BT-JS-785-08	08	.850	.656
BT-JS-785-10	10	.970	.781
BT-JS-785-12	12	1.091	.906
BT-JS-785-14	14	1.270	1.031
BT-JS-785-16	16		
BT-JS-785-18	18		
BT-JS-785-20	20		
BT-JS-785-22	22		
BT-JS-785-24	24		

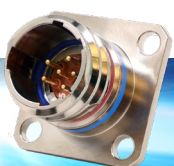

SERIES FIVE HERMETIC WITH GLASS-TO-METAL SEAL

Amphenol offers superior electrical performance plus the rugged design of a glass-sealed connector with superior leak rate performance. Series Five glass-sealed hermetic connectors are available in a wide variety of configurations and shell styles. Utilizing Mil-DTL-38999 qualified glass inserts and contacts, you can reduce the form factor of your design without making compromises on performance.

FEATURES & BENEFITS

- Provide superior sealing of 1×10^{-8} cc/sec helium, 100% tested prior to shipping
- Low profile shells for minimum box protrusion
- Less than half the weight and size of similar MIL-DTL-38999
- “Anti-Decoupling” ratchet mechanism and ground spring for military airframes and avionics boxes. Fast Mating, dual start threads
- Shell standoffs for PC Board washout



WELD MOUNT VERSION SHOWN

Contact Factory for availability



HOW TO ORDER: SERIES FIVE HERMETIC S5IY-14-35PN

1. Connector Type	2. Shell Style	3. Service Class	4. Shell Size - Insert Arrg.	5. Contact Type	6. Alternate Positions	7. Mod (Optional)
S5	I	Y-	14-35	P	N	<p>(729) Hex Nut replacing the spanner nut (Jam Nut only)</p> <p>(453) Space Grade</p> <p>(V25) PCB contacts installed, .250" stickout</p>

1. Connector Type

S5 Series Five

2. Shell Style*

07 Jam Nut Receptacle with Standoff

02 Box Mount Receptacle

*Other shell styles available consult Amphenol for more information

3. 200°C Service Class

Y- Stainless Steel



YN- Nickel Plated Stainless Steel



6. Alternate Positions

N Normal Rotation

A A Rotation

B B Rotation

C C Rotation

D D Rotation

E E Rotation

See pages 15 for more information

5. Contact Type

P Pin (Recommended for receptacles)

X Pin Contacts-Eyelet

C PC Tail

4. Shell Size/ Insert Arrangement

See pages 10-11

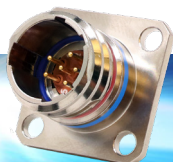

SERIES FIVE HERMETIC JAM NUT WITH STANDOFF

S507Y

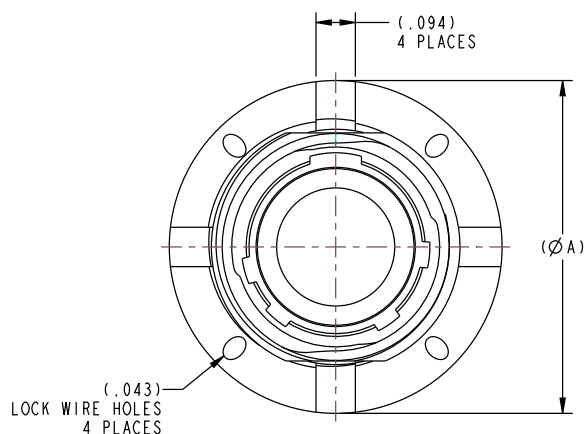

PANEL HOLE DIMENSIONS

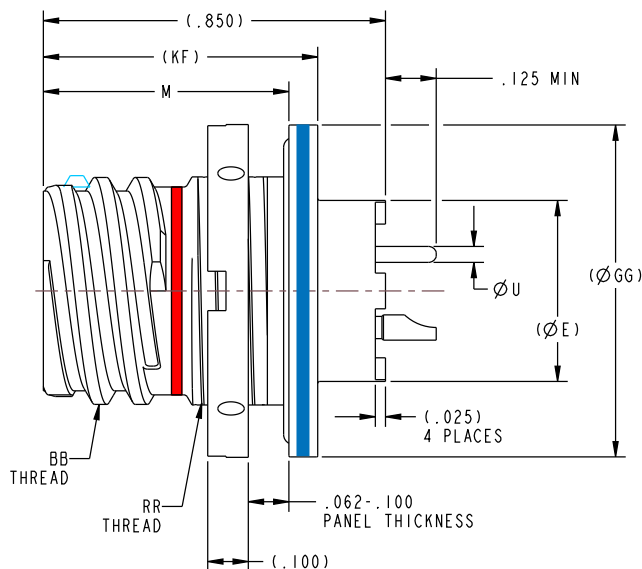
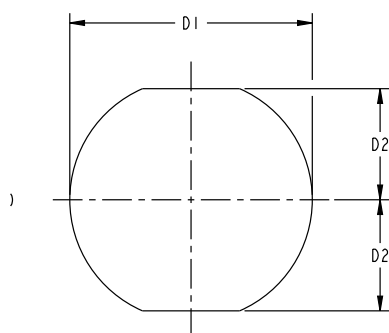

Shell Size	(ØA)	(D1)	(D2)	(ØE)	(M)	BB Thread	(ØGG)	(KF)	RR Thread	ØU Tail Dia
8	.825	.670	.300	.448	.605	.5600-0 .1P-0 .2L - DS-2A	.820	.678	.6250 - 24 - UNEF - 2A	#23 .0260/.0275
10	.975	.800	.360	.594	.605	.6800-0 .1P-0 .2L - DS-2A	.945	.678	.7500 - 20 - UNEF - 2A	#22 .0305/.0295
12	1.096	.920	.420	.718	.605	.8000-0 .1P-0 .2L - DS-2A	1.070	.678	.8750 - 20 - UNEF - 2A	#22D .0305/.0295
14	1.275	1.090	.480	.843	.605	.9200-0 .1P-0 .2L - DS-2A	1.250	.678	1.0000 - 20 - UNEF - 2A	#22M .0305/.0295
16	1.597	1.300	.600	.968	.605	1.1875-0 .1P-0 .2L - DS-2A	1.656	.698	1.2500 - 20 - UNEF - 2A	#20 .0417/.039
18	1.722	1.420	.640	1.066	.605	1.2500-0 .1P-0 .2L - DS-2A	1.755	.698	1.3750 - 20 - UNEF - 2A	#16 .0635/.0615
20	1.847	1.550	.700	1.191	.605	1.3750-0 .1P-0 .2L - DS-2A	1.908	.698	1.5000 - 20 - UNEF - 2A	#12 .095/.093
22	1.972	1.670	.760	1.316	.605	1.5000-0 .1P-0 .2L - DS-2A	2.033	.698	1.6250 - 20 - UNEF - 2A	
24	2.112	1.800	.820	1.441	.605	1.6250-0 .1P-0 .2L - DS-2A	2.158	.698	1.750 - 20 - UNEF - 2A	

*Compatible with all D38999 Series II Accessories

**PCB Mod Codes Only



SERIES FIVE HERMETIC BOX MOUNT S502Y

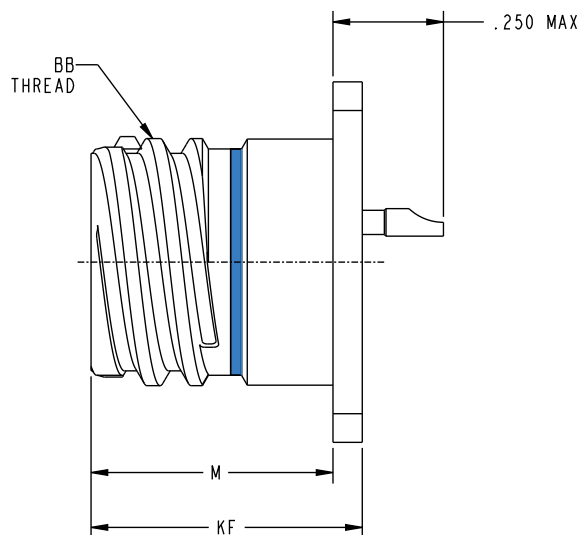
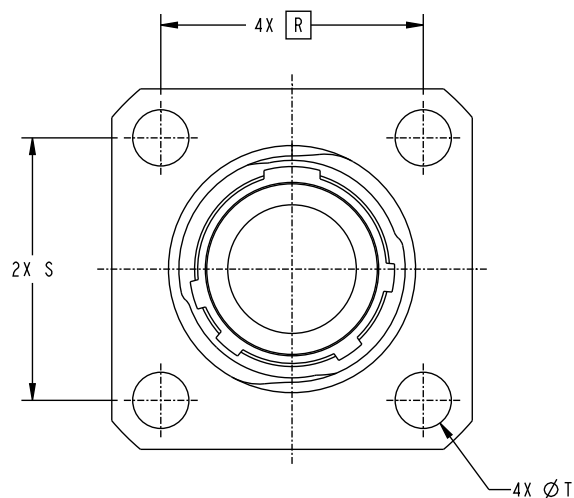

Shell Size	(M)	R	(S)	(ØT)	BB Thread	KF
8	.5475	.594	.815	.128	.5600 - 0 .1P-0 .2L - DS	.613
10	.5475	.719	.941	.128	.6800 - 0 .1P-0 .2L - DS	.613
12	.5475	.812	1.034	.128	.8000 - 0 .1P-0 .2L - DS	.613
14	.5475	.906	1.128	.128	.9200 - 0 .1P-0 .2L - DS	.613
16	.5475	.969	1.222	.128	1.1875 - 0 .1P-0 .2L - DS	.651
18	.5475	1.062	1.315	.128	1.2500 - 0 .1P- 0.2L - DS	.651
20	.5475	1.156	1.441	.128	1.3750 - 0.1P-0 .2L - DS	.651
22	.5475	1.250	1.565	.154	1.5000 - 0.1P-0 .2L - DS	.651
24	.5475	1.375	1.691	.154	1.6250 - 0 .1P-0 .2L - DS	.651

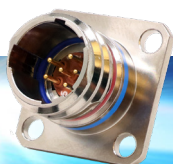

SERIES FIVE MINI-BAND TERMINATION

Mini-band Termination: For assembling cables to overmolded style S5 connectors or backshells, the Mini-band system offers quick termination of cable shields and flexibility to be utilized on a wide range of parts with just one band size. These rugged straps have passed numerous hazardous environmental testing. Including shock and vibration. Approved for use in military and aerospace applications.

MATERIALS:

Mini-band installation tool. Use with .120" (3.05 mm) wide bands, 6.75 inches (172 mm.) length, 1.2 pounds (0.6 Kg.)

Mini-band, .120" (3.05 mm) wide. Available in two lengths, flat or pre-coiled. Stainless steel.



Description	DMC Part Number	Military Part Number
Mini-Band Installation Tool	DBS-2200	M81306/1B

Length		Accommodates Diameter		DMC Part Number	Military Part Number
Inches	mm	inches	mm		
8.125	206.38	.88	22.35	DBS-1287	M85049/128-7



Step 1: Prepare the Connector and Cable Braid

Prepare the connector and cable braid for band termination process (see DMC Website).



Step 2: Prepare Band

Using an appropriate size band, feed the end of the band through the narrow slot on the buckle twice. This will create a double-looped band. Never use a single-looped band. To hasten the termination process on smaller adapters, pull on the end of the band to reduce the diameter of the loop.



Step 3: Insert Looped Band into Tool

Squeeze the release lever and insert the end of the band into the nose of the tool. Ensure the orientation of the band matches the graphic on the body of the tool (coil down when the tool is held upright).

Step 4: Positioning

Position the connector and the shield assembly through the band.

Step 5: Tighten Band around Braid/Connector

Repeatedly squeeze the tensioning handle until the band closes around the assembly. Once the band is closed around the assembly, use half strokes of the handle until the band is tight against the braided cable. Release the tensioning handle and allow it to open fully. With one final stroke, close the tensioning handle until it locks against the tool body. This indicates that the band has been tightened to the pre-set tension.

Step 6: Cut Off

Once the tensioning handle is locked in place, squeeze the cut-off handle to finish the termination process. Both handles will open up on their own. (If shrinkable tubing is to be applied, it is recommended that the band is wrapped in tape and the excess braid folded back over the band to prevent cutting of shrinkable tubing).

Step 7: Remove Excess Band Material

Release the tensioning handle and then squeeze the release lever. While squeezing the release lever, carefully pull on the band and slide it out of the tool and discard.



SERIES FIVE

Assembly Instructions

WIRE STRIPPING

1. Strip wire to required length. (See Figure at right). When using hot wire stripping, do not wipe melted insulation material on wire strands; with mechanical strippers do not cut or nick strands.
 2. See Table 1 for proper finished outside wire dimensions.
 3. Twist strands together to form a firm bundle.
 4. Insert stripped wire into contact applying slight pressure until wire insulation butts against wire well. Check inspection hole to see that wire strands are visible. If there are strayed wire strands, entire wire end should be re-twisted.
- When wire is stripped and properly installed into contact, the next step is to crimp the wire inside the contact by using the proper crimping tool.

STRIPPING DIMENSIONS

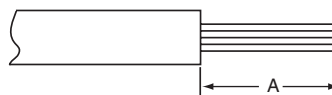

Wire Size	A
22, 22M, 22D	.125 (3.18)
20	.188 (4.77)
16	.188 (4.77)
12	.188 (4.77)

Table 1

Contact Size	Wire Dimension (inches)**	
	Min.	Max.
10	.135	.162
12	.097	.142
16	.065	.109
20	.040	.077
22	.034	.060
22M, 22D	.030	.050

** Min. diameters to insure moisture proof assembly; max. diameters to permit use of metal removal tools.

CRIMPING

See table on preceding page for recommended M22520 series crimping tools, turret head or positioner selection settings according to contact size, part number and wire gauge size.

1. Insert stripped wire into contact crimp pot. Wire must be visible through inspection hole.
2. Using correct crimp tool and locator, cycle the tool once to be sure the indentors are open, insert contact and wire into locator. Squeeze tool handles firmly and completely to insure a proper crimp. The tool will not release unless the crimp indentors in the tool head have been fully actuated.
3. Release crimped contact and wire from tool. Be certain the wire is visible through inspection hole in contact.

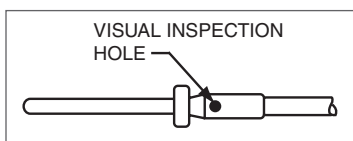

Examples of M22520 Series Crimping Tools:
Shown top: tool used for small size 22, 22D and 22M contacts.
Shown bottom: tool used for size 20, 16 or 12 contacts and has a positioner that can be dialed for each contact size.

CONTACT INSERTION

1. First remove hardware from the plug and receptacle and slide the hardware over wires in proper sequence.

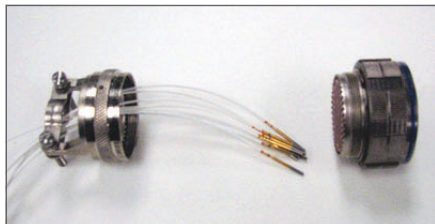

Note: All plastic tools are double-ended. The colored side is the insertion tool and the white side is the removal tool.

2. Use proper plastic or metal insertion tool for corresponding contact. (Consult Insertion Tool table on page 8). Slide correct tool (with plastic tool use colored end) over wire insulation and slide forward until tool bottoms against rear contact shoulder.

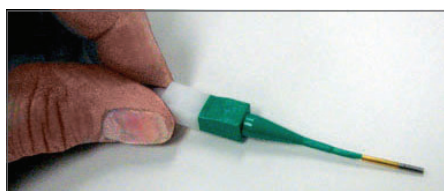

Plastic tool with contact in proper position.



Metal tool with contact.

3. Next align the tool and contact up to the properly identified cavity at rear of connector plug. Use firm, even pressure; do not use excessive pressure. It is recommended to start at the center cavity. Contact must be aligned with grommet hole and not inserted at an angle. Push forward until contact is felt to snap into position within insert.

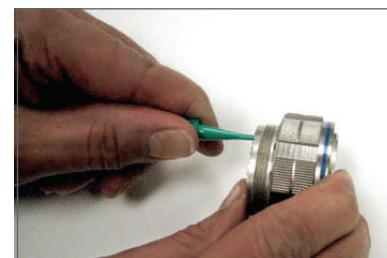

Continued on next page.

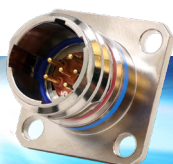

SERIES FIVE

Assembly Instructions, cont.

CONTACT INSERTION, CONT.

4. Remove tool and pull back lightly on wire, making sure contact stays properly seated and isn't dragged back with the tool. Repeat operation with remainder of contacts to be inserted, beginning with the center cavity and working outward in alternating rows.

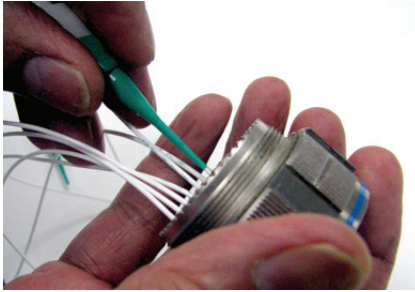

5. After all contacts are inserted, fill any empty cavities with wire sealing plugs. (Refer to sealing plug charts page 8)

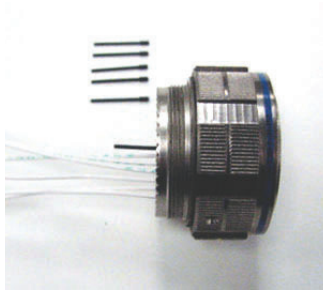

6. Reassemble plug or receptacle hardware - slide forward and tighten using connector pliers. Connector holding tools are recommended while tightening back accessories. When using strain relief, center wires at bar clamp. Slide clamp grommet into position and tighten clamp bar screws. When tightening screws, pressure should be applied in the same direction that clamp is threaded to rear threads of connector. When not using clamp grommet, build up wire bundle with vinyl tape so clamp bar will maintain pressure on wires.



CAUTION, when inserting or removing contacts, do not spread or rotate tool tips.

CONTACT REMOVAL

1. Remove hardware from plug or receptacle and slide hardware back along wire bundle.

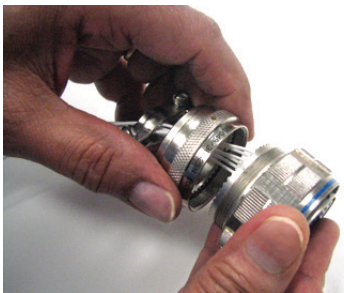

2. Use proper plastic or metal removal tool for corresponding contact. (Consult Removal Tool table on page 8). Slide correct size tool over wire insulation.

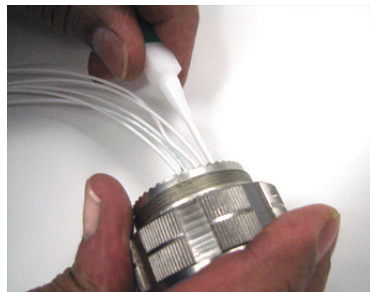

Use white end of plastic tool for removal of contacts.

3. Insert plastic or metal removal tool into contact cavity until tool tips enter rear grommet and come to a positive stop. Hold tool tip firmly against positive stop on contact shoulder. Grip wire and simultaneously remove tool and contact. (On occasion, it may be necessary to remove tool, rotate 90° and reinsert.)

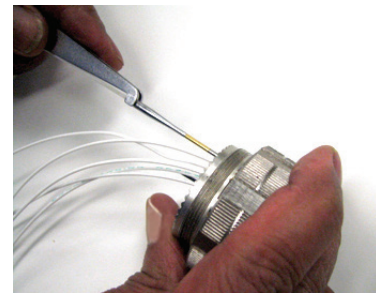

Removal of contacts with metal tool.



BACKSHELLS FROM AMPHENOL PCD

Amphenol holds the leadership position for providing interconnect solutions that meet almost all Military, Aerospace and Industrial standards in the U.S., Europe and Asia.

With design and manufacturing facilities and sales offices spread across the globe, Amphenol offers a vast product portfolio of connectors, cable assemblies and system integration for almost all applications across various industries.

BACKSHELLS

Within Amphenol's wide range of interconnect products is a full range of backshell hardware. Customers can take advantage of Amphenol's global synergy for connectors, backshells and cable harnessing with one place for all their interconnect needs.

Plus, coming to Amphenol for a custom design of a backshell, means that customers benefit from the vast amount of experience this global company has in designing interconnect solutions.



Amphenol . . We Connect the World Together

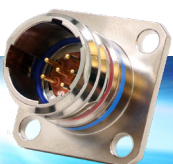

BACKSHELLS

Materials & Finishes, Assembly Torque Values

MATERIALS & FINISHES

Amphenol offers adapters in the following standard finishes. The base material is aluminum alloy.

MATERIAL:
 Aluminum parts: As per ASTM B 211, 221, 209, 85, 26
 Steel parts: 300 series, as per AMS-QQ-S-763/ASTM A 582
 Elastomers: Fluorocarbon, Silicone
 Other parts: Suitable corrosion resistant material

MIL (QPL) QUALIFICATION

Many Amphenol Backshells are qualified to SAE-AS 85049 standard. (Old standard is MIL-C-85049).

TABLE-2 (PLATING FINISHES)

Amphenol Designation	MIL Designation	Finish	Guiding Specifications/Requirements
L		Nickel, Bright	AMS-QQ-290, Class-1, Grade-F
M		Electroless Nickel	AMS-C-26074, Class-4, Grade-B
N	N	Electroless Nickel	To meet AS85049 requirements
U		Cadmium, Olive drab	AMS-QQ-P-416, Type II, Class 3
V		Cadmium, Olive drab over Electroless Nickel	AMS-QQ-P-416, Type-II, Class-3 (Cadmium); AMS-C-26074, Class-4, grade-B (Nickel)
W	W	Cadmium, Olive drab over Electroless Nickel	To meet AS85049 requirements
*	T	Durmalon	
*		AP-93	
*	Z	Black Zinc Nickel	

* Contact Factory

ASSEMBLY TORQUE VALUES

Amphenol recommends the following torque values for its adapters while assembling them to the connectors. These values are based on the coupling thread strength specified in SAE-AS85049 standard.

Connector Shell Size	Torque (Inch-Pounds)
8	40
10	40
12	40
14	40

* Contact Sales@Backshellworld.com for part numbers & availability

STYLE-2 CONFIGURATION

Applications requiring larger diameter cables than the standard shell size; the backshell will be modified to Style-2 as shown in the sketch below. The overall length of the Style-2 backshell will increase by approximately 1 inch (25mm).

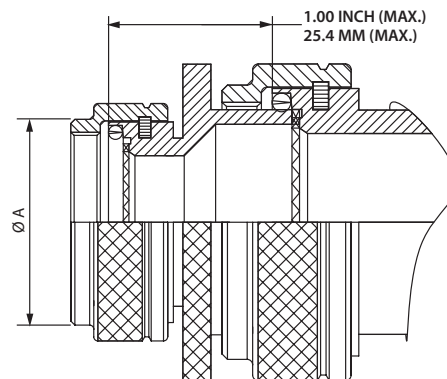

NON-ENVIRONMENTAL BACKSHELL

Straight, Direct Coupling

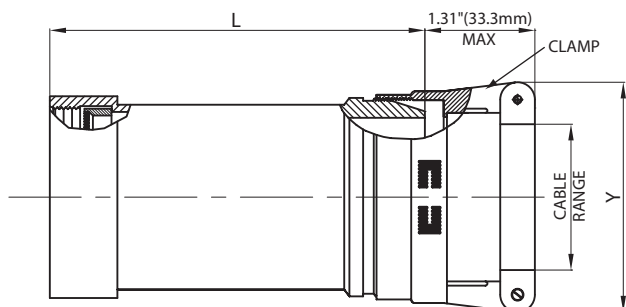

MIL Part Number
M85049 / 29 10 W 02 A

MIL Series: M85049
Slash Sheet: 29: Straight, Direct Coupling
Shell Size: 10
Cable Range: W
Clamp Size: 02
Finish: A
Length: See Table-A (Omit for "STD")
Clamp Size: See Table-A
Finish: See Table-2 (pg. 44)

MIL PART NUMBER DESIGNATOR			CONNECTOR SHELL SIZE SERIES FIVE	CABLE RANGE				L (MAX)		Y (MAX)					
ACCESSORY SHELL SIZE	CLAMP SIZE	LENGTH		MIN		MAX		INCH	MM	INCH	MM				
				INCH	MM	INCH	MM								
08	01	STD.	8	0.06	1.57	0.13	3.18	1.03	26.16	0.78	19.81				
		A						2.03	51.56						
	02	STD.		0.13	3.18	0.25	6.35	1.03	26.16						
		A						2.03	51.56						
10	01	STD.		10	0.06	1.57	0.13	3.18	1.03	26.16	0.78	19.81			
		A							2.03	51.56					
	02	STD.			0.13	3.18	0.25	6.35	1.03	26.16					
		A							2.03	51.56					
	03	STD.	0.25		6.35	0.38	9.53	1.03	26.16						
		A						2.03	51.56						
12	02	STD.	12	0.13	3.18	0.25	6.35	1.03	26.16	0.97	24.64				
		A						2.03	51.56						
	03	STD.		0.25	6.35	0.38	9.53	1.03	26.16						
		A						2.03	51.56						
	04	STD.		0.31	7.92	0.50	12.70	1.03	26.16						
		A						2.03	51.56						
14	02	STD.	14	0.13	3.18	0.25	6.35	1.03	26.16	0.97	24.64				
		A						2.03	51.56						
		B						3.03	76.96						
	03	STD.		0.25	6.35	0.38	9.53	1.03	26.16	2.03	51.56	1.06	26.92		
		A												3.03	76.96
		B													
	04	STD.		0.31	7.92	0.50	12.70	1.03	26.16	2.03	51.56	1.16	29.46		
		A												3.03	76.96
		B													
	05	STD.		0.44	11.10	0.63	15.88	1.03	26.16	2.03	51.56	1.25	31.75		
		A												3.03	76.96
		B													

Note: For more cable entry and length options, email: sales@backshellworld.com
All dimensions for reference only.

**Sizes 16-24 is available, please contact
Amphenol PCD at backshells@amphenolPCD.com**

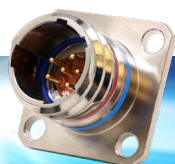

NON-ENVIRONMENTAL EMI/RFI BACKSHELL

Straight, Direct Coupling, Cont.

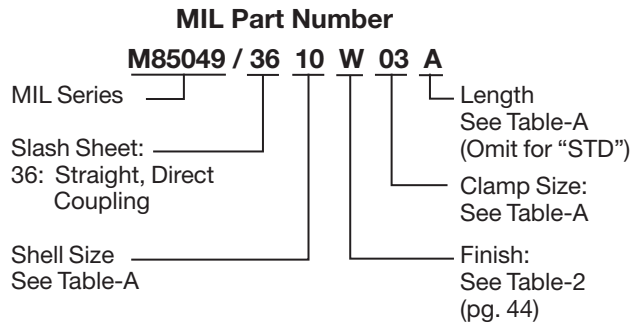
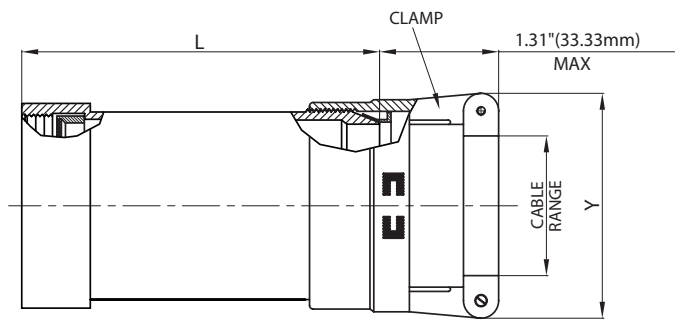

MIL PART NUMBER DESIGNATOR			CONNECTOR SHELL SIZE Series Five	TABLE-A CABLE RANGE				L (MAX)		Y (MAX)				
ACCESSORY SHELL SIZE	CLAMP SIZE	LENGTH CODE		MIN		MAX		INCH	MM	INCH	MM			
				INCH	MM	INCH	MM							
08	01	STD.	8	0.06	1.57	0.13	3.18	1.53	38.86	0.78	19.81			
		A						2.53	64.26					
	02	STD.		0.13	3.18	0.25	6.35	1.53	38.86			0.97	24.64	
		A		2.53	64.26									
10	01	STD.		10	0.06	1.57	0.13	3.18	1.53	38.86	0.78	19.81		
		A							2.53	64.26				
	02	STD.			0.13	3.18	0.25	6.35	1.53	38.86			0.97	24.64
		A			2.53	64.26								
	03	STD.	0.25		6.35	0.38	9.53	1.53	38.86	1.06			26.92	
		A	2.53		64.26									
12	02	STD.	12	0.13	3.18	0.25	6.35	1.53	38.86	0.97	24.64			
		A						2.53	64.26					
	03	STD.		0.25	6.35	0.38	9.53	1.53	38.86			1.06	26.92	
		A		2.53	64.26									
	04	STD.		0.31	7.92	0.50	12.70	1.53	38.86			1.16	29.46	
		A		2.53	64.26									
14	02	STD.	14	0.13	3.18	0.25	6.35	1.53	38.86	0.97	24.64			
		A						2.53	64.26					
		B						3.53	89.66					
	03	STD.		0.25	6.35	0.38	9.53	1.53	38.86	1.06	26.92			
		A		2.53	64.26									
		B		3.53	89.66									
	04	STD.		0.31	7.92	0.50	12.70	1.53	38.86	1.16	29.46			
		A		2.53	64.26									
		B		3.53	89.66									
	05	STD.		0.44	11.10	0.63	15.88	1.53	38.86	1.25	31.75			
		A		2.53	64.26									
		B		3.53	89.66									

Note: For more cable entry and length options, email: sales@backshellworld.com
 All dimensions for reference only.

**Sizes 16-24 is available, please contact
 Amphenol PCD at backshells@amphenolPCD.com**



ENVIRONMENTAL EMI/RFI BACKSHELL

Straight, Direct Coupling

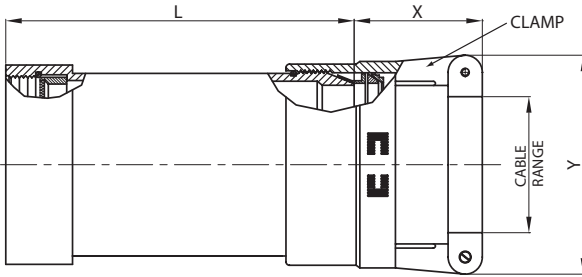

MIL Part Number
M85049 / 17 10 W 03 A

MIL Series ————
Slash Sheet: 17: Straight, Direct Coupling
Shell Size ———— See Table-A

Length See Table-A (Omit for "STD")
Clamp Size: See Table-A
Finish: See Table-2 (pg. 44)

MIL PART NUMBER DESIGNATOR		LENGTH	SHELL SIZE Series Five	CABLE RANGE				L (MAX)		X (MAX)		Y (MAX)		
ACCESSORY SHELL SIZE	CLAMP SIZE			MIN		MAX		INCH	MM	INCH	MM	INCH	MM	
				INCH	MM	INCH	MM							
08	01	STD.	8	0.06	1.57	0.13	3.18	1.53	38.86	1.25	31.75	0.78	19.81	
		A						2.53	64.26					
	02	STD.		0.13	3.18	0.25	6.35	1.53	38.86			0.97	24.64	
		A						2.53	64.26					
10	01	STD.		10	0.06	1.57	0.13	3.18	1.53	38.86	1.25	31.75	0.78	19.81
		A							2.53	64.26				
	02	STD.			0.13	3.18	0.25	6.35	1.53	38.86			0.97	24.64
		A							2.53	64.26				
	03	STD.	0.25		6.35	0.38	9.53	1.53	38.86	1.06			26.92	
		A						2.53	64.26					
12	02	STD.	12		0.13	3.18	0.25	6.35	1.53	38.86	1.25	31.75	0.97	24.64
		A							2.53	64.26				
	03	STD.			0.25	6.35	0.38	9.53	1.53	38.86			1.06	26.92
		A							2.53	64.26				
	04	STD.			0.38	9.53	0.50	12.70	1.53	38.86			1.16	29.46
		A							2.53	64.26				
14	02	STD.		14	0.13	3.18	0.25	6.35	1.53	38.86	1.25	31.75	0.97	24.64
		A							2.53	64.26				
		B							3.53	89.66				
	03	STD.			0.25	6.35	0.38	9.53	1.53	38.86			1.06	26.92
		A							2.53	64.26				
		B							3.53	89.66				
	04	STD.	0.38		9.53	0.50	12.70	1.53	38.86	1.16			29.46	
		A						2.53	64.26					
		B						3.53	89.66					
	05	STD.	0.50		12.70	0.63	15.88	1.53	38.86	1.25			31.75	
		A						2.53	64.26					
		B						3.53	89.66					

Note: For more cable entry and length options, email: sales@backshellworld.com
All dimensions for reference only.

Sizes 16-24 is available, please contact Amphenol PCD at backshells@amphenolPCD.com

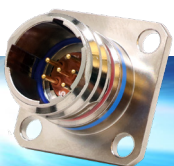

ENVIRONMENTAL EMI/RFI BACKSHELL

90° and 45°, Spin Coupling

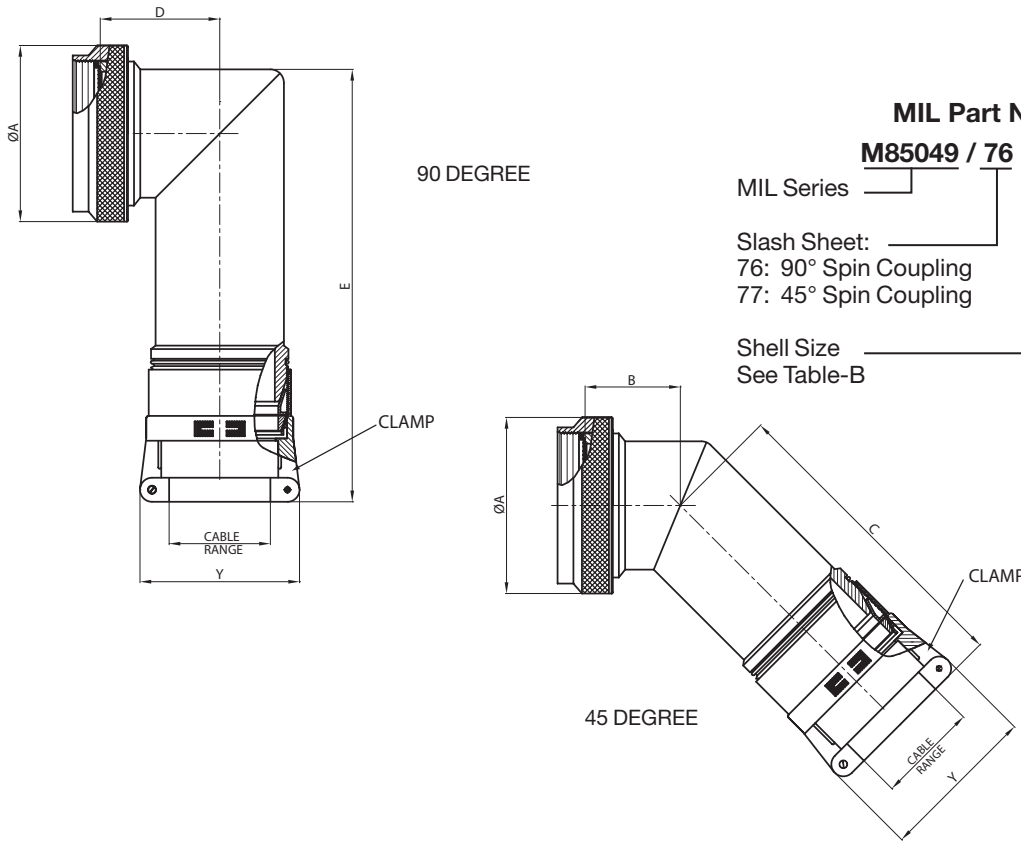

MIL Part Number

M85049 / 76 10 W 01

MIL Series

Slash Sheet:
76: 90° Spin Coupling
77: 45° Spin Coupling

Shell Size
See Table-B

Clamp Size:
See Table-B

Finish:
See Table-2
(pg. 44)

TABLE - B

MIL PART NUMBER DESIGNATOR		SHELL SIZE Series Five	CABLE RANGE				A DIA. (MAX)		B (MAX)		C (MAX)		D (MAX)		E (MAX)		Y (MAX)	
ACCESSORY SHELL SIZE	CLAMP SIZE		MIN		MAX		INCH	MM	INCH	MM	INCH	MM	INCH	MM	INCH	MM	INCH	MM
			INCH	MM	INCH	MM												
08	01	8	0.06	1.57	0.13	3.18	0.75	19.05	0.46	11.68	3.15	80.01	0.69	17.53	3.46	87.88	0.80	20.32
	02		0.13	3.18	0.25	6.35											1.00	25.40
10	01	10	0.06	1.57	0.13	3.18	0.85	21.59	0.52	13.21	3.21	81.53	0.78	19.81	3.58	90.93	0.80	20.32
	02		0.13	3.18	0.25	6.35											1.00	25.40
	03		0.25	6.35	0.38	9.53											1.10	27.94
12	02	12	0.13	3.18	0.25	6.35	1.00	25.40	0.58	14.73	3.27	83.06	0.80	20.32	3.60	91.44	1.00	25.40
	03		0.25	6.35	0.38	9.53											1.10	27.94
	04		0.38	9.53	0.50	12.70											1.20	30.48
14	02	14	0.13	3.18	0.25	6.35	1.15	29.21	0.65	16.51	3.36	85.34	0.88	22.35	3.67	93.22	1.00	25.40
	03		0.25	6.35	0.38	9.53											1.10	27.94
	04		0.38	9.53	0.50	12.70											1.20	30.48
	05		0.50	12.70	0.63	15.88											1.25	31.75
16	02	16	0.13	3.18	0.25	6.35	1.25	29.21	0.65	16.51	3.36	85.34	0.88	22.35	3.67	93.22	1.00	25.40
	03		0.25	6.35	0.38	9.53											1.10	27.94
	04		0.38	9.53	0.50	12.70											1.20	30.48
	05		0.50	12.70	0.63	15.88											1.25	31.75
	06		0.63	15.88	0.75	19.05											1.40	35.56

Note: For more cable entry and length options, email: sales@backshellworld.com
All dimensions for reference only.

Sizes 16-24 is available, please contact
Amphenol PCD at backshells@amphenolPCD.com



ENVIRONMENTAL EMI/RFI BACKSHELL, CONTI

90° and 45°, Spin Coupling

TABLE – B

MIL PART NUMBER DESIGNATOR		SHELL SIZE Series Five	CABLE RANGE				A DIA. (MAX)		B (MAX)		C (MAX)		D (MAX)		E (MAX)		Y (MAX)			
ACCESSORY SHELL SIZE	CLAMP SIZE		MIN		MAX		INCH	MM	INCH	MM	INCH	MM	INCH	MM	INCH	MM	INCH	MM		
			INCH	MM	INCH	MM														
18	03	18	0.25	6.35	0.38	9.53	1.40	35.56	0.93	23.62	3.66	92.96	1.01	25.65	3.93	99.82	1.10	27.94		
	04		0.38	9.53	0.50	12.70													1.20	30.48
	05		0.50	12.70	0.63	15.88													1.25	31.75
	06		0.63	15.88	0.75	19.05													1.40	35.56
	07		0.75	19.05	0.88	22.23													1.50	38.10
20	03	20	0.25	6.35	0.38	9.53	1.55	39.37	0.93	23.62	3.66	92.96	1.06	26.92	3.93	99.82	1.10	27.94		
	04		0.38	9.53	0.50	12.70													1.20	30.48
	05		0.50	12.70	0.63	15.88													1.25	31.75
	06		0.63	15.88	0.75	19.05													1.40	35.56
	07		0.75	19.05	0.88	22.23													1.50	38.10
	08		0.88	22.23	1.00	25.40													1.65	41.91
24	03	24	0.25	6.35	0.38	9.53	1.55	39.37	0.93	23.62	3.66	92.96	1.06	26.92	3.93	99.82	1.10	27.94		
	04		0.38	9.53	0.50	12.70													1.20	30.48
	05		0.50	12.70	0.63	15.88													1.25	31.75
	06		0.63	15.88	0.75	19.05													1.40	35.56
	07		0.75	19.05	0.88	22.23													1.50	38.10
	08		0.88	22.23	1.00	25.40													1.65	41.91
	09		1.00	25.40	1.13	28.58													1.75	44.45

SHRINK BOOT ADAPTER

Straight, Spin Coupling

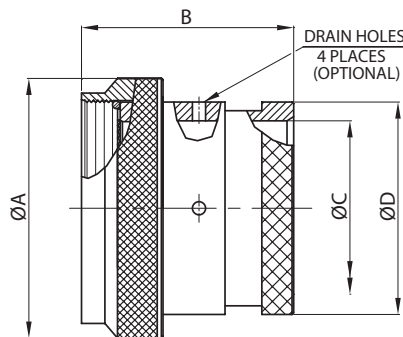

MIL Part Number

M85049 / 62 10 W D

MIL Series _____
 Slash Sheet: _____
 62: Straight, Spin Coupling

D: Drain hole Option
 Finish: See Table-2 (pg. 44)
 Dash Number: See Table-A

TABLE-A

MIL PART NUMBER DESIGNATOR	CONNECTOR SHELL SIZE Series Five	A DIA. (MAX)		B (MAX)		C DIA. (MIN)		D DIA. (MAX)	
		INCH	MM	INCH	MM	INCH	MM	INCH	MM
08	8	0.75	19.05	1.00	25.40	0.25	6.35	0.53	13.54
10	10	0.85	21.59	1.00	25.40	0.38	9.53	0.61	15.37
12	12	1.00	25.40	1.00	25.40	0.50	12.70	0.77	19.66
14	14	1.10	27.94	1.00	25.40	0.63	15.88	0.84	21.29

Note: For more cable entry and length options, email: sales@backshellworld.com
 All dimensions for reference only.

Sizes 16-24 is available, please contact Amphenol PCD at backshells@amphenolPCD.com

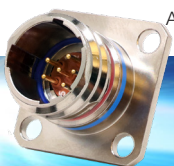

CRIMP RING ADAPTER

Straight, Spin Coupling

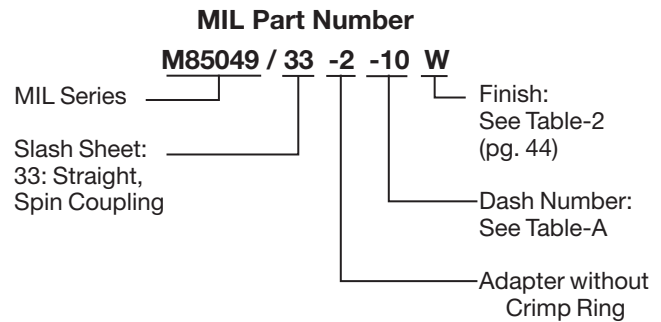
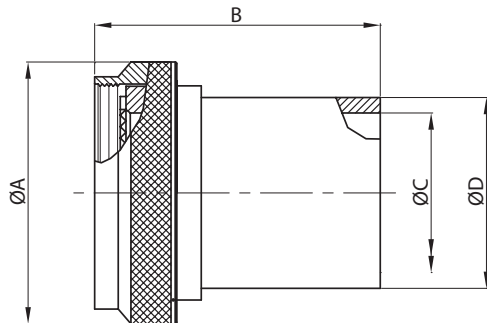

TABLE - A						
MIL PART NUMBER DESIGNATOR	A DIA.(MAX)		B (MAX)		C DIA.(MAX)	
	INCH	MM	INCH	MM	INCH	MM
08	0.75	19.05	0.27	6.73	0.35	8.81
10	0.85	21.59	0.34	8.71	0.50	12.65
12	1.00	25.40	0.44	11.10	0.51	12.95
14	1.10	27.94	0.56	14.27	0.63	16.00
16	1.25	31.75	0.69	17.45	0.76	19.30
18	1.40	35.56	0.81	20.62	0.89	22.61
20	1.50	38.10	0.94	23.80	1.01	25.65
22	1.65	41.91	1.05	26.57	1.13	28.70
24	1.75	44.45	1.13	28.58	1.20	30.53

Note: For more cable entry and length options, email: sales@backshellworld.com
All dimensions for reference only.



BAND LOCK ADAPTER

Straight, 90° and 45° Self-Lock

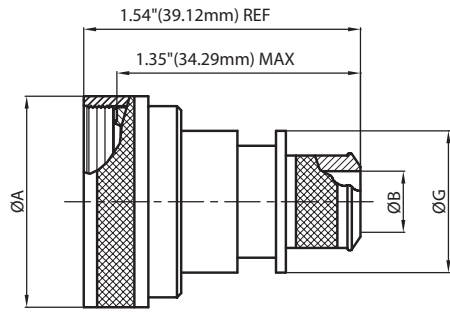

STRAIGHT

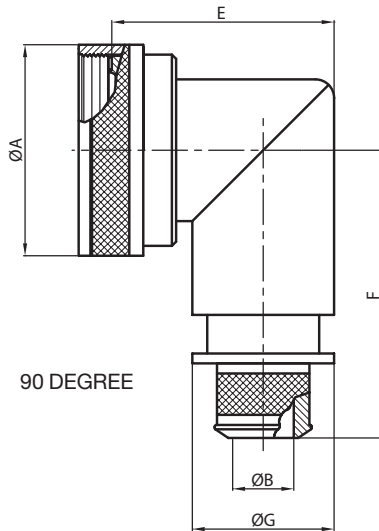

90 DEGREE

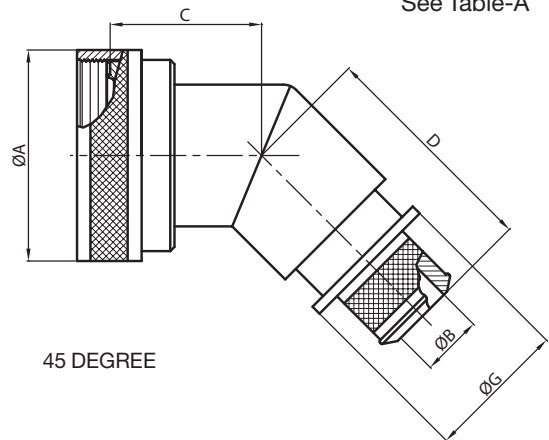

45 DEGREE

MIL Part Number

M85049 / 85 -10 W 02

MIL Series: M85049 / 85
 Slash Sheet: 85: Straight, Self-Lock; 87: 90°, Self-Lock; 86: 45°, Self-Lock
 Entry Size: See Table-A
 Finish: See Table-2 (pg. 44)
 Shell Size: See Table-A

TABLE-A

MIL PART NUMBER DESIGNATOR		SHELL SIZE Series Five	A DIA. (MAX)		B DIA. (MAX)		C (MAX)		D (MAX)		E (MAX)		F (MAX.)		G MAX	
ACCESSORY SHELL SIZE	ENTRY SIZE		INCH	MM	+0.00	+0.00	INCH	MM	INCH	MM	INCH	MM	INCH	MM	INCH	MM
					-0.02	-0.50										
08	03	8	0.86	21.82	0.26	6.60	0.87	22.10	1.16	29.46	1.38	34.93	1.42	35.99	0.56	14.22
10	03	10	0.99	25.04	0.32	8.13	0.90	22.86	1.19	30.23	1.44	36.50	1.48	37.59	0.63	16.00
12	02	12	1.16	29.36	0.32	8.13	0.92	23.37	1.21	30.73	1.56	39.67	1.55	39.45	0.63	16.00
	03				0.45	11.43									0.75	19.05
14	02	14	1.28	32.54	0.45	11.43	0.95	24.13	1.24	31.50	1.69	42.85	1.61	41.00	0.75	19.05
	03				0.57	14.48									0.89	22.61
16	02	16	1.39	35.18	0.51	8.13	0.98	24.89	1.26	32.00	1.75	44.45	1.68	42.62	0.82	20.83
	03				0.64	11.43									0.95	24.13
18	02	18	1.51	38.35	0.64	16.26	0.98	24.89	1.27	32.26	1.88	47.63	1.77	45.03	0.95	24.13
	03				0.76	19.30									1.07	27.18
20	02	20	1.64	41.53	0.64	16.26	1.01	25.65	1.30	33.02	1.94	49.23	1.80	45.62	0.95	24.13
	03				0.82	20.83									1.13	28.07
22	02	22	1.76	44.70	0.70	17.78	1.04	26.42	1.33	33.78	2.06	52.37	1.86	47.22	1.02	25.99
	03				0.95	24.13									1.26	32.00
24	02	24	1.89	48.03	0.76	19.30	1.07	27.18	1.35	34.29	2.13	53.98	1.92	48.74	1.07	27.18
	03				1.01	25.65									1.32	33.53

Note: For more cable entry and length options, email: sales@backshellworld.com
 All dimensions for reference only.

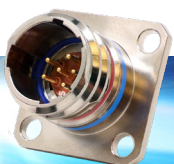

PRE-SHIELD ADAPTER

Straight, 90° Spin Coupling/Self-lock

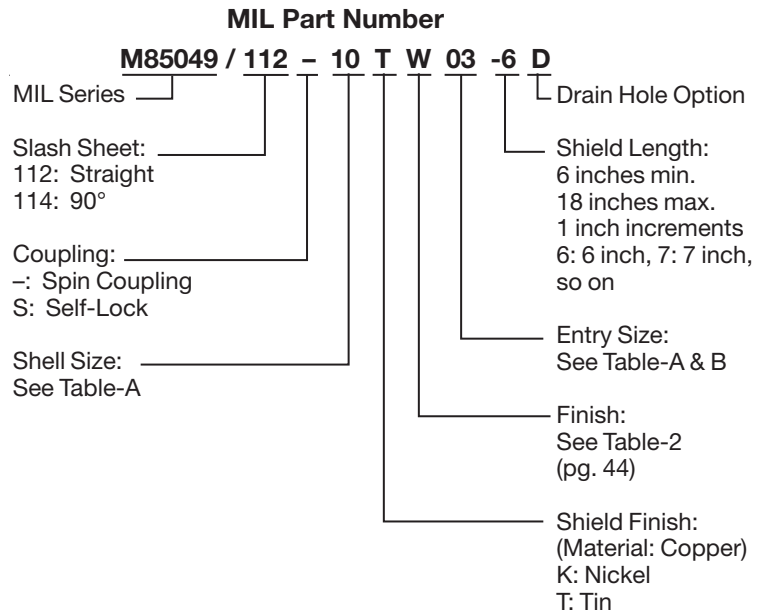
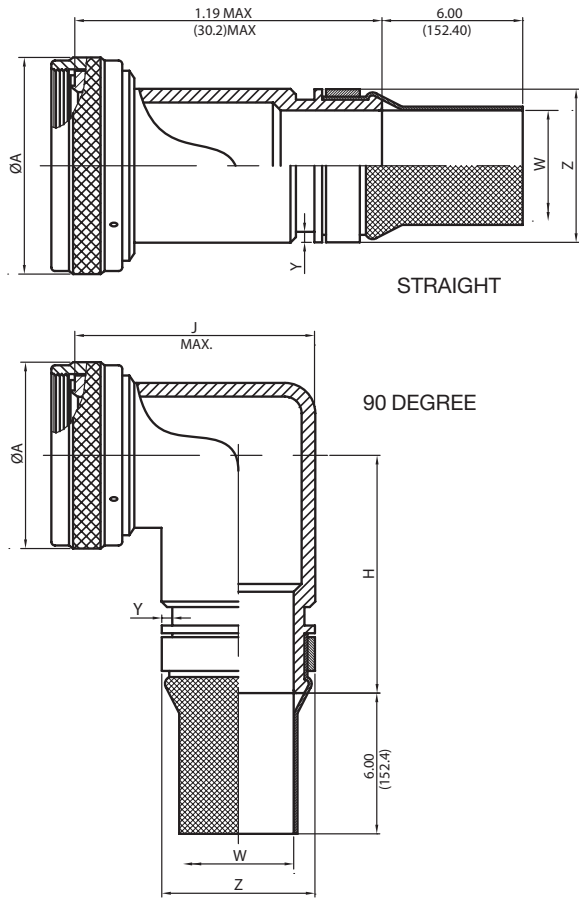

MIL PART NUMBER DESIGNATOR		SHELL SIZE Series Five	A DIA.(MAX)		H (MAX)		J (MAX)	
ACCESSORY SHELL SIZE	ALLOWABLE ENTRY SIZE		INCH	MM	INCH	MM	INCH	MM
08	- 01	8	0.860	21.84	1.73	43.94	1.07	27.18
10	01 03	10	0.980	24.89	1.85	46.99	1.19	30.23
12	01 05	12	1.160	29.46	1.87	47.50	1.32	33.53
14	03 07	14	1.280	32.51	1.94	49.28	1.44	36.58

ENTRY SIZE	W ±0.020	W ±0.508	Y +0.008 -0.000	Y +0.200 -0.000	Z MAX	Z MAX
	INCH	MM	INCH	MM	INCH	MM
01	0.250	6.350	0.044	1.12	0.56	14.22
02	0.312	7.920	0.044	1.12	0.63	16.00
03	0.375	9.530	0.044	1.12	0.69	17.53
04	0.438	11.130	0.044	1.12	0.75	19.05
05	0.500	12.700	0.044	1.12	0.82	20.83
06	0.562	14.270	0.044	1.12	0.89	22.61
07	0.625	15.880	0.044	1.12	0.95	24.13
08	0.688	17.480	0.044	1.12	1.02	25.91
09	0.750	19.050	0.069	1.75	1.07	27.18
10	0.812	20.620	0.069	1.75	1.13	28.70
11	0.875	22.230	0.069	1.75	1.19	30.23
12	0.938	23.830	0.069	1.75	1.26	32.00
13	1.000	25.400	0.069	1.75	1.32	33.53
14	1.125	28.575	0.069	1.75	1.47	37.34

Note: For more cable entry and length options, email: sales@backshellworld.com
 All dimensions for reference only.

Sizes 16-24 is available, please contact Amphenol PCD at backshells@amphenolPCD.com



TIE WRAP BACKSHELL

Straight, 90° and 45° Self-Lock/Non Self-Lock

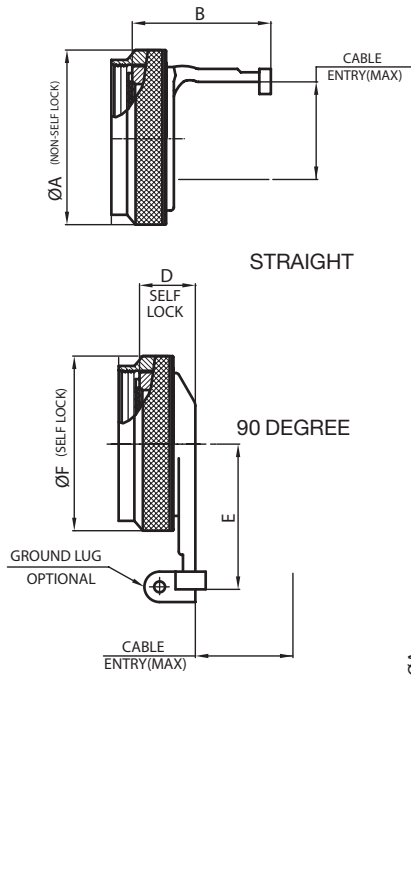

MIL Part Number
M85049 / 56 - 10 W

MIL Series: 56: Straight, 63: 90°, 57: 45°

Finish: See Table-2 (pg. 44)

Dash Number: See Table-A

Coupling:
S: Self-Lock (only for 90° and 45°)
G: Self-Lock with grounding Lug (only for 90° and 45°)
-: Non Self-Lock

TABLE - A															
MIL PART NUMBER DESIGNATOR	SHELL SIZE Series Five	A DIA.(MAX)		B (MAX)		C (MAX)		D (MAX)		E (MAX)		F DIA.(MAX)		CABLE ENTRY MAX	
		INCH	MM	INCH	MM	INCH	MM	INCH	MM	INCH	MM	INCH	MM	INCH	MM
8	8	0.66	16.69	0.95	24.23	1.23	31.29	0.73	18.54	1.22	30.99	0.89	22.48	0.26	6.60
10	10	0.78	19.86	0.95	24.23	1.23	31.29	0.73	18.54	1.29	32.77	1.01	25.65	0.37	9.27
12	12	0.94	23.80	0.95	24.23	1.23	31.29	0.73	18.54	1.62	41.15	1.14	28.83	0.50	12.73
14	14	1.05	26.67	1.20	30.58	1.23	31.29	0.73	18.54	1.66	42.16	1.26	32.00	0.58	14.61

Note: For more cable entry and length options, email: sales@backshellworld.com
All dimensions for reference only.

Sizes 16-24 is available, please contact Amphenol PCD at backshells@amphenolPCD.com

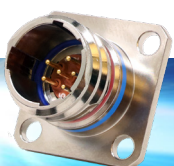

STRAIN RELIEF CLAMP

90° Self-Lock/Spin

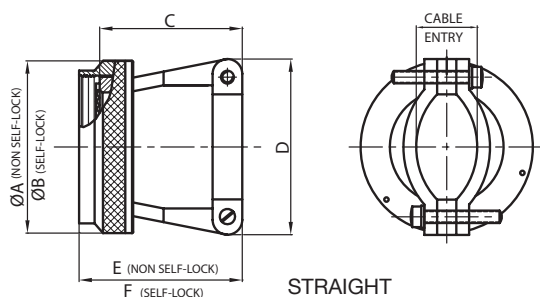

STRAIGHT

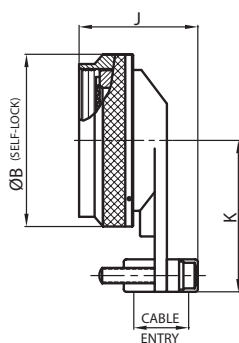

90 DEGREE

MIL Part Number

M85049 / 47 S W 10

MIL Series: _____
 Slash Sheet: 47: 90°
 Dash Number: See Table-A
 Finish: See Table-2 (pg. 44)
 Coupling: S: Self-Lock, Omit: for Spin

TABLE – A

MIL PART NUMBER DESIGNATOR	SHELL SIZE Series Five	A DIA.(MAX)		B DIA.(MAX)		C (MAX)		D (MAX)		E (MAX)		F (MAX)	
		INCH	MM	INCH	MM	INCH	MM	INCH	MM	INCH	MM	INCH	MM
08	8	0.75	19.05	0.86	21.82	0.91	23.11	0.85	21.59	1.10	27.94	1.15	29.21
10	10	0.85	21.59	0.98	24.99	0.91	23.11	0.90	22.86	1.10	27.94	1.15	29.21
12	12	1.00	25.40	1.16	29.36	1.01	25.65	1.10	27.94	1.20	30.48	1.25	31.75
14	14	1.10	27.94	1.28	32.54	1.06	26.92	1.15	29.21	1.25	31.75	1.30	33.02

TABLE – A, cont.

MIL PART NUMBER DESIGNATOR	SHELL SIZE Series Five	J (MAX)		K (MAX)		CABLE ENTRY			
		INCH	MM	INCH	MM	MIN		MAX	
						INCH	MM	INCH	MM
08	8	1.38	35.05	1.00	25.40	0.10	2.49	0.23	5.94
10	10	1.38	35.05	1.10	27.94	0.15	3.89	0.23	5.94
12	12	1.46	37.08	1.10	27.94	0.19	4.83	0.33	8.33
14	14	1.63	41.40	1.25	31.75	0.26	6.60	0.46	11.61

Note: For more cable entry and length options, email: sales@backshellworld.com
 All dimensions for reference only.

Sizes 16-24 is available, please contact Amphenol PCD at backshells@amphenolPCD.com



STRAIN RELIEF CLAMP

Straight, Self-Lock/Non Self-Lock

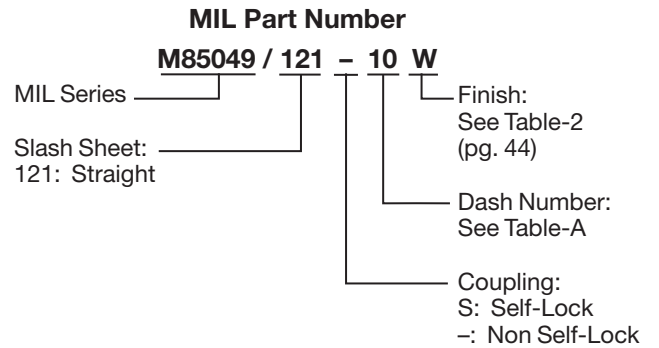
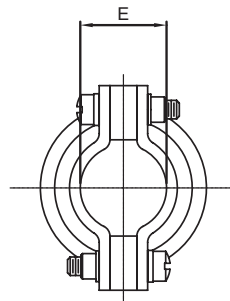
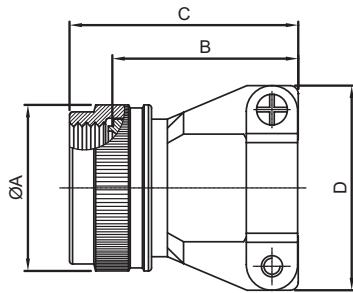
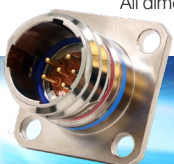

TABLE - A											
MIL PART NUMBER DESIGNATOR	CONNECTOR SHELL SIZE Series Five	A DIA.(MAX)		B LENGTH		C (MAX)		D (MAX)		E (CLOSED)	
		INCH	MM	INCH	MM	INCH	MM	INCH	MM	±.031	±.787
08	08	0.86	21.79	0.77/0.51	19.56/12.95	1.01	25.65	0.88	22.35	0.22	5.56
10	10	0.98	24.99	0.89/0.64	22.61/16.26	1.13	28.70	0.94	23.88	0.26	6.71
12	12	1.16	29.39	1.01/0.76	25.65/19.30	1.25	31.75	1.12	28.45	0.34	8.74
14	14	1.28	32.49	1.01/0.76	25.65/19.30	1.25	31.75	1.19	30.23	0.46	11.68

Sizes 16-24 is available, please contact
Amphenol PCD at backshells@amphenolPCD.com

Note: For more cable entry and length options, email: sales@backshellworld.com
All dimensions for reference only.



STRAIN RELIEF CLAMP

90° Self-Lock/Non Self-Lock

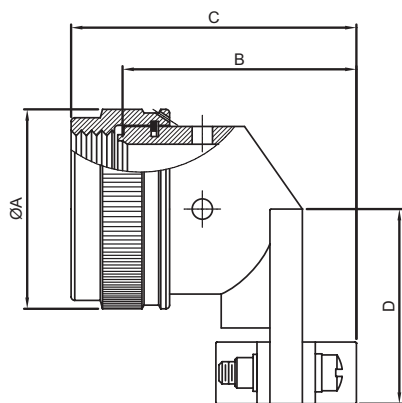

90 DEGREE

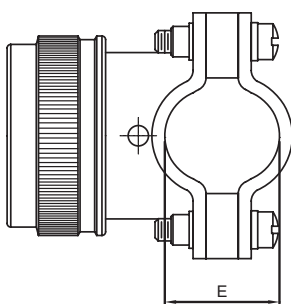

MIL Part Number

M85049 / 123 - 10 W

MIL Series

Slash Sheet:

123: 90°

Finish:
See Table-2
(pg. 44)

Dash Number:
See Table-A

Coupling:
S: Self-Lock
-: Non Self-Lock

TABLE - A

MIL PART NUMBER DESIGNATOR	CONNECTOR SHELL SIZE Series Five	A DIA.(MAX)		B (MAX)		C (MAX)		D (MAX)		E (CLOSED)	
		INCH	MM	INCH	MM	INCH	MM	INCH	MM	±.031	±.787
DASH NO											
08	08	0.86	21.79	0.86	21.84	1.10	27.94	0.81	20.57	0.22	5.56
10	10	0.98	24.99	0.94	23.88	1.18	29.97	0.87	22.10	0.26	6.71
12	12	1.16	29.39	1.14	28.96	1.38	35.05	0.93	23.62	0.34	8.74
14	14	1.28	32.49	1.20	30.48	1.44	36.58	0.99	25.15	0.46	11.68

Sizes 16-24 is available, please contact
Amphenol PCD at backshells@amphenolPCD.com

Note: For more cable entry and length options, email: sales@backshellworld.com
All dimensions for reference only.



GROMMET NUT

Straight, Self-Lock/Non Self-Lock

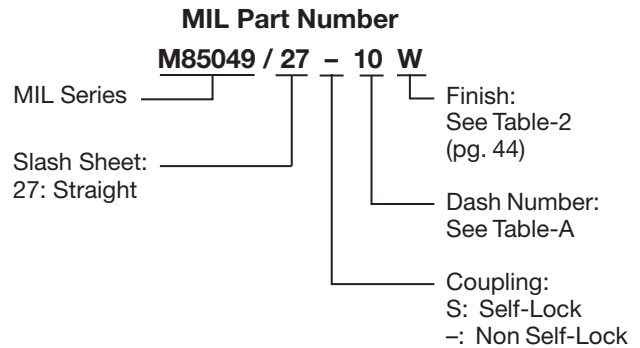
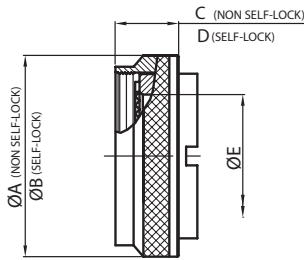

Note: * Slot shown in figure is optional for Non Self-Lock

TABLE-A											
MIL PART NUMBER DESIGNATOR	CONNECTOR SHELL SIZE Series Five	A DIA. (MAX)		B DIA. (MAX)		C (MAX)		D (MAX)		E DIA. (MAX)	
		INCH	MM	INCH	MM	INCH	MM	INCH	MM	INCH	MM
DASH NO.											
08	8	0.75	19.05	0.86	21.82	0.54	13.72	0.59	14.99	0.27	6.86
10	10	0.85	21.59	0.98	24.99	0.54	13.72	0.59	14.99	0.41	10.41
12	12	1.00	25.40	1.16	29.36	0.54	13.72	0.59	14.99	0.53	13.46
14	14	1.10	27.94	1.28	32.54	0.54	13.72	0.59	14.99	0.65	16.51

Note: For more cable entry and length options, email: sales@backshellworld.com
 All dimensions for reference only.

Sizes 16-24 is available, please contact Amphenol PCD at backshells@amphenolPCD.com

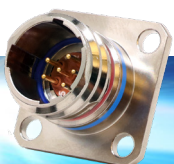

ALUMALIGHT

Ideal Where Lightweight Connector Support Is Needed



- Commercial lightweight metal backshells
- Comparable in weight, performance & price to composite
- Meets or exceed MIL AS85049 standard functionality
- Available in the following backshell families
 - Environmental
 - EMI/RFI Strain Relief
 - EMI/RFI Band Lock

	Metal	Composites	AlumaLight
Mil-Standard & Performance	X	X	X
Strength & Durability	X		X
Reliability	X		X
Lightweight		X	X
EMI Shielding	X		X
Environmental	X		X
Strain Relief	X	X	X



ALUMALIGHT

Environmental

BEL1	S	S	K	10	03	3	C	W
	ANGLE	COUPLE	CONNEC-TOR GROUP	SHELL SIZE	ENTRY SIZE			FINISH
BASIC PART #	S: STRAIGHT	S: SELF LOCK	K: SERIES FIVE	TABLE A	TABLE B	STANDARD LENGTH & FIGURE	C: CLAMP N: NUT	W: Cadmium N: Electroless Nickel Z: Black Zinc Nickel

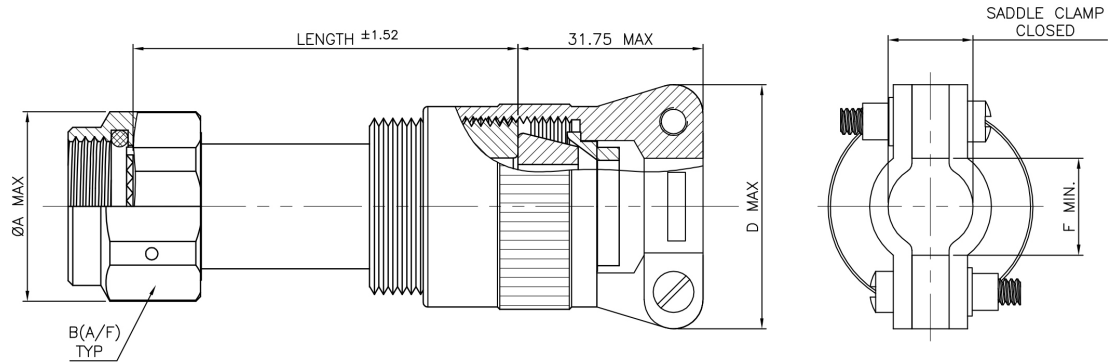
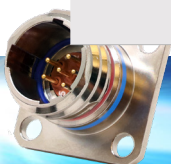

TABLE-A				
SHELL SIZE	LENGTH CODE	ØA MAX.	B HEX	MAX. ENTRY SIZE
08	1	20.40	16.99/17.42	02
	2			
10	1	21.79	18.69/19.05	03
	2			
12	1	24.99	21.84/22.23	04
	2			
14	1	29.39	24.89/25.40	05
	2			
	3			
16	1	32.51	28.58/27.94	06
	2			
	3			
18	1	35.71	31.09/31.75	07
	2			
	3			
20	1	38.51	34.24/34.93	07
	2			
	3			
22	1	41.51	37.31/38.10	08
	2			
	3			
24	1	44.91	40.16/41.28	10
	2			
	3			

TABLE-A					
ENTRY SIZE	Cable Range		Saddle Clamp Closed ± 0.78	D MAX.	F MIN.
	INCH	MM			
02	3.18	6.35	6.70	23.90	6.90
03	6.35	9.53	8.70	28.40	9.53
04	7.92	12.70	11.70	30.20	12.70
05	11.1	15.88	15.70	39.60	15.88
06	14.27	19.05	17.70	42.90	19.05
07	17.45	22.23	19.80	44.50	22.23
08	20.62	25.40	21.60	47.80	25.40
09	23.80	28.58	25.30	63.50	28.58
10	26.97	31.75	31.00	68.10	31.75



ALUMALIGHT

Strain Relief EMI/RFI

BML1	S	S	K	10	W
	ANGLE	COUPLE	CONNECTOR GROUP	SHELL SIZE	FINISH
BASIC PART #	S: STRAIGHT A: 90	S: SELF LOCK	K: SERIES FIVE	TABLE A	W: Cadmium N: Electroless Nickel Z: Black Zinc Nickel

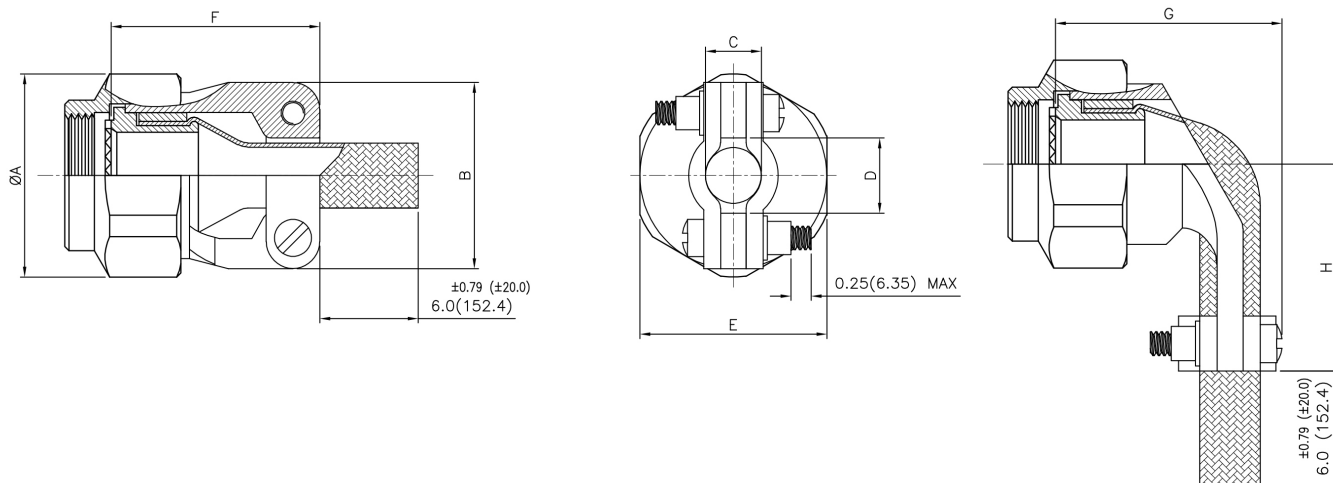

ENTRY SIZE	ØA MAX.		B MAX.		C		D MIN.		E HEX		F		G MAX.		H MAX.	
	INCH	MM	INCH	MM	0.031	0.78	INCH	MM	INCH	MM	INCH	MM	INCH	MM	INCH	MM
					INCH	MM										
08	0.858	21.79	0.880	22.40	0.219	5.60	0.220	5.60	0.750/ 0.736	19.05/ 18.69	0.939/ 0.780	23.85 19.81	1.128	28.65	0.940	23.88
10	0.984	24.99	0.940	23.90	0.264	6.70	0.270	6.90	0.875/ 0.860	22.23/ 21.84	1.059/ 0.860	26.90/ 21.84	1.168	29.67	1.000	25.40
12	1.157	29.39	1.120	28.40	0.344	8.70	0.350	8.90	1.000/ 0.980	25.40/ 24.89	1.199/ 0.950	30.45/ 24.10	1.248	31.70	1.120	27.69
14	1.280	32.51	1.190	30.20	0.460	11.70	0.470	11.90	1.125/ 1.100	28.58/ 27.94	1.199/ 0.950	30.45 24.13	1.368	34.75	1.190	30.23
16	1.406	35.71	1.440	36.60	0.540	13.72	0.550	14.00	1.250/ 1.224	31.75/ 31.09	1.329/ 1.080	33.75/ 27.43	1.448	36.78	1.370	34.89
18	1.516	38.51	1.560	39.60	0.620	15.75	0.620	15.70	1.375/ 1.348	34.93/ 34.24	1.509/ 1.140	38.33/ 28.43	1.528	38.61	1.440	36.58
20	1.642	41.51	1.690	42.90	0.695	17.65	0.700	17.80	1.500/ 1.469	38.10/ 37.31	1.609/ 1.200	40.87/ 30.50	1.648	41.86	1.560	39.67
22	1.768	44.91	1.750	44.50	0.780	19.80	0.780	19.80	1.625/ 1.581	41.28/ 40.16	1.759/ 1.330	44.68/ 33.80	1.688	42.88	1.690	42.85
24	1.890	48.01	1.880	47.80	0.850	21.60	0.850	21.60	1.750/ 1.690	44.45/ 42.93	1.859/ 1.450	47.22/ 42.93	1.758	44.65	1.810	46.02



ALUMALIGHT

Band Lock EMI/RFI

BLL1	S	S	K	10	03	3	C	W	S
	ANGLE	COUPLE	CONNECTOR GROUP	SHELL SIZE	ENTRY SIZE			FINISH	SLOT
BASIC PART #	S: STRAIGHT A: 90 B: 45	S: SELF LOCK	K: SERIES FIVE	TABLE A	TABLE A	STANDARD LENGTH & FIGURE	B: W/BAND X: W/OUT BAND	W: Cadmium N: Electroless Nickel Z: Black Zinc Nickel	(Omit for none)

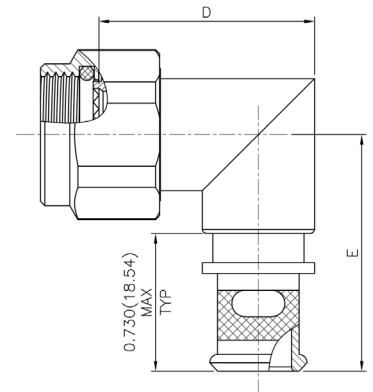
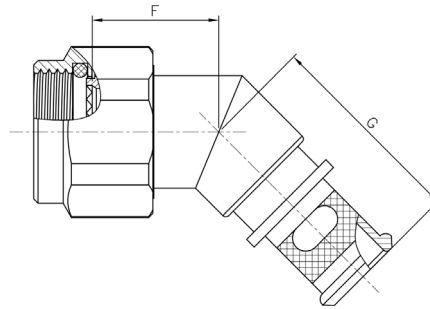
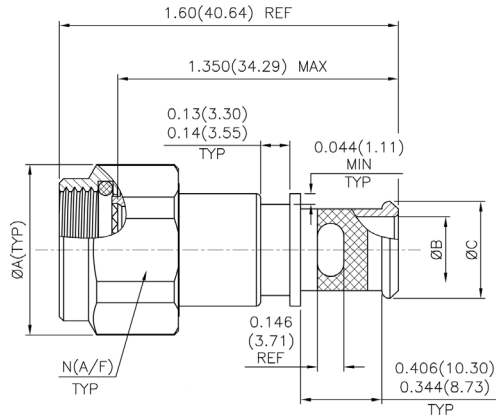
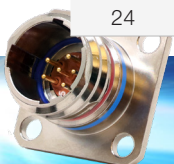

TABLE-A

SHELL SIZE	ØA MAX		N HEX		B				C REF.				D MAX.	
					02		03		02		03			
	INCH	MM	INCH	MM	INCH	MM	INCH	MM	INCH	MM	INCH	MM	INCH	MM
					+ 0.025 - 0.010	+ 0.635 - 0.254	+ 0.025 - 0.010	+ 0.635 - 0.254						
08	0.803	20.40	0.668/0.686	16.99/ 17.42	-	-	0.250	6.40	-	-	0.395	10.0	1.375	34.93
10	0.858	21.79	0.736/0.750	18.69/ 19.05	-	-	0.312	7.90	-	-	0.457	11.60	1.437	36.50
12	0.984	24.99	0.860/0.875	21.84/ 22.23	0.312	7.90	0.438	11.10	0.457	11.60	0.583	14.80	1.562	39.67
14	1.157	29.39	0.980/1.000	24.89/ 25.40	0.438	11.10	0.562	14.30	0.583	14.80	0.707	18.00	1.687	42.85
16	1.280	32.51	1.100/1.125	27.89/28.58	0.500	12.70	0.625	15.90	0.645	16.40	0.770	19.60	1.750	44.45
18	1.406	35.71	1.224/1.250	31.09/31.75	0.625	15.90	0.750	19.10	0.770	19.60	0.895	22.70	1.875	47.63
20	1.516	38.51	1.348/1.375	34.24/34.93	0.625	15.90	0.812	20.60	0.770	19.60	0.957	24.30	1.938	49.23
22	1.642	41.51	1.469/1.500	37.31/38.10	0.688	17.50	0.938	23.80	0.829	21.10	1.083	27.50	2.062	52.37
24	1.768	44.91	1.581/1.625	40.16/41.28	0.750	19.10	1.000	25.40	0.895	22.70	1.145	29.10	2.125	53.98

TABLE-A (CON.)

SHELL SIZE	E MAX.		F MAX.		G MAX.		S (NO OF SLOTS)	
	INCH	MM	INCH	MM	INCH	MM	INCH	MM
08	1.417	35.90	1.01	25.07	1.16	29.50	0.170	4.31
10	1.480	37.59	1.03	26.20	1.19	30.20	0.170	4.31
12	1.553	39.45	1.06	26.90	1.21	30.70	0.170	4.31
14	1.614	41.00	1.08	27.40	1.24	31.50	0.250	6.35
16	1.678	42.62	1.11	28.20	1.26	32.00	0.250	6.35
18	1.773	45.03	1.12	28.40	1.27	32.30	0.500	12.70
20	1.796	45.62	1.15	29.20	1.30	33.00	0.500	12.70
22	1.859	47.22	1.17	29.70	1.33	33.80	0.500	12.70
24	1.919	48.74	1.20	30.50	1.35	34.30	0.500	12.70



EMI/RFI

Non-Environmental

Strain Relief Low Profile Backshell

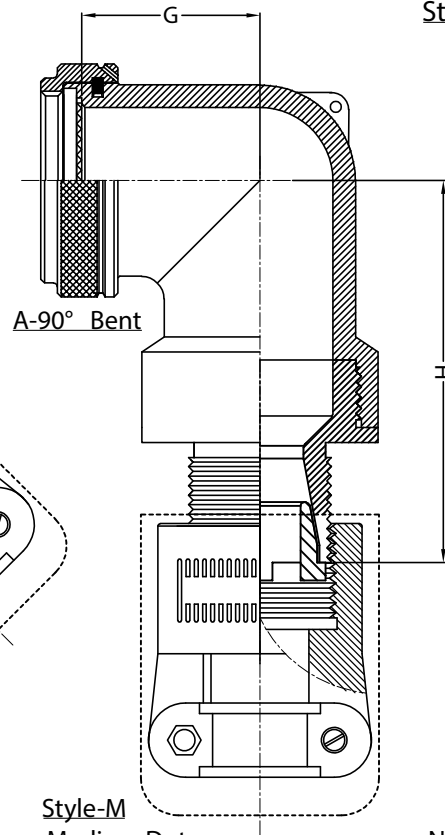
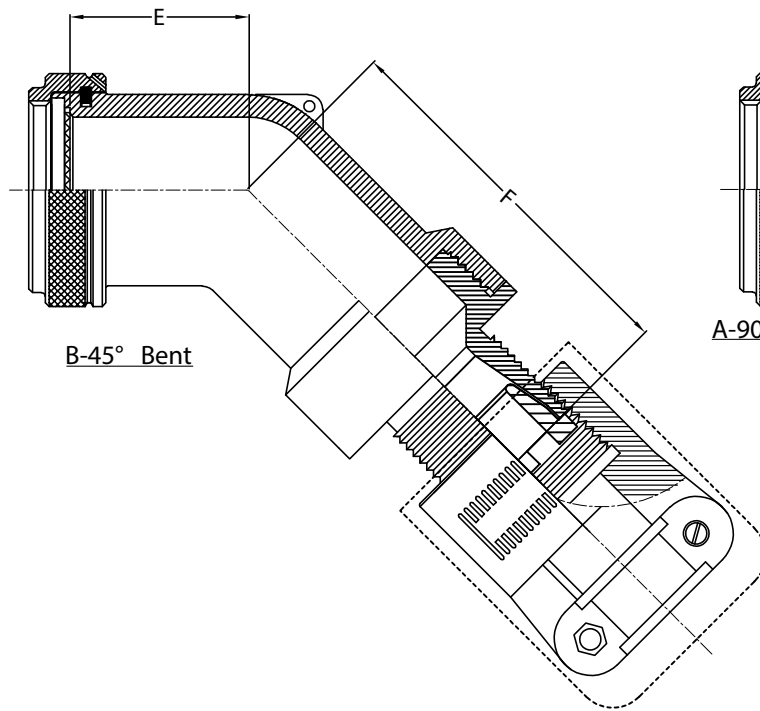
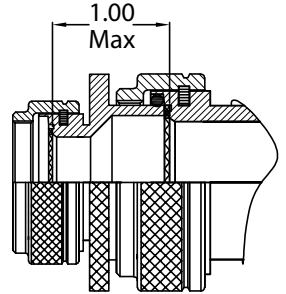
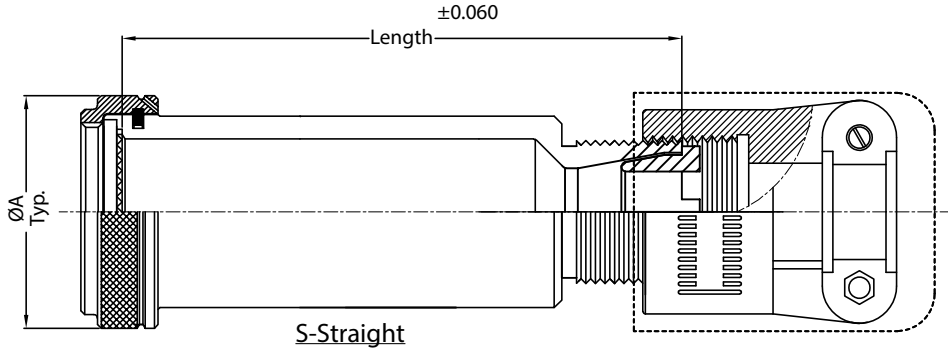

Style-H
 Clamp Heavy Duty
 (Table-2)

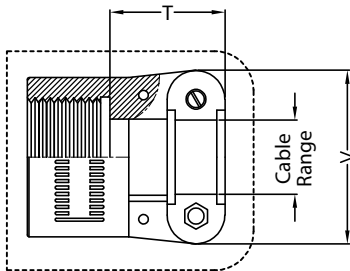

Style-S
 Clamp Medium Duty
 (Table-3)

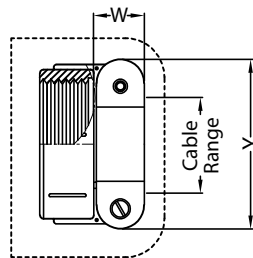

Style-M
 Clamp Medium Duty
 (Table-3)

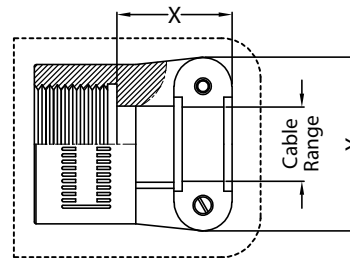

Style-N
 Nut Medium Duty
 (Table-3)

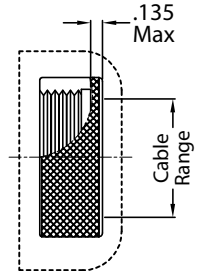

HOW-TO-ORDER

EMI/RFI Non-Environmental Strain Relief Low Profile Backshell

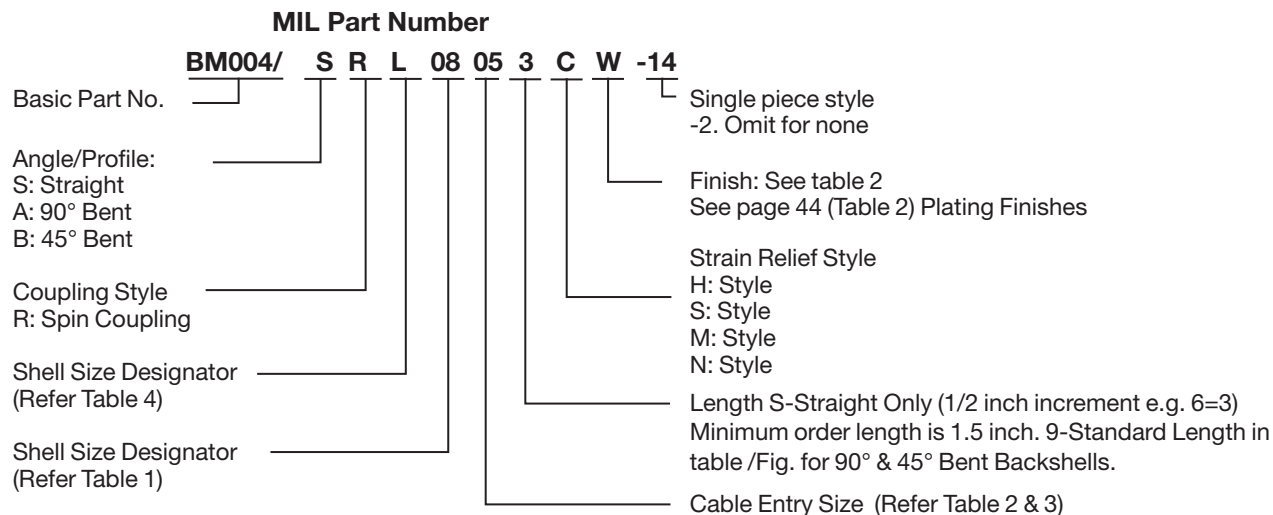

TABLE 1

SHELL SIZE DESIGNATOR	SHELL SIZE CONNECTOR		V-THREADS CONNECTOR DESIGN			ØA MAX. CONNECTOR DESIGN		E MAX.	F MAX.	G MAX.	H MAX.
			UNEF		METRIC 1X6H						
			J-K-Q	L	J	K.Q.N	L				
08	08	09/A	0.500-20	0.4375-24	M12X1.0	0.650	0.752	0.722	1.602	0.722	1.612
10	10	11/B	0.625-24	0.5625-24	M15X1.0	0.770	0.850	0.816	1.662	0.816	1.732
12	12	13/C	0.750-20	0.6875-24	M18X1.0	0.940	1.000	0.818	1.772	0.818	1.752
14	14	15/D	0.875-20	0.8125-20	M22X1.0	1.020	1.149	0.922	2.062	0.922	2.072

TABLE 2

CABLE ENTRY SIZE	T MAX.	V ±0.020	CABEL RANGE	
			MIN.	MAX.
04	0.780	0.937	0.125	0.312
06	0.780	1.125	0.250	0.437
08	0.780	1.312	0.312	0.562
10	0.780	1.312	0.350	0.625
12	0.811	1.531	0.500	0.750
16	0.905	1.750	0.625	0.937
20	1.092	2.093	0.875	1.250
24	1.124	2.343	1.000	1.375
28	1.399	2.750	1.250	1.625
32	1.399	3.000	1.437	1.875

TABLE 3

CABLE ENTRY SIZE	W MAX.	X MAX.	Y REF.	CABLE RANGE	
				MIN.	MAX.
03	0.437	0.760	0.843	0.156	0.250
04	0.437	0.760	0.937	0.188	0.312
06	0.500	0.760	1.125	0.281	0.438
08	0.563	0.760	1.312	0.344	0.562
10	0.563	0.760	1.312	0.375	0.625
12	0.563	0.760	1.531	0.438	0.750
16	0.656	1.073	1.750	0.562	0.938
20	0.656	1.323	2.093	0.750	1.250
24	0.656	1.323	2.343	0.781	1.375

TABLE 4

CONNECTOR CODE	CONNECTORS
K	SERIES FIVE

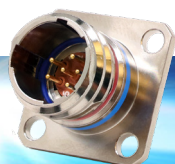

BOARD LAYOUT FOR PCB-TERMINATION

INSERT ARRANGEMENT #8-35

Connector Type:	Series Five	Number of Contacts	Contact Size
Insert Designation:	8-35	6	22D

Contact Locations

Front face of pin insert shown

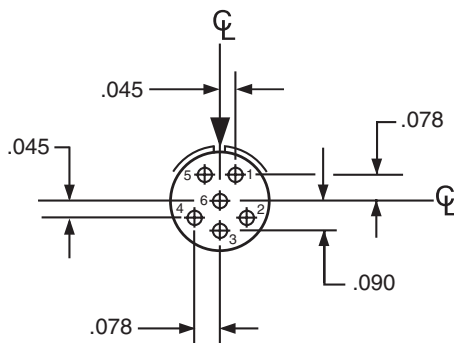

All dimensions for reference only. Note: Shown in this catalog are the most common insert patterns for PCB applications. For availability of other arrangements, consult Amphenol Aerospace.



BOARD LAYOUT FOR PCB-TERMINATION

INSERT ARRANGEMENT #8-98

Connector Type:	Series Five	Number of Contacts	Contact Size
Insert Designation:	8-98	3	20

Contact Locations

Front face of pin insert shown

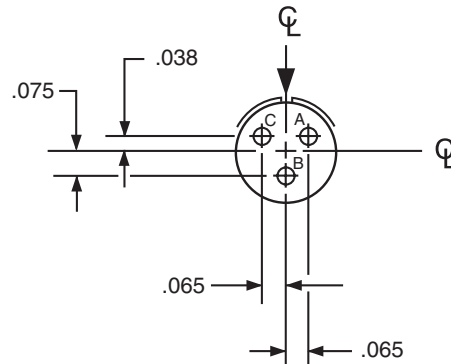

INSERT ARRANGEMENT #10-5

Connector Type:	Series Five	Number of Contacts	Contact Size
Insert Designation:	10-5	5	20

Contact Locations

Front face of pin insert shown

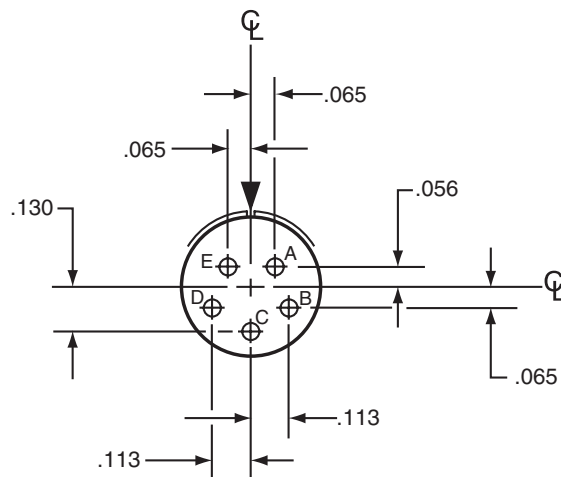

All dimensions for reference only. Note: Shown in this catalog are the most common insert patterns for PCB applications. For availability of other arrangements, consult Amphenol Aerospace.

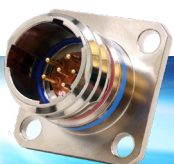

BOARD LAYOUT FOR PCB-TERMINATION

INSERT ARRANGEMENT #10-35

Connector Type:	Series Five	Number of Contacts	Contact Size
Insert Designation:	10-35	13	22D

Contact Locations

Front face of pin insert shown

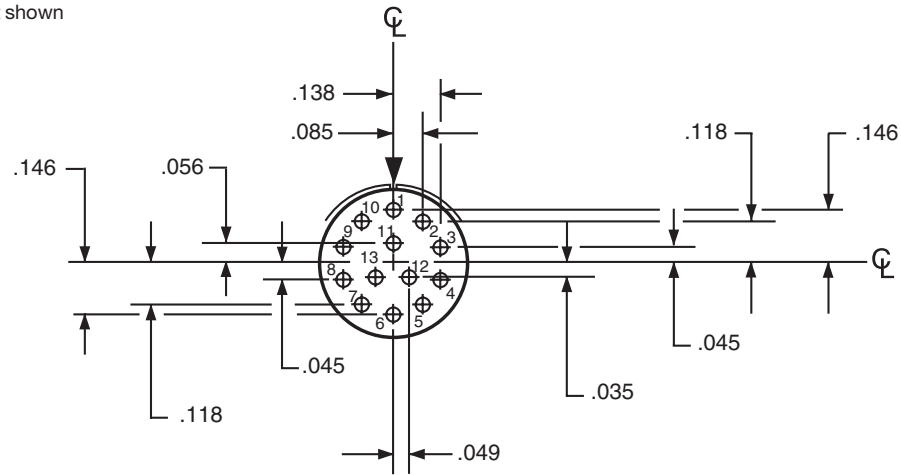

INSERT ARRANGEMENT #12-3

Connector Type:	Series Five	Number of Contacts	Contact Size
Insert Designation:	12-3	3	16

Contact Locations

Front face of pin insert shown

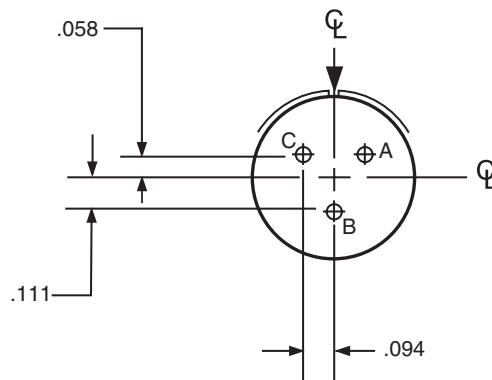

All dimensions for reference only. Note: Shown in this catalog are the most common insert patterns for PCB applications. For availability of other arrangements, consult Amphenol Aerospace.



BOARD LAYOUT FOR PCB-TERMINATION

INSERT ARRANGEMENT #12-35

Connector Type:	Series Five	Number of Contacts	Contact Size
Insert Designation:	12-35	22	22D

Contact Locations

Front face of pin insert shown

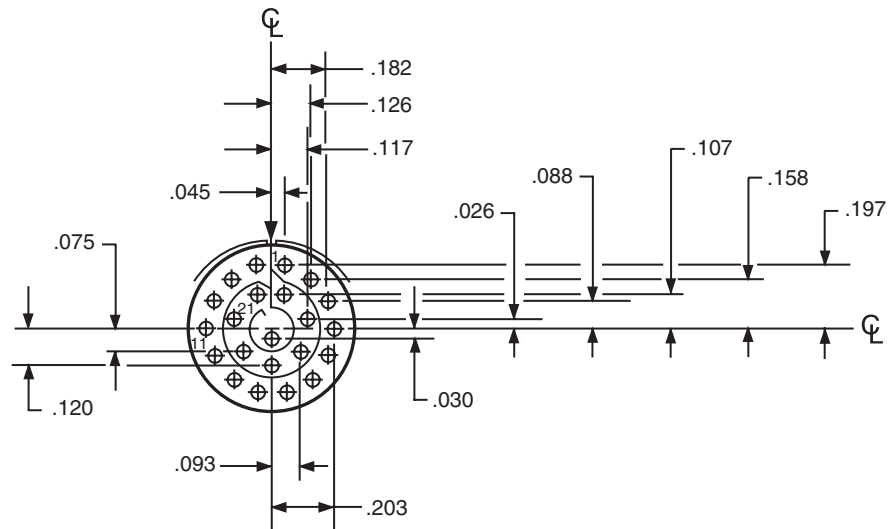

INSERT ARRANGEMENT #14-18

Connector Type:	Series Five	Number of Contacts	Contact Size
Insert Designation:	14-18	18	20

Contact Locations

Front face of pin insert shown

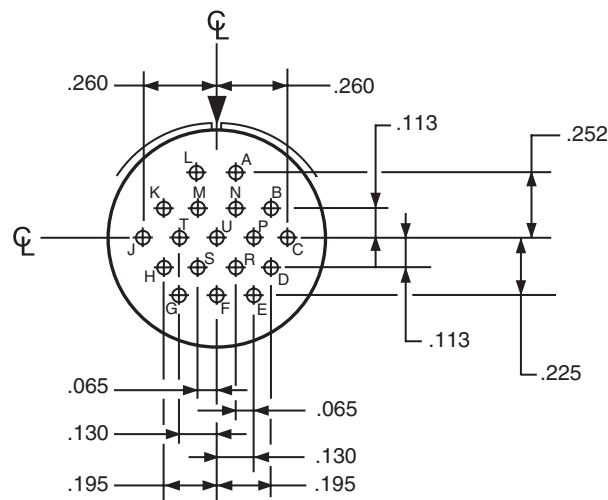

All dimensions for reference only. Note: Shown in this catalog are the most common insert patterns for PCB applications. For availability of other arrangements, consult Amphenol Aerospace.

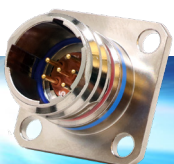

BOARD LAYOUT FOR PCB-TERMINATION

INSERT ARRANGEMENT #14-19

Connector Type:	Series Five	Number of Contacts	Contact Size
Insert Designation:	14-19	19	20

Contact Locations

Front face of pin insert shown

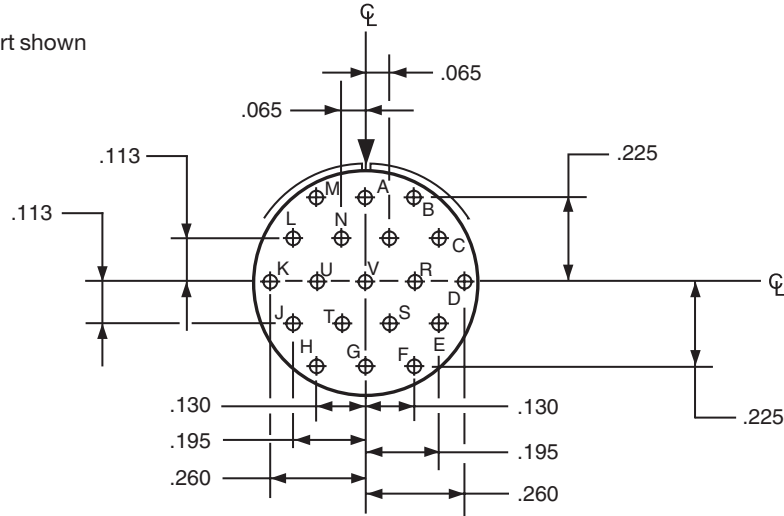

INSERT ARRANGEMENT #14-35

Connector Type:	Series Five	Number of Contacts	Contact Size
Insert Designation:	14-35	37	22D

Contact Locations

Front face of pin insert shown

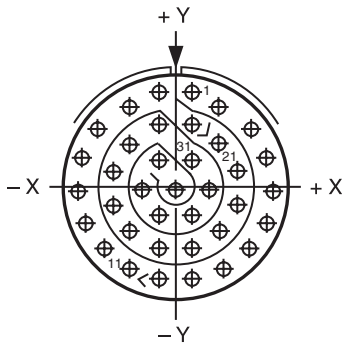

Contact Hole Locations			Contact Hole Locations		
Contact Number	Location		Contact Number	Location	
	X Axis	Y Axis		X Axis	Y Axis
1	+0.045	+0.262	19	+0.045	+0.172
2	+0.123	+0.217	20	+0.123	+0.119
3	+0.211	+0.160	21	+0.170	+0.040
4	+0.254	+0.080	22	+0.170	-0.050
5	+0.266	-0.010	23	+0.123	-0.127
6	+0.247	-0.098	24	+0.045	-0.172
7	+0.200	-0.175	25	-0.045	-0.172
8	+0.130	-0.232	26	-0.123	-0.127
9	+0.045	-0.262	27	-0.170	-0.050
10	-0.045	-0.262	28	-0.170	+0.040
11	-0.130	-0.232	29	-0.123	+0.119
12	-0.200	-0.175	30	-0.045	+0.172
13	-0.247	-0.098	31	+0.045	+0.074
14	-0.266	-0.010	32	+0.090	-0.004
15	-0.254	+0.080	33	+0.045	-0.082
16	-0.211	+0.160	34	-0.045	-0.082
17	-0.123	+0.217	35	-0.090	-0.004
18	-0.045	+0.262	36	-0.045	+0.074
			37	.000	-0.004

All dimensions for reference only. Note: Shown in this catalog are the most common insert patterns for PCB applications. For availability of other arrangements, consult Amphenol Aerospace.



AP-93 PLATING - 1000 HOURS ALTERNATIVE TO CADMIUM

RoHS Compliant Tri-Nickel Alloy, Intermateable with Cadmium



Amphenol Aerospace introduces **AP-93** -- a new, durable REACH/RoHS compliant plating for aluminum connectors which outperforms Cadmium and exceeds 1000 hour salt spray requirements. **AP-93** is a conductive finish that meets or exceeds D38999 Cadmium requirements (under the commercial service class designator "DS") making it an excellent choice for harsh environments.

Military, commercial, and industrial markets continue to move away from Cadmium due to known toxic carcinogens. The new **AP-93** plating finish complies with all customer requirements tied to these specifications. Amphenol is also using European Union Directive 2002/95/EC RoHS as a guide to qualification for all military, commercial, and industrial specifications requiring the reduction or elimination of these restricted materials.

AP-93 is intermateable with Cadmium, making it a drop-in replacement for applications where Cadmium has been a preferred choice. Applications include numerous components of land, sea, air, and weapons systems, as well as space systems, as it provides superior barrier protection and excellent lubricity for threaded applications.

AP-93 exceeds Olive-Drab Cadmium plating (Class W) by meeting 1000 hours of dynamic salt spray, 500 mating cycles, and meets the millivolt drop shell-to-shell conductivity of nickel (Class F). **AP-93** also meets a 200° C temperature rating, is compatible with other platings, and is available on all D38999-style connectors. For specific applications please contact Amphenol Aerospace.

FEATURES & BENEFITS

- Available on all Series Five style connectors
- Meets 1000 hour salt spray requirement
- Meets D38999 Class "F" shell-to-shell requirements
- REACH/RoHS compliant
- Intermateable with Cadmium -- excellent drop-in replacement for existing connectors.
- 500 mating cycles per D38999
- Meets 200° C temperature rating
- Passes 336 hours of SO2 Exposure
- Conforms to MIL-DTL-38999 service class "AA"

Requirements	Nickel	CAD	AP-93
336 Hours SO2 Exposure			*
500 Hours Salt Spray		*	*
1000 Hours Salt Spray			*
Meets 336 hours of SO2 Resistance			*
REACH/RoHS Compliant	*		*
CAD Intermateable		*	*
Non-Magnetic	*	*	*
Temperature Rating 200° C	*		*
Shell-to-Shell Conductivity < 2.5 millivolt	*	*	*

Note: Specifications are subject to change without notice.

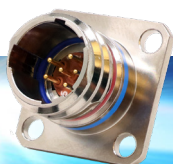

ABOUT AMPHENOL AEROSPACE

Your Source for Interconnect Products



CONTACT US:

Amphenol Aerospace
40-60 Delaware Avenue
Sidney, NY 13838-1395

Customer Service:

Mon - Fri 8AM - 5PM
Phone: (800) 678-0141

Fax: (607) 563-5157

Online: www.amphenol-aerospace.com



*Amphenol Aerospace, Amphenol Commercial Air,
and Amphenol Industrial Operations Main Facility in Sidney, NY USA*

ABOUT AMPHENOL AEROSPACE:

Amphenol Aerospace, a Division of Amphenol Corporation, is one of the largest manufacturers of interconnect products in the world for the Military, Commercial Aerospace and Industrial markets. Amphenol designs, manufactures and markets circular and rectangular, electronic, fiber optic, EMI/EMP filter, and a variety of special applications connectors and interconnect systems.

Our state-of-the-art facility is nestled at the foothills of the Catskill Mountains in Sidney, NY. The Amphenol complex houses many technologies including CNC machining, die-casting, molding, impact and extruding, plating, screw machining and process controls. Our fully equipped material evaluation lab and engineering organization utilize the latest in computer aided design software and analysis tools, allowing us to design, test, and qualify advanced interconnect systems. Amphenol's interconnect products are supplied to thousands of OEMs worldwide and are supported by our worldwide sales and engineering force, including the largest global network of electronic distributors.



Customer-Centric:

Our #1 priority is our customers who deserve quality product on time.

Accountable:

Clear owners, clear actions, clear results.

Reliable:

What we build matters and quality is imperative.

Enthusiastic:

Challenges create rewarding opportunities. Enthusiasm is contagious and we will spread it.

QUALITY ASSURANCE:

Amphenol Aerospace has been awarded both AS9100 - Revision C and ISO9001:2008 Quality Assurance Certifications.



Amphenol

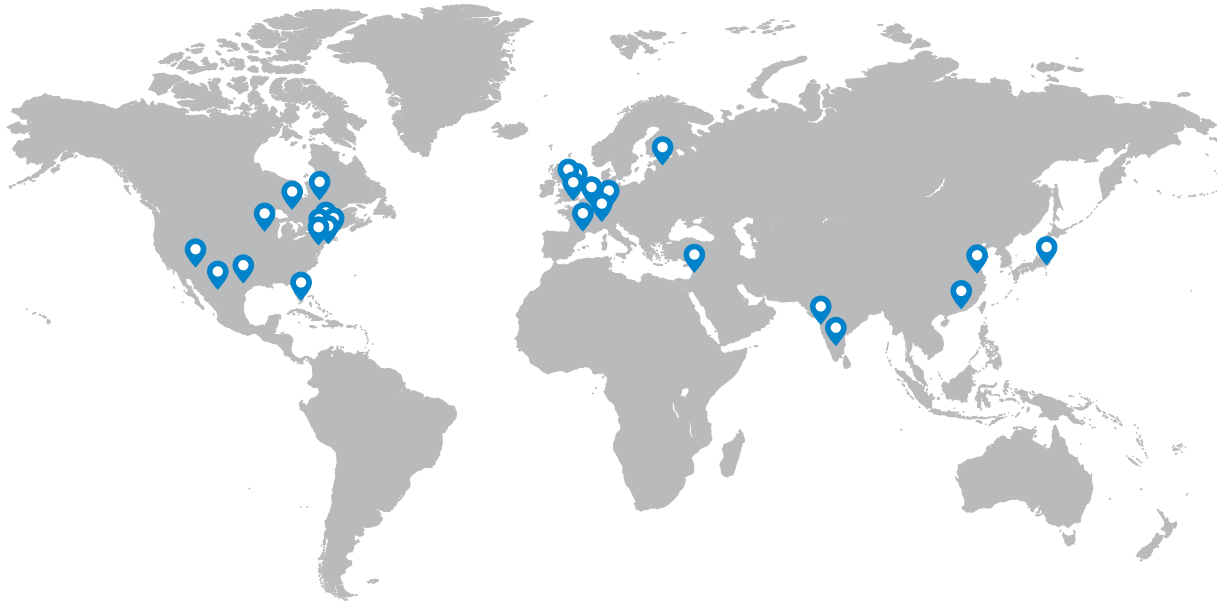

Amphenol Aerospace Operations

40-60 Delaware Avenue
Sidney, NY 13838
800-678-0141

Amphenol Commercial Air Division

40-60 Delaware Avenue
Sidney, NY 13838
1-800-687-0141

Amphenol Nexus Technologies

316 Courtland Avenue
Stamford, CT 06906
203-327-7300

Amphenol PCD

72 Cherry Hill Drive
Beverly, MA 01915
978-624-3400

Amphenol SV Microwave

2400 Centrepark West Drive
West Palm Beach, FL
561-840-1800

Amphenol Times Microwave, Inc.

358 Hall Avenue
Wallingford, CT 06492
800-867-2629

Amphenol Fiber Systems International

1300 Central Expressway North, Suite 100
Allen, TX 75013
214-547-2400

Amphenol Borisch Technologies

4511 East Paris AVE
Grand Rapids, MI 49512
616-554-9820

Amphenol Printed Circuits

91 Northeastern Boulevard
Nashua, NH 03062
603-324-4500

Amphenol Canada

5950 14th Ave
Markham, ON L3S 3K5
416-291-4401

Amphenol Invotec

Unit 1-3, Hedging Lane Industrial Estate
Dosthill, Tamworth, B77 5HH United Kingdom
+44 (0) 1827 263250

Amphenol Ionix Systems

Prospect House, Taylor Business Park
Risley, Warrington, WA3 6HP United Kingdom
+44 (0) 1942 685200

Amphenol Limited

Thanet Way
Whitstable, Kent, CT5 3JF United Kingdom
+44 (0) 1227 773200

Amphenol Socapex

948 Promenade De L'Arve – BP 29
74311 Thyez France
+33 (0) 4 50 89 28 00

Amphenol Air LB SAS

2 Rue Clément Ader, Zac de Wé
08110 Carignan France
+33 (0) 03 24 22 78 49

Amphenol AirLB GmbH

Am Kleinbahnhof 4
D-66740 Saarlouis Germany
+49 (0) 68 31/98 10 0

Amphenol SEFEE

Z.I. des Cazes – BP243
12402 Saint-Affrique Cedex France
+33 (0) 5 65 98 11 00

Amphenol Interconnect India

105, Bhosari Industrial Area
Pune – 411 026 India
+91 20 27120363

Amphenol Japan, Ltd.

471-1, Deba, Ritto-City
Shiga, 520 3041 Japan
+81 77 553 8501

Amphenol Martec Limited

St. Augustines Business Park
Swalecliffe, Whitstable, Kent
CT5 2QJ United Kingdom
+44 (0) 1227 793 733

Amphenol Optimize

Carretera Internacional Km 6.5
Col. Parque Industrial
Nogales, Sonora, México. C.P. 84094
+52 (631) 311-160

Amphenol Ionix Systems OÜ

Pikk Street 59b
Kuressaare 93815 Estonia
+372 4521 780

AMAQ – European Sales Operations

Via Barbaiana 5
20020 Lainate Milano, Italy
+39 02 932 541

Amphenol Bar-Tec Ltd.

3 Hagavish st
POB 2479 Kfar-Saba 44641
Israel
+972-9-7644100



AMPHENOL CORPORATION
40-60 Delaware Avenue, Sidney, NY 13838-1395 • 800-678-0141
www.amphenol-aerospace.com • www.amphenolmao.com