

21-33591-1

Contact, Socket, Coaxial, Type LJT-R, TV-R (MIL-DTL-38999 Series I & III)
Installation Instructions

See table on reverse side for coaxial cable recommended, stripping dimensions, tool selector settings, crimping tool and positioner information.

- A**
- The contact incorporates a piggyback grommet seal. Assemble the grommet seal over the cable jacket before stripping cable.
 - Strip cable as illustrated. Ends must be cut cleanly and at right angles to the axial plane of the cable. The cable must not be deformed while making cuts. Hot wire stripping is recommended.
- B**
- Slide shield crimp sleeve over cable jacket.
 - Trim shield to .300 dimension.
 - Strip cable core (inside insulation) to .150 dimension, exposing cable center conductor.
- C**
- Position nut on retainer as illustrated.
 - Flare shield and slide nut and retainer assembly under the cable shield until retainer bottoms against braid. (Approximately .070 of the cable core should be exposed).
- FOR CRIMP TERMINATION OF CENTER CONTACT**
- D**
- Slide inner pin contact over cable center conductor. Cable center conductor must be visible through the inspection hole in the inner pin contact wire well.
 - Crimp inner pin contact using crimp tool and positioner listed in table on back.
- E**
- Slide nut and retainer assembly forward until retainer is flush with edge of cable core.
 - Bring shield crimp sleeve forward over cable shield and observe .010 to .030 inch dimension.
 - Crimp shield crimp sleeve using tool and dies listed in table on back. Nut must rotate freely after crimping shield crimp sleeve.
- F**
- Slide rear insulator on Expander Tool Amphenol P/N 11-10136, or locally fabricated equivalent.
 - Slide tool over inner pin contact. Push rear insulator with push rod Amphenol P/N 11-10135, or locally fabricated equivalent, until it seats between retainer end and inner pin contact shoulder.
 - Remove push rod expander and proceed to step H.
- FOR SOLDER TERMINATION OF CENTER CONTACT**
- G**
- Crimp shield crimp sleeve per steps E1, E2 and E3.
 - Install rear insulator on back of inner pin contact. Trim fit contact and insulator assembly to center conductor. Trim center conductor to allow rear insulator to butt against the retainer when inner pin contact is installed.
 - Tin center conductor, and using a 47.5 watt soldering iron, solder the center conductor into the inner pin contact wire well. A pin vise can be used to hold the inner contact.
- H**
- Slide front insulator, large end first, over the inner pin contact until insulator seats against the inner pin contact shoulder.
- J**
- Slide outer socket contact over inner pin assembly and insulator, and thread nut into rear of outer socket contact.
 - Tighten nut until metal to metal bottoming is achieved between retainer shoulder and outer socket contact. Torque on nut shall be 30-36 inch ounces. DO NOT allow the cable to rotate while tightening the nut.

21-33591-1

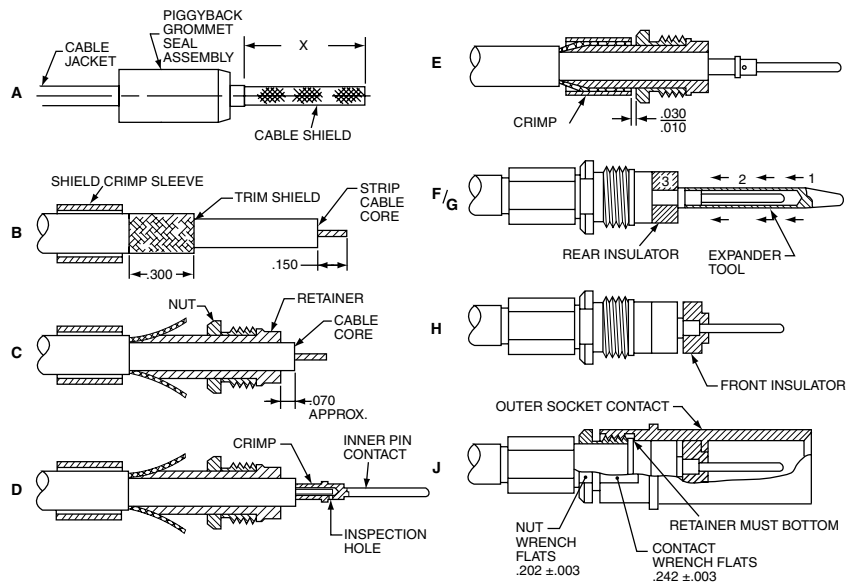

Amphenol Aerospace

AMPHENOL CORPORATION
Amphenol Aerospace
40-60 Delaware Avenue
Sidney, New York 13838-1395
www.amphenol-aerospace.com

L-1107-AP
October 2013

FSCM77820

PART NO.	COAXIAL CABLE ACCOMODATED	X STRIPPING DIMENSION (INCH)	TOOLS					
			INNER CONTACT			SHIELDED SLEEVE		
			TOOL SELECTOR SETTING NO.	BASIC CRIMPING TOOL	POSITIONER	BASIC CRIMPING TOOL	DIE	DIE CLOSURE
21-33591-1	M17/094-RG179	.750	3	M22520/2-01	M22520/2-31	M22520/5-01	M22520/5-08	A
						M22520/10-01	M22520/10-05	A
				Solder Termination Optional				

EXPANDER TOOL

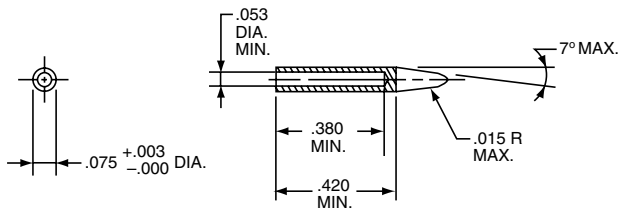

PUSH ROD

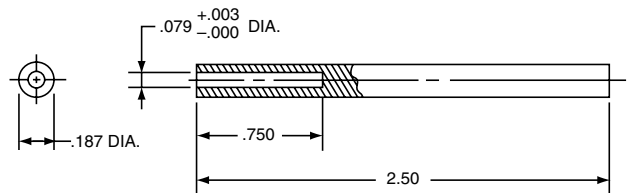

CONTACT INSERTION INTO CONNECTOR
Contacts are inserted by hand. Slide the wire sealing member on the cable and over the crimped shield crimp sleeve. Insert the contact/cable assembly into proper rear grommet hole. Contact must be aligned with hole and not inserted at an angle. Push forward until contact and wire sealing member is felt to snap into position within the insert. Gently tug on the cable to assure retention.

CONTACT REMOVAL FROM THE CONNECTOR
Remove wire sealing member from grommet. Position Amphenol removal tool part number 11-9170 or Daniels DRK-264-8 around cable and slide tool toward connector until tool tips enter rear grommet and come to a positive stop on contact. Grip cable and simultaneously remove tool, contact and cable.