

21-33102-22

Contact, Pin, Coaxial Type LJT-RE, TV-R Crimp (MIL-C-38999 Series I & III)  
Installation Instructions

See table on reverse side for coaxial cable recommended, stripping dimensions, tool selector settings, crimping tool and positioner information.

- A** 1. The connector incorporates a piggyback grommet seal. This member must be slid onto the cable prior to assembly of the coaxial contact to the coaxial cable. Be sure the metal sleeve has been installed inside the sealing member.
2. Strip cable as illustrated. Ends must be cut cleanly and at right angles to the axial plane of the cable. The cable must not be deformed while making cuts. Hot wire stripping is recommended.
- B** 1. Slide shield crimp sleeve over cable shield until flush with edge of cable jacket.
2. Trim shield flush with edge of shield crimp sleeve.
- C** 1. Slide shield crimp sleeve back over cable jacket.
2. Position nut on retainer as illustrated.
3. Flare shield and slide nut and retainer assembly under the cable shield until retainer bottoms against shield.
4. Strip cable core (inside insulation) flush with end of retainer, exposing cable center conductor.
- FOR CRIMP TERMINATION OF CENTER CONTACT**
- D** 1. Remove nut and retainer assembly from cable end.
2. Slide inner socket contact over cable center conductor. Cable center conductor must be visible through the inspection hole in the inner socket contact wire well.
3. Crimp inner socket contact using crimp tool and positioner listed in table on back.
- E** 1. Slide nut and retainer assembly over inner socket contact, cable core and under cable shield. Retainer must bottom against cable shield.
2. Bring shield crimp sleeve forward over cable shield and observe .010 to .050 inch dimension.
3. Crimp shield crimp sleeve using tool and dies listed in table on back. Nut must rotate freely after crimping shield crimp sleeve.
- F** 1. Slide rear insulator on Expander Tool Amphenol P/N 11-10136, or locally fabricated equivalent.
2. Slide tool over inner socket contact. Push rear insulator with push rod Amphenol P/N 11-10135, or locally fabricated equivalent, until it seats between retainer end and inner socket contact shoulder.
3. Remove push rod expander and proceed to step H.
- FOR SOLDER TERMINATION OF CENTER CONTACT**
- G** 1. Crimp shield crimp sleeve per steps E2 and E3.
2. Install rear insulator on back of inner socket contact. Fit contact and insulator assembly to center conductor. Trim center conductor to allow rear insulator to butt against the retainer when inner socket contact is installed.
3. Tin center conductor, and using a 47.5 watt soldering iron, solder the center conductor into the inner socket contact wire well. A pin vise can be used to hold the inner contact.
- H** 1. Slide front insulator, large end first, over the inner socket contact until insulator seats against the inner socket contact shoulder.
- J** 1. Slide outer pin contact over inner socket assembly and insulator, and thread nut into rear of outer pin contact.
2. Tighten nut until metal to metal bottoming is achieved between retainer shoulder and outer pin contact. Torque on nut shall be 30-36 inch ounces. DO NOT allow the cable or shield crimp sleeve to rotate while tightening the nut.

21-33102-22

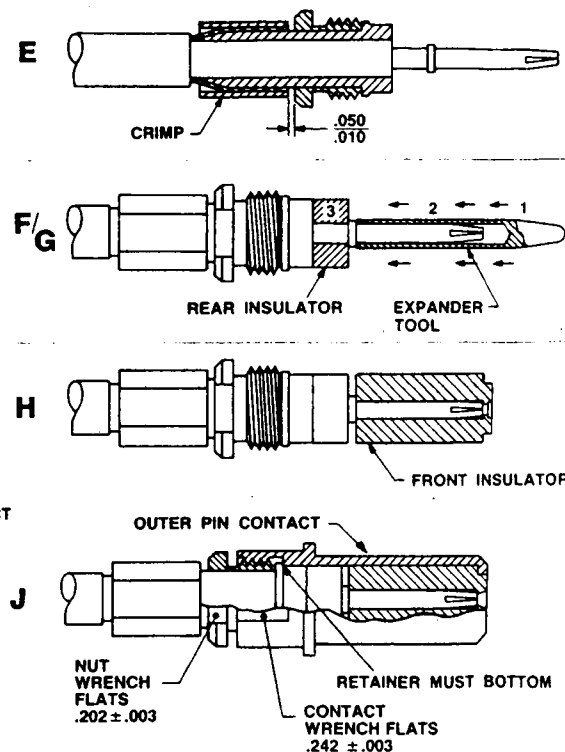
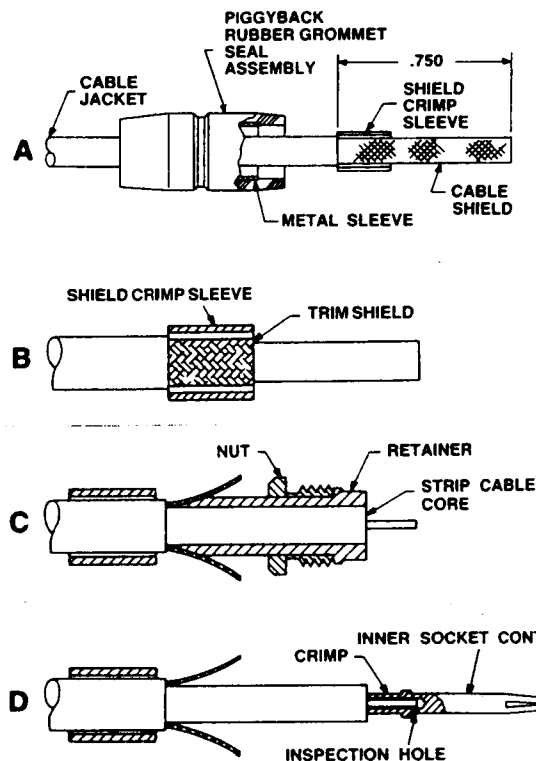

Amphenol Aerospace

PART NO.	COAXIAL CABLE ACCOMODATED	TOOLS						CONTACT REMOVAL TOOL/PIN
		INNER CONTACT*			SHIELD CRIMP SLEEVE			
		TOOL SELECTOR SETTING NO.	BASIC CRIMPING TOOL	POSITIONER	BASIC CRIMPING TOOL	DIE	DIE CLOSURE	
21-33101-22	McDonnell 5M1010	1	M22520/2-01	M22520/2-31	M22520/5-01 M22520/10-01	M22520/5-05 M22520/10-07	B B	MIL-I-81969/14-06 or Daniels DRK-264-8 or Amphenol 11-9170

\*May be soldered: See Para G of instructions.

#### EXPANDER TOOL

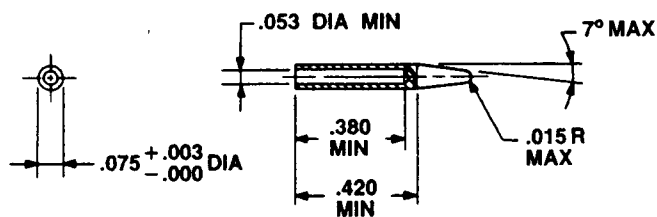

#### PUSH ROD

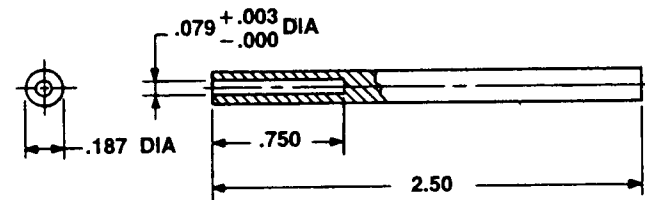

#### CONTACT INSERTION INTO CONNECTOR

Contacts are inserted by hand. Slide the wire sealing member on the cable and over the crimped shield crimp sleeve. Insert the contact/cable assembly into proper rear connector grommet hole. Contact must be aligned with hole and not inserted at an angle. Push forward until contact and wire sealing member is felt to snap into position within the insert. Gently tug on the cable to assure retention.

#### CONTACT REMOVAL FROM THE CONNECTOR

Remove wire sealing member from grommet. Position removal tool part number (listed in table above) around cable and slide tool toward connector until tool tips enter rear grommet and come to a positive stop. Hold tool tip firmly against positive stop on contact, grip cable and simultaneously remove tool, contact and cable.