

21-33101-25

Contact, Socket, Coaxial Type LJT-R, TV-R Crimp (MIL-DTL-38999 Series I & III)
Installation Instructions

See table on reverse side for coaxial cable recommended, stripping dimensions, stripping tool selector settings, crimping tool and positioner information.

- A**
1. The contact incorporates a piggyback grommet seal. Assemble the piggyback grommet seal over the cable jacket, rubber end first, before stripping cable.
 2. Strip cable as illustrated. Ends must be cut cleanly and at right angles to the axial plane of the cable. The cable must not be deformed while making cuts.
- B**
1. Slide shield crimp sleeve over cable shield until flush with edge of cable jacket.
- C**
1. Slide shield crimp sleeve back over cable jacket.
 2. Trim shields flush with edge of shield crimp sleeve.
 3. Flare shield and slide nut and retainer assembly under the cable shields until retainer bottoms against shields.
 4. Strip cable core (inside insulation) flush with end of retainer, exposing cable center conductor.
- FOR CRIMP TERMINATION OF CENTER CONTACT**
- D**
1. Remove nut and retainer assembly from cable end.
 2. Slide inner pin contact over cable center conductor. Cable center conductor must be visible through the inspection hole in the inner pin contact wire well.
 3. Crimp inner pin contact using crimp tool and positioner listed in table on back.
- E**
1. Slide nut and retainer assembly over inner pin contact, cable core and under cable shields. Retainer must bottom against shields.
 2. Bring shield crimp sleeve forward over cable shields and observe .010 to .050 inch dimension.
 3. Crimp shield crimp sleeve using tool and die listed in table on back. Nut must rotate freely after crimping shield crimp sleeve.
- F**
1. Slide rear insulator on Expander Tool Amphenol P/N 11-10136, or locally fabricated equivalent.
 2. Slide tool over inner pin contact. Push rear insulator with push rod Amphenol P/N 11-10135, or locally fabricated equivalent, until it seats between retainer end and inner pin contact shoulder.
 3. Remove push rod expander and proceed to step H.
- FOR SOLDER TERMINATION OF CENTER CONTACT**
- G**
1. Crimp shield crimp sleeve per steps E2 and E3.
 2. Install rear insulator on back of inner pin contact. Trim fit contact and insulator assembly to center conductor. Trim center conductor to allow rear insulator to butt against the retainer when inner pin contact is installed.
 3. Tin center conductor, and using a 47.5 watt soldering iron, solder the center conductor into the inner pin contact wire well. A pin vise can be used to hold the inner contact.
- H**
1. Slide front insulator, large end first, over the inner pin contact until insulator seats against the inner pin contact shoulder.
- J**
1. Slide outer socket contact over inner pin assembly and insulator, and thread nut into rear of outer socket contact.
 2. Tighten nut until metal to metal bottoming is achieved between retainer shoulder and outer socket contact. Torque on nut shall be 30–36 inch ounces. DO NOT allow the cable to rotate while tightening the nut.

21-33101-25

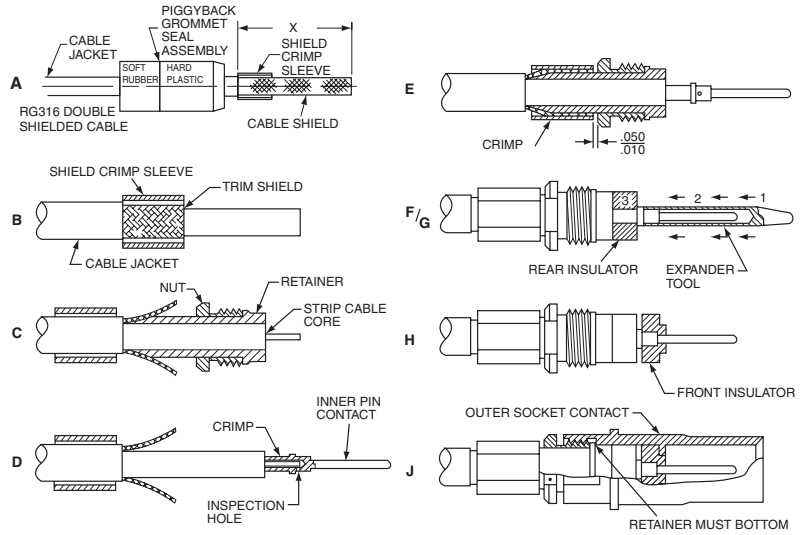

Amphenol

AMPHENOL CORPORATION
Amphenol Aerospace
40-60 Delaware Avenue
Sidney, New York 13838-1395
www.amphenol-aerospace.com

PART NO.	COAXIAL CABLE ACCOMODATED	X STRIPPING DIMENSION (INCH)	TOOLS					
			INNER CONTACT			SHIELDED SLEEVE		
			TOOL SELECTOR SETTING NO.	BASIC CRIMPING TOOL	POSITIONER	BASIC CRIMPING TOOL	DIE	DIE CLOSURE
21-33101-25	RG316 Double Shielded	.750	5	M22520/2-01	M22520/2-31	M22520/5-01 M22520/10-01	M22520/5-37 M22520/10-15	B A
Solder Termination Optional								

EXPANDER TOOL

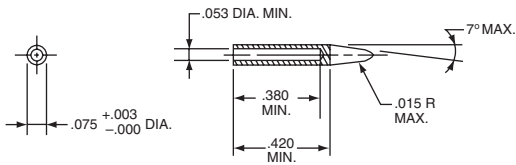

PUSH ROD

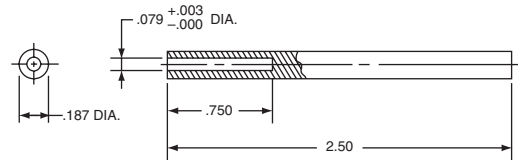

CONTACT INSERTION INTO CONNECTOR

Contacts are inserted by hand. Slide the wire sealing member (piggyback grommet seal) on the cable and over the crimped shield crimp sleeve. Insert the contact/cable assembly into proper rear grommet hole. Contact must be aligned with hole and not inserted at an angle. Push forward until contact and wire sealing member is felt to snap into position within the insert. Gently tug on the cable to assure retention.

CONTACT REMOVAL FROM THE CONNECTOR

Remove wire sealing member from grommet, (piggyback grommet seal). Position Amphenol removal tool part number 11-9170 or Daniels DRK-264-8 around cable and slide tool toward connector until tool tips enter rear grommet and come to a positive stop on contact. Grip cable and simultaneously remove tool, contact and cable.