

21-033190-631 (PIN)

21-033191-631 (SOCKET)

Contact, Pin & Socket, Concentric Twinaxial Type,
(MIL-DTL-38999 Series I & III)

Installation Instructions

1. Assemble Seal: See Figure 1.
2. Strip cable per Figure 2.
3. Assemble crimp bushing over cable jacket, until cable jacket butts inside shoulder of busing. Flair outer shield as shown. (Cut off fillers as close to outer shield as possible). Strip inner wires as shown. Trim excess shield.
4. Bend white wire away from blue wire and assemble inner contact assembly over blue wire and butt firmly against crimp bushing as shown. Align insulator slot with white wire. Crimp inner contact to blue wire conductor.
5. Slide rear intermediate contact over inner contact assembly as shown, being sure all strands of the white conductor enter small hole in the intermediate contact large end. Slot in intermediate contact should be 180 degrees opposite white wire. Crimp rear intermediate contact wire well using tool (Die set has a blade for location of slot and a double indent portion to crimp wire side).
6. Slide outer contact assembly over inner contact assembly until it butts firmly. A small gap at the bushing will occur. Crimp assembly, bushing and outer contact.

Contact insertion into connector:

Contact are inserted by hand

Insert the contact assembly into the connector cavity until it seats firmly. Tug slightly on wire to insure contact has properly seated. Slide Piggyback grommet down cable until it butts firmly on contact.

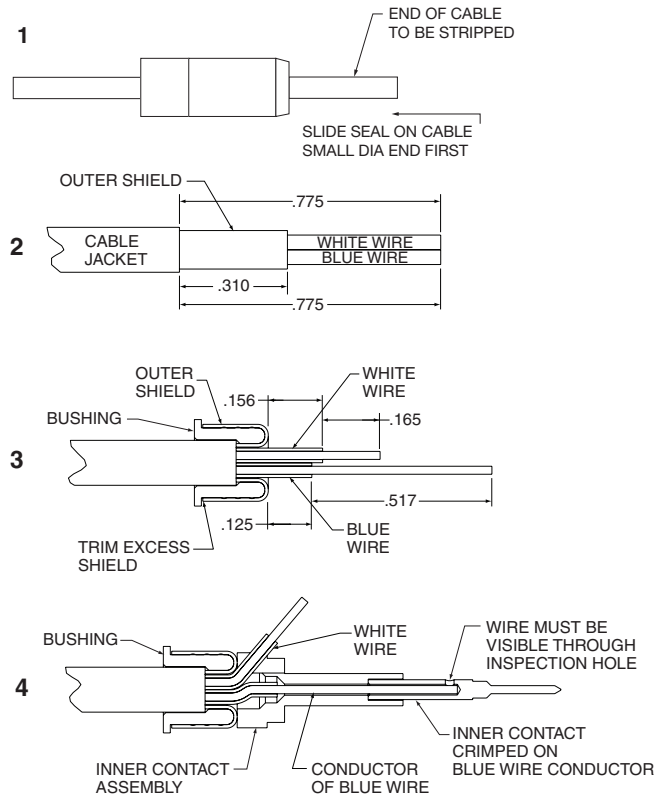

Amphenol

L-1253-AJ
June 2022

FSCM77820

Amphenol Aerospace • 40-60 Delaware Avenue • Sidney, New York 13838-1395
Website: www.amphenol-aerospace.com

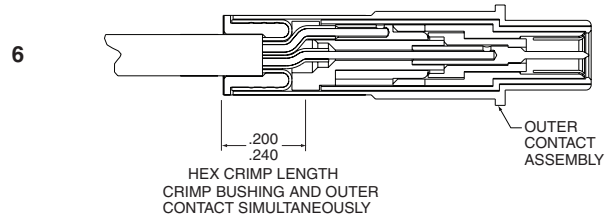
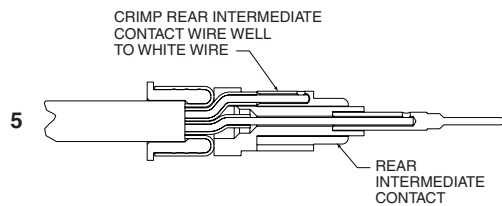

Amphenol Part Number	Description	Twinax Cable Recommended	Tools					
			Inner Contact		Intermediate Contact		Outer Contact	
			Tool (Setting)	Positioner	Tool	Die Set (Location)	Tool	Die Set (Location)
21-033190-631	Concentric Twinax (Pin)	M17/176-00002	M22520/2-01 (5)	Daniels K709 (M22520/2-37)	M22520/5-01	M22520/5-105	M22520/5-01	M22520/5-105
21-033191-631	Concentric Twinax (Socket)							

Amphenol

Amphenol Aerospace
40-60 Delaware Avenue
Sidney, New York 13838-1395
Website: www.amphenol-aerospace.com