

21-33191-530

21-33191

21-33191-1

M39029/91-530

Contact, Socket, Concentric Twinaxial Type, Shielded, Crimp (MIL-C-38999 Series I & III)  
Installation Instructions

**Note:** 21-33191-530 contact with Type I Seal is designed for use in MIL-C-38999 Series III special connector arrangement 25-20 for MIL-STD-1760 applications only.

**Note:** 21-33191 and 21-33191-1 contacts with Type II Seal are designed for use in MIL-C-38999 Series I and III standard connector arrangements 25-46, 21-75, and 21-79 only.

For 21-33191: Type II Seal provided with connector.

For 21-33191-1: Type II Seal provided with contact.

1. Assemble Seal. See Figure 1.  
Type I: Preformed heat shrinkable contact/wire seal.  
Type II: Piggyback grommet seal.
2. Strip cable per Fig. 2.
3. Screw crimp bushing over cable jacket, flair shield and strip inner wires as shown. (Cut off fillers as close to shield as possible).
4. Assemble spacer insulator over blue and white wires.
5. Bend white wire away from blue wire and assemble back insulator over blue wire and butt firmly against spacer insulator. Align slot with white wire.
6. Fit inner socket contact over blue wire conductor (See Fig. 6) and crimp with M22520/2-01 tool and M22520/2-37 positioner. Use tool selector setting number five (5).
7. Assemble inner front insulator over center socket contact being careful to align slot with white wire as insulator is slid back until it butts firmly.
8. Slide intermediate contact over inner front insulator being sure all strands of the white conductor enter small hole in the intermediate contact large end. Slot in intermediate contact should be 180 degrees opposite white wire.
9. Crimp intermediate contact wire well using tool M22520/5-01 and die set M22520/5-200 (Die set has a blade for location of slot and a double indent portion to crimp wire side).
10. Slide large front insulator over intermediate contact assembly until it butts firmly.
11. Slide outer socket contact over insulators until inside components firmly butt. A small gap at bushing will occur.
12. Crimp assembly, bushing and outer contact, with tool M22520/5-01 and die set M22520/5-200.
13. Type I Seal  
Slide preformed heat shrink seal over outer contact until large end is even with base of chamfer on outer contact (See Fig. 13). Heat shrink seal in place with hot air appliance.  
Type II Seal: Go to step 14
14. Insert the contact assembly into the connector grommet until it seats firmly. Tug slightly on wire to insure contact has properly seated.
15. Type II Seal:  
Slide Piggyback Grommet down cable until it butts firmly on contact.

L-1253-B  
July 1989

FSCM 77820

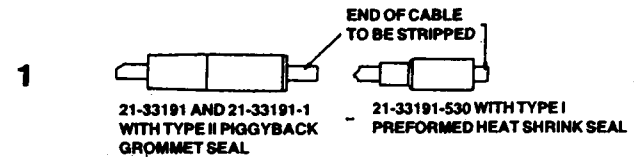

SLIDE SEAL ON CABLE  
SMALL DIA END FIRST

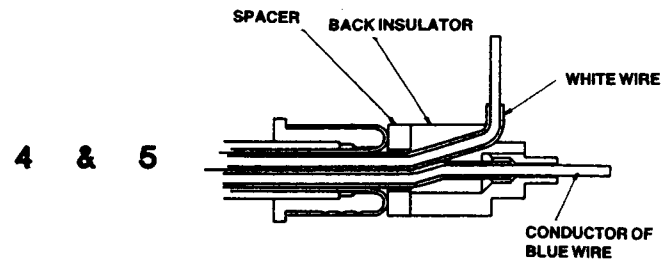
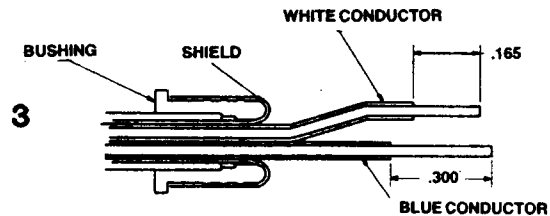
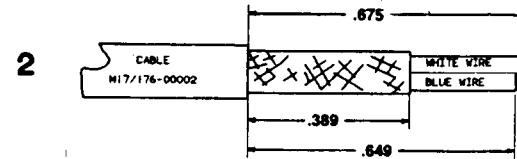

Amphenol

an LPL company

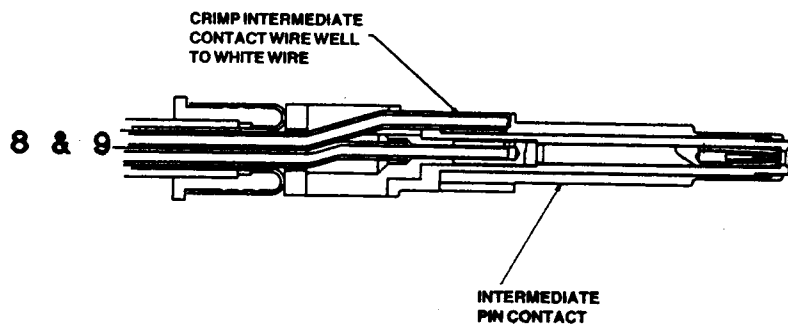
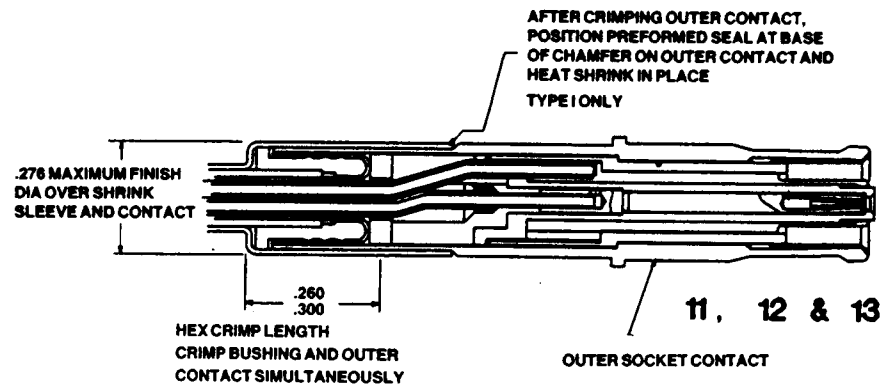
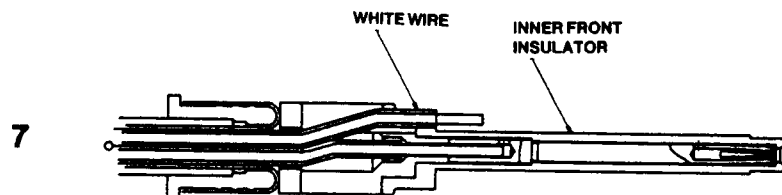
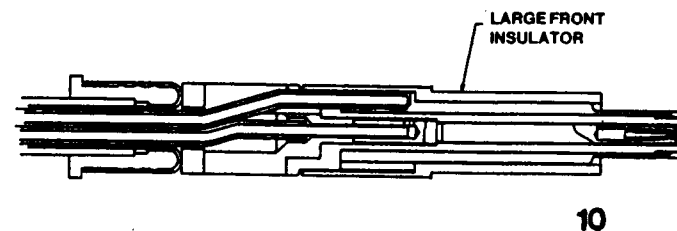
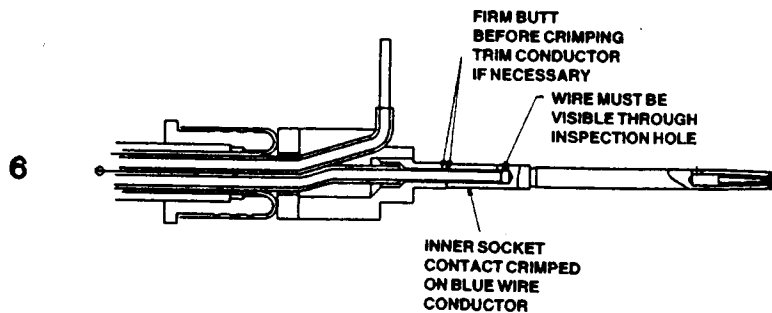

EQUIVALENT APPLICATION TOOLS		
DIE SET	POSITIONER	CONTACT REMOVAL
M22520/5-200	M22520/2-37	DANIELS DRK 264-8
OR	OR	
BENDIX® 11-12101	BENDIX® 11-12102	
OR	OR	
DANIELS Y631	DANIELS K709	