

21-33198-3

21-33198-3

21-33198-3

Contact, Pin, Triaxial Type LJT-R and TV-R Crimp
(MIL-C-38999 Series I & III Electrical Connectors)

Standard contact arrangements available in Series I and III are 17-2, 21-75, 21-79, 25-7, 25-17, 25-26 and 25-46. Contact is supplied with a piggyback grommet seal.

Installation Instructions

1. Slide piggyback grommet seal over the cable jacket, soft rubber end first.
2. Slide the outer crimp bushing, flange end first, over the outer cable jacket. Secure in place with a piece of tape that can be removed later.
3. Strip cable outer jacket .850 inches as shown. Do not cut or nick shield wire strands under jacket.
4. Strip cable shield to .350 inches from end of crimp bushing and carefully form strands back over crimp bushing as evenly as possible. Do not comb out the shield strands.
5. Trim the shield strands even to .015 inch max from front of crimp bushing forward flange.
6. Slide insulator spacer bushing, flange end first, over the cable interlayer and butt firmly against the shield strands formed over the crimp bushing end.
7. Slide the intermediate crimp bushing, flange end first, over the cable interlayer and firmly butt against the insulator spacer bushing.
8. Strip cable interlayer ahead of intermediate crimp bushing. Use caution not to cut or nick the inner shield wire strands under the interlayer.
9. Trim cable inner shield to .110 inches ahead of the intermediate crimp bushing end and carefully form strands back over crimp bushing as evenly as possible. Do not comb out the shield strands.
10. Trim shield strands even to .015 inches from front of intermediate crimp bushing flange.
11. Strip cable core .100 inches from shield formed over intermediate crimp bushing end. Do not cut or nick strands of cable center conductor when removing cable core insulation.
12. Slide front insulator, large end first, over cable center conductor and cable core until insulator butts firmly against the cable shield that is formed over the intermediate crimp bushing end. Be sure all strands of the cable center conductor appear through the end of the front insulator and that no cable intermediate shield strands have entered the rear opening of the front insulator. (An electrical check at this time may be performed to insure electrical isolation. Also after step 13.)
13. Trim fit the inner pin contact to the cable center conductor. The inner pin contact must butt against the end of the front insulator and the cable center conductor must be visible in the inner pin contact wire well inspection hole.
14. Crimp inner pin contact to cable center conductor using tool part number M22520/2-01 and Daniels Mfg. Co. tool contact positioner part number "K873". The tool indenter selector setting shall be "3".
15. Carefully slide the intermediate socket contact with its insulator installed, over the inner pin contact, front insulator and on over the intermediate crimp bushing and shield until the inner pin contact is firmly seated in the insulator recess of the intermediate contact end, due to contact and assembly tolerances.
16. Crimp intermediate contact and bushing flange simultaneously using tool frame part number M22520/5-01 and die set part number M22520/5-05 closure "B" (.178 hex). Observe the .325 crimp length shown.
CAUTION: DO NOT PULL ON THIS ASSEMBLY AFTER CRIMPING.
17. Slide outer pin contact with insulator already installed, over the crimped intermediate socket contact, spacer insulator bushing and shield formed over rear crimp bushing, until intermediate socket contact is fully seated in the outer contact insulator recess. A small gap may appear between the crimp bushing front flange and the outer pin contact end due to contact and assembly tolerances.
18. Crimp the outer pin contact and crimp bushing simultaneously using tool frame part number M22520/5-01 and die set part number M22520/5-45 die closure "A" (.231 hex). Observe the .240 - .270 crimp length shown. (Remove tape used to hold crimp bushing in position on cable during assembly).

CONTACT INSERTION INTO CONNECTOR

Hand insert the contact assembly through proper grommet opening until contact firmly seats inside the connector insert cavity. Tug slightly on cable to insure contact has properly seated in the insert retention device. Slide the piggyback grommet seal down the cable until the hard plastic portion comes to a firm butt inside the grommet cavity.

CONTACT REMOVAL FROM CONNECTOR

Slide the piggyback grommet seal up the cable and out of connector grommet cavity approximately 1.000 inch. Position Daniels Mfg. Co. removal tool part number "DRK264-B" around the cable jacket and slide tool down the cable until tool tips enter the rear grommet and come to a positive stop. Hold the tool tip firmly against the positive stop on the contact and grip the cable jacket and simultaneously remove tool, contact and cable.

L-1254-F
April 1997

FSCM 77820

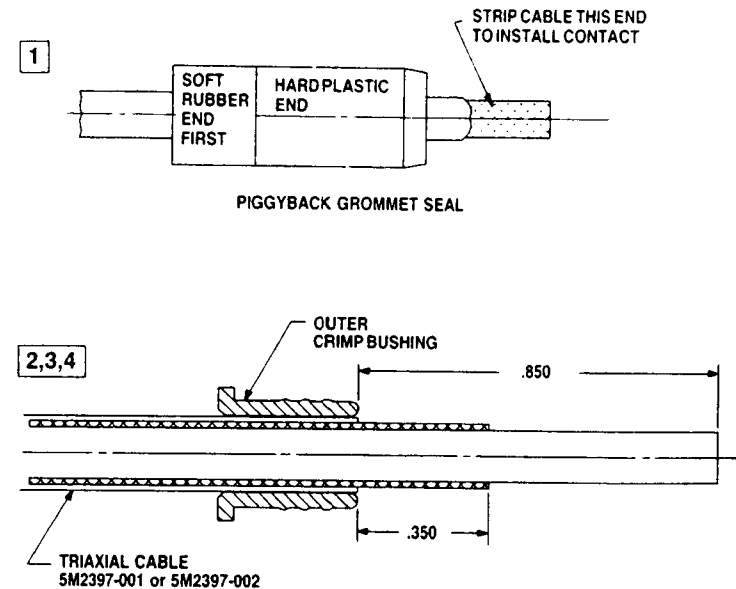

Amphenol

AMPHENOL CORPORATION
Amphenol Aerospace
40-60 Delaware Avenue
Sidney, New York 13838-1395

