

21-33123-587

Contact, Socket, Coaxial Type LJT-R, TV-R, Crimp (MIL-C-38999 Series I & III)
Installation Instructions

See table on reverse side for coaxial cable recommended, type assembly instructions code, stripping dimensions, tool selector settings, crimping tool, positioner and insertion/removal tool information.

Type
Assy. Figure

- I A Strip cable as illustrated. Ends must be cut cleanly and at right angles to the axial plane of the cable. The cable must not be deformed while making cuts. Hot wire stripping is recommended.
- I B
 1. Slide shield crimp sleeve over cable jacket.
 2. Carefully unravel and flair back strands of outer shield and strip cable dielectric.
- I C
 1. Slide rear insulator over cable center conductor and under cable shield until dielectric bottoms against rear insulator recess.
 2. Slide inner pin contact over cable center conductor. Cable center conductor must be visible through the inspection hole in the inner pin contact wire well.
 3. Crimp inner pin contact wire well using crimp tool and positioner listed in table on back.
- I D Slide outer contact over inner pin assembly and under cable shield until inner pin contact and front insulator are fully seated.
- I E
 1. Bring shield crimp sleeve forward over cable shield and observe .240 - .270 dimension. Trim excess shield ahead of shield crimp sleeve.
 2. Crimp shield crimp sleeve using tool and positioner listed in table on back as follows: Crimp once, rotate the contact assembly 45° and crimp a second time. After crimping the second time, the diameter over the shield crimp sleeve must not be greater than .156.

Contact Insertion

Using insertion tool (see table on back), insert contact assembly into rear connector grommet hole. Contact must be aligned with hole and not inserted at an angle. Push forward until contact is felt to snap into position within insert. Remove tool.

Contact Removal

Position removal tool (see table on back), around cable and slide tool down wire until tool tips enter rear grommet and come to a positive stop. Hold tool tip firmly against positive stop on contact, grip wire and simultaneously remove tool, contact and cable.

21-33123-587

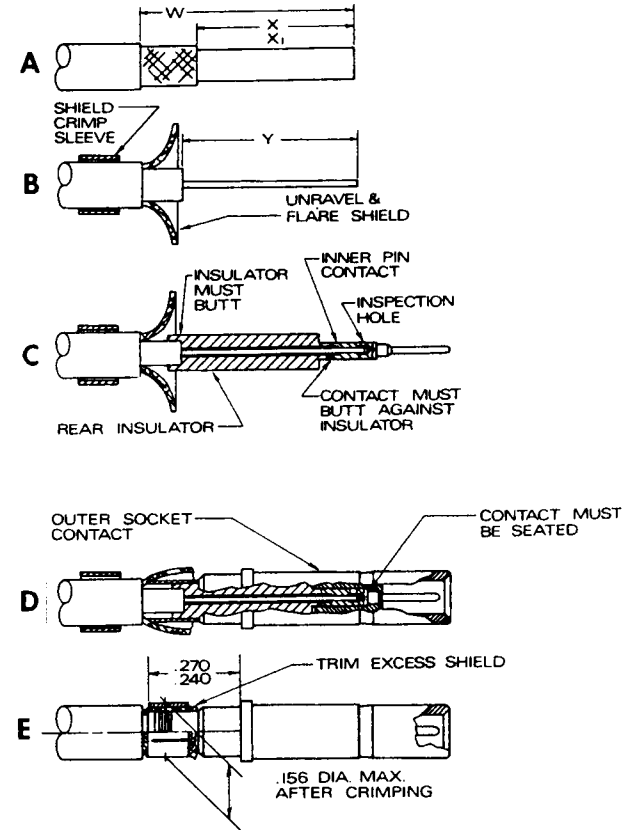

Amphenol Aerospace

PART NO.	COAXIAL CABLE ACCOMODATED	TYPE ASSEMBLY INSTRUCTIONS	STRIPPING DIMENSIONS				TOOLS						
			W	X	Y	X ₁	INNER CONTACT			OUTER CONTACT			
							TOOL SELECTOR SETTING NO.	BASIC CRIMPING TOOL	POSITIONER	BASIC CRIMPING TOOL	POSITIONER	INSERTION TOOL	REMOVAL TOOL
21-33123-587	5M2868-001	I	.680	480	530	-	3	M22520/2-01	M22520/2-34 OR K323 (DANIELS)	M22520/31-01 OR GS200 (DANIELS)	M22520/31-02 OR G2P330 (DANIELS)	M81969/8-09 OR M81969/14-04	M81969/8-10 OR M81969/14-04