

21-33213-41 (PIN) JN1104P50C
21-33214-41 (SOCKET) JN1104S50C

Contact, Pin and Socket, Coaxial, Type TV-R, Crimp, Size 12
Installation Instructions

See table on reverse side for coaxial cable recommended, crimp tool and insertion/removal tool information.

- A. 1. Slide outer crimp ferrule over cable outer jacket as shown.
 2. Strip cable outer braid as illustrated. Ends must be cut cleanly and at right angles to the axial plane of the cable. The cable must not be deformed while making cuts.
 3. Flare outer braid, then strip cable dielectric as shown.
- B. 1. Assemble captivating bushing over cable center conductor and cable dielectric until inside bore of bushing butts against cable dielectric.
 2. Assemble inner contact over cable center conductor until inner contact butts against captivating bushing. Cable center conductor must be visible through the inspection hole in the inner contact wire well.
 3. Crimp inner contact wire well using crimp tool listed in table.
- D. 1. Carefully slide outer contact assembly over inner contact and under cable outer braid, until inner contact butts against insulator shoulder as illustrated.
 2. Bring outer crimp ferrule forward over cable outer braid. Trim excess braid ahead of crimp ferrule, if necessary.
 3. Crimp outer crimp ferrule using crimp tool listed in table. Crimp once, rotate the contact assembly 45° and crimp a second time. After crimping the second time, the diameter over the ferrule must not be greater than .156.

CONTACT INSERTION INTO CONNECTOR

Using insertion tool (see table), insert contact assembly into rear connector grommet hole. Contact must be aligned with hole and not inserted at an angle. Push forward until contact is felt to snap into position within insert.

CONTACT REMOVAL FROM CONNECTOR

Position removal tool (see table) around cable and slide tool down wire until tool tips enter rear grommet and come to a positive stop. Hold tool tip firmly against positive stop on contact, grip wire and simultaneously remove tool, contact and cable.

L-2092-B
 May 1998

FSCM77820

21-33213-41 (PIN) JN1104P50C
21-33214-41 (SOCKET) JN1104S50C

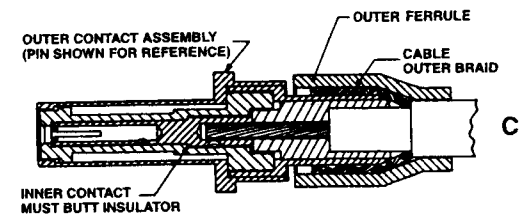
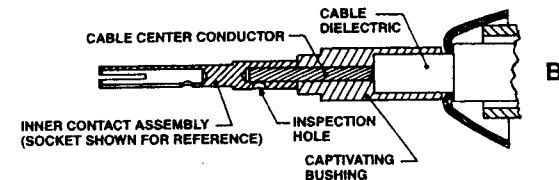
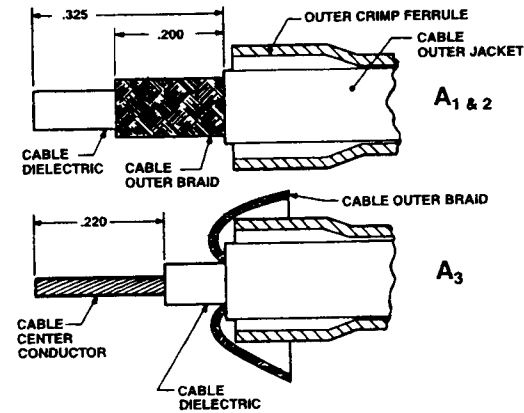

Amphenol Aerospace

AMPHENOL CORPORATION
 Amphenol Aerospace
 40-60 Delaware Avenue
 Sidney, New York 13838-1395

Part Number	Coaxial Cable Accommodated*	Tools				
		Inner Contact		Outer Contact		
		Crimp Tool	Positioner/ Positioner Setting	Crimp Tool Assembly or Crimp Tool and Positioner	Insertion Tool	Removal Tool
21-33213-41	JN1088WT	M22520/2-01	K1105 Setting 3	GS200 or GS200-1 and G2P330	M81969/8-09 or M81969/14-04	M81969/8-10 or M81969/14-04
21-33214-41	JN1088WU	MH992	K1105 Setting 5			

* Terminates the inner coaxial portion of JN1088 triax cables.