

CF-9013

CF-9013

Size 20 Single Mode Fiber Optic Termini
CF-198082-(), CF-198083-()
Cable Installation Instructions

WARNING NOTE:

Caution: Looking into fibers illuminated with laser light can cause eye damage. Follow safety procedures recommended by light source manufacturers.

Extreme care should be taken when handling glass fiber to avoid penetration of skin.

1. Ref. drawings CF-198082-CD and CF-198083-CD for identification and orientation of parts. Visually inspect cable for optical continuity.
2. Slide shrink tube back onto cable.
3. Strip cable to indicated dimensions.

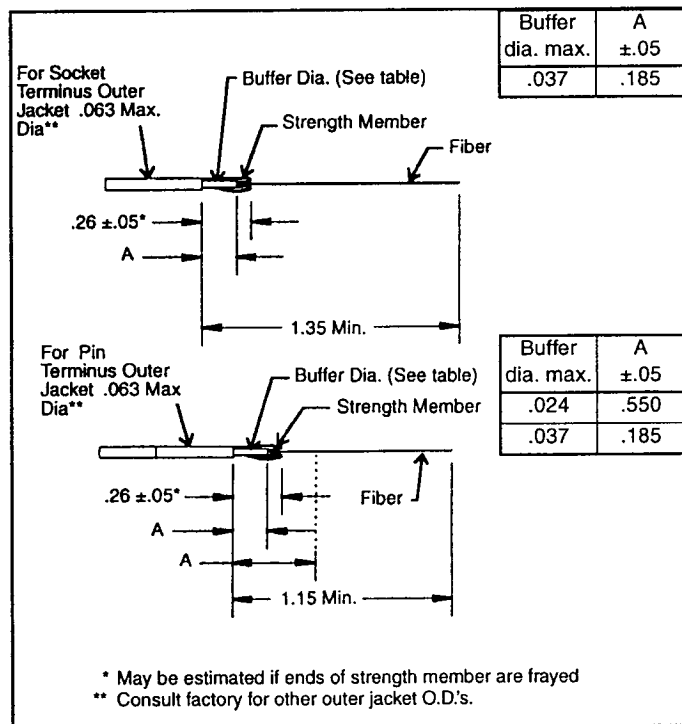

4. Wipe off bare fiber with MEK or equivalent. Fiber surface must be clean and dry before bonding.
5. Test fit to ensure proper hole size by pushing fiber into terminus until it becomes visible on the ceramic end.
6. Prepare epoxy per manufacturer's instructions.
Recommended Epoxy: 200°C Max Service Temp.; #353ND
Suggested Source:
Epoxy Technologies, Inc.
P.O. Box 567
Billerica, MA 01865
7. Fill syringe with epoxy.
8. Insert syringe into back of terminus until it bottoms out on ceramic. Syringe will not bottom out on ceramic in socket termini. Inject epoxy into ceramic capillary until a small bead develops at the tip of ceramic.

9. Wipe bare fiber with epoxy. **Use epoxy sparingly** (should resemble dew on a spider web).
10. Add epoxy to outside rear end of terminus (.047 dia.) for approximately .150. This is to ensure bonding of the strength member to the terminus body. Carefully push stripped fiber into terminus until the buffer bottoms out on the inner body or rear of ceramic (depending on cable type). Outer jacket will be approximately .060 from the rear of terminus. Bare fiber should be protruding out the front of terminus. There should be a small bead of epoxy on the tip of the ceramic. Add epoxy to end of outer jacket of cable for approximately .150 to ensure sealing to shrink tube. Evenly distribute strength member over rear of terminus. Bring up shrink tube to position shown in reference drawing. (see step 1)

Note: Neither shrink tube or strength members should be on .069 diameter.

11. Shrink tube using heat gun. Heat gun to be rated at 300°-400°C air-flow temperature. Do not apply excessive heat to F.O. cable jacketing. Epoxy will turn dark amber color at full cure. Once fully cured, remove heat immediately. Repeat for other fibers.
12. To cure the epoxy at the front of the terminus between fiber and ceramic, follow either of the approved procedures listed below:
 - A. When using a heat gun at recommended temperature. Insert end of ceramic and fiber into air-flow for ten (10) one-second intervals.
 - B. When using a step-cure oven. Step cure per the following cure schedule:

Temp. (°C)	Duration (minutes)
80	120
125	120
150	120

13. Scribe glass fiber approximately .010 above epoxy bead. Grasp fiber and pull slightly until fiber breaks.

Note: Extreme care must be taken when cleaving fiber to ensure fiber is not recessed in ceramic.

14. Place a piece of 15 micron lapping film (approx. 8 X 3 inches long) between the fingers in your hand and hold to form a slight concave radius in it. Using light pressure glide the film over the tip of the terminus in a circular motion. Continue until the dark amber epoxy bead at the tip is nearly worn away. The tip will have a light brown color where the epoxy is. This step will reduce the fiber length for final polishing. **NOTE: Do not polish away all epoxy in this step. This will result in scratching of the ceramic and possible fiber undercut.**

15. Thoroughly clean termini.
16. The fully cured termini may either be machine polished (recommended) or hand polished. Reference the following lists to determine which polishing fixture to use:

Hand Polishing

Note: Although hand polishing is not preferred, with practice it is possible to achieve an acceptable finish if extreme care is taken.

Use hand polishing fixture (Amphenol P/N 11-12153) when polishing either CF-198082-() or CF-198083-(). This fixture will polish one termini at a time.

Machine Polishing

MACHINE POLISH STILL BEING DEVELOPED

Hand Polishing

17. Install terminus into bottom fixture. Screw on appropriate top fixture, captivating terminus.

18. Using a "figure-8" motion and enough pressure to overcome spring force of the polishing tool, polish terminus on .3 micron aluminum oxide lapping film backed by a 90 durometer pad. Moisten entire polishing surface of film with isopropyl alcohol when performing this step. Perform approximately 75-100 small figure 8's. Slowly work up and down the film while polishing. (See figure below):

Work up and down paper while polishing

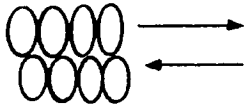

19. Inspect end of the optical fiber for desired finish using a microscope. (See figure below).

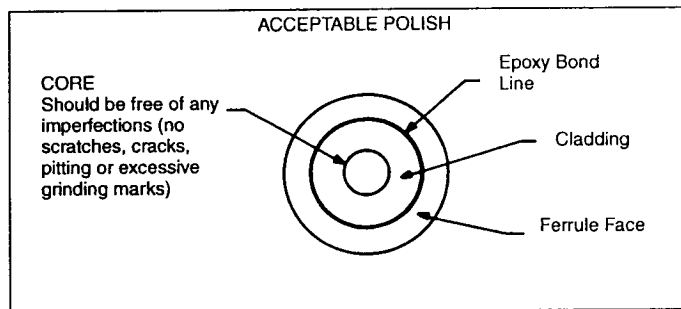

Note: It is recommended that an interferometer check follow hand polishing to insure that fiber height (spherical) is -0.05 micron to $+0.05$ micron. If fiber height (spherical) is over $+0.05$ micron, perform figure 8's in 20 sweep intervals on isopropyl alcohol moistened .3 micron aluminum oxide film backed by a 90 durometer pad and then retest.

If fiber height (spherical) is below -0.05 micron, perform figure 8's in 20 sweep intervals on isopropyl alcohol moistened 1 micron silicon carbide film backed by a 90 durometer pad, then on isopropyl alcohol moistened .3 micron aluminum oxide film backed by a 90 durometer pad, and then retest. Recommended radius of curvature is 4-30 mm. Apex offset <50 microns.

If undercut is too severe, polish terminus on 1 micron carbide film backed by a glass plate until fiber and ceramic are flat. Polish on 1 micron silicon carbide film backed by a 90 durometer pad to form desired radius of curvature. Polish terminus on isopropyl alcohol moistened .3 micron aluminum oxide film backed by a 90 durometer pad to produce desired finish and retest.

20. Thoroughly clean termini and fixture. Push on protection cap, when supplied. Cap must be removed before inserting termini into connector.

21. For socket terminus only:

Before installing protection cap, push alignment sleeve onto socket terminus until fully seated.

22. Push termini into connector until fully seated. Care should be taken not to exceed minimum bend radius of buffered fiber. If desired, insertion tool M81969/14-10 may be used to aid assembly. For removal of termini, use extraction half of supplied tool.

Machine Polishing

Please contact Amphenol, Sidney, NY for update on machine polishing instructions.

Recommended Equipment

Hand Polishing

- Razor blade and/or exacto knife
- Glass plate
- 90 durometer rubber pad
- MEK
- Isopropyl alcohol
- Epoxy, as required
- 1 syringe, .024 max. dia. needle
- Polishing fixture: 11-12153 (hand polishing)
- 15 micron & .3 micron aluminum oxide lapping film
- 1 micron silicon carbide lapping film
- Microscope, 100 power or greater
- Cotton swabs
- Small scissors
- Cutting pliers
- Wire strippers or hot tweezers, depending on cable type
- .014 no nik wire strippers or equivalent
- Hot air gun (air flow temp 300-400°C)
- Fiber scribe
- Interferometer