

10-610348-00P (PIN), 10-610351-00P (PIN)
10-610348-00S (SOCKET), 10-610351-00S (SOCKET)

Contact, Pin and Socket, Quadrax, Special
 Installation Instructions

See table on reverse side for quadrax cable recommended, tool selector settings, crimping tool and positioner information.

- A** 1. Cut cable for assembly of quadrax contacts.
 Note: Contact assemblies of opposite gender should be assembled at cable junction adjacent ends, to have inner wire conductors in correct orientation during contact assembly. Crossing of inner wires from their natural lie position is not permissible.
- B** 1. Strip cable jacket to expose cable outer braid as illustrated. Ends must be cut cleanly and at right angles to the axial plane of the cable. Cable must not be deformed while making cuts.
- C** 1. Slide crimp bushing, large diameter end first, over cable braid until cable jacket butts inside shoulder of crimp bushing.
- D** 1. Flair cable braid back over crimp bushing as illustrated to expose inner wires. Trim excess cable braid.
2. Cut off any inner braids, wraps or cable fillers as close to outer cable braid as possible.
3. Cut inner wires to dimension shown. All wires must be cut to equal length. It may be helpful to cut one wire to length. Then, one at a time, cut remaining wires to equal length as the first wire.
- E** 1. Strip inner wires to expose center conductors as illustrated. All wires must be stripped to equal length.
- F** 1. Carefully splay inner wires perpendicular to the axis of the cable as illustrated.
2. Assemble inner contact over cable center conductor until fully seated against inner wire insulation. Observe center conductor through the contact's wire inspection hole, to make certain conductor is properly positioned.
3. Crimp inner contact to center conductor using crimp tools listed in table on back. Repeat steps F2 and F3 until all inner contacts are crimped.
- G** 1. Position rear insulator against cable braid as illustrated. Make certain insulator slots are aligned with splayed inner contact wires. One-by-one, position wired inner contacts inside the insulator slots as shown. The inner contact's retention shoulder must be positioned in front of the insulator's front surface as illustrated.

Continued on back

L-2119-AT
 August 2005

FSCM77820

10-610348-00P (PIN), 10-610351-00P (PIN)
10-610348-00S (SOCKET), 10-610351-00S (SOCKET)

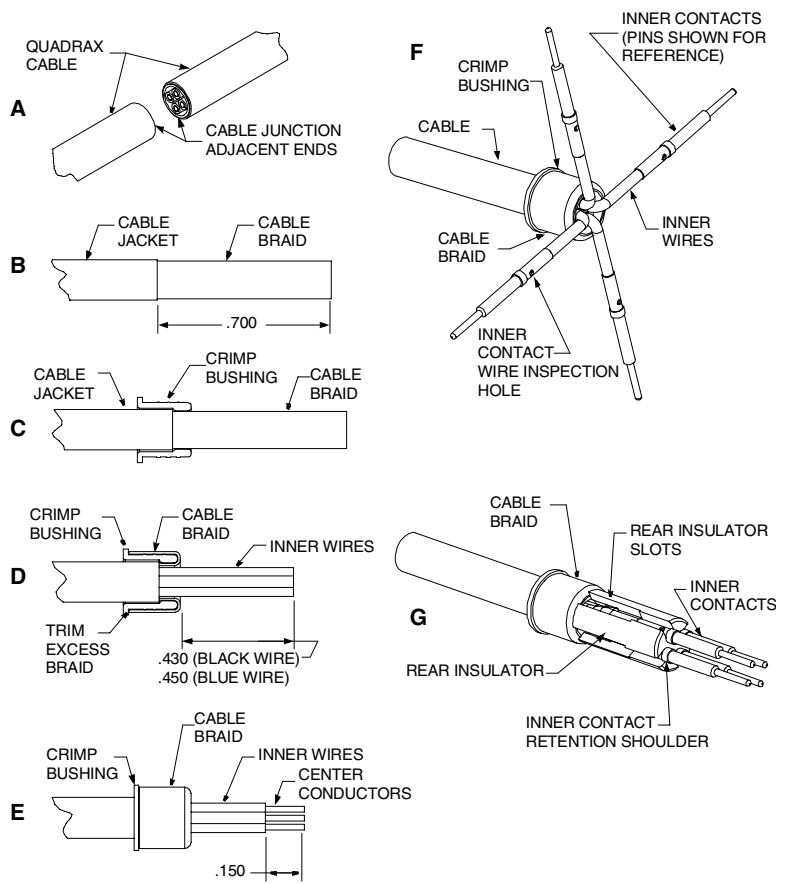

10-610348-00P (PIN), 10-610351-00P (PIN)
10-610348-00S (SOCKET), 10-610351-00S (SOCKET)

- H
1. With inner contacts positioned inside rear insulator slots, assemble front insulator over the inner contacts as shown. The front insulator must butt the rear insulator, and inner contact retention shoulders must enter front insulator bores.
 2. Observe the front insulator's keyway. When the inner pin contact with the insulator keyway to its right will be positioned adjacent to and in alignment with the outer contact's orientation key (for inner socket contacts, the insulator keyway should be positioned to the left of the inner socket desired adjacent to and in alignment with the outer contact's orientation key).
- I
1. Align front insulator keyway with the outer contact's rivet key. Slide the inner contact assembly inside the outer contact body until fully seated. Observe the mating end of the assembly to make certain one pair of inner contacts are in vertical alignment with the outer contact's orientation key.
 2. Crimp outer contact body in the area indicated using crimp tools listed in table below.

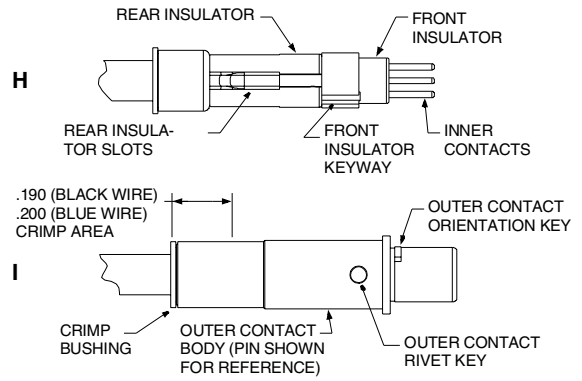

Amphenol Part Number	Description	Quadrax Cable Recommended	Color Wire	Inner Crimp Tools		Outer Crimp Tools	
				Tool (Setting)	Positioner	Tool	Die Set (Location)
10-610348-00P	Quadrax Pin (120 Phms)	Nexans EDE 2PE993 (.5mm ²)	Blue	M22520/2-01 (-5)	Daniels K1625	M22520/5-01	Daniels Y144
10-610348-00S	Quadrax Socket (120 Ohms)	Nexans EDE 2PE933 (.5mm ²)	Blue				
10-610351-00P	Quadrax Pin	Filotex P 2PG041 (.75mm ²)	Black				
10-610351-00S	Quadrax Socket	Filotex P 2PG041 (.75mm ²)	Black				

Contact Insertion into Connector

Contacts are inserted by hand. Insert the contact assembly into the proper shell/insert hole. The contact's orientation key must be aligned with the shell/insert contact hole keyway. Push contact forward until fully seated. With all required contacts correctly positioned, slide contact retainer disk forward and assemble retainer screw.

Amphenol

Amphenol Aerospace
 40-60 Delaware Avenue
 Sidney, New York 13838-1395
 Website: www.amphenol-aerospace.com