

21-33837-331 (PLUG)

Transition Adapter, Plug, Quadrax
Type High Speed, to Board,
Installation Instructions

See table on reverse side for quadrax cable recommended and crimping tool information.

- A 1. Cut cable for assembly of transition adapter plug.
- B 1. Strip cable jacket to expose cable outer braid as illustrated. Ends must be cut cleanly and at right angles to the axial plane of the cable. Cable must not be deformed while making cuts.
- C 1. Slide crimp bushing, flange end first, over the outer cable jacket until front is flush with jacket cut edge. Secure in place with a piece of tape that can be removed later.
- D 1. Flair cable braid back over crimp bushing as illustrated to expose inner wires. Trim excess cable braid.
2. Cut off any inner braids, wraps or cable fillers as close to outer cable braid as possible.
3. Cut inner wires to dimension shown. All wires must be cut to equal length. It may be helpful to cut one wire to length. Then, one at a time, cut remaining wires to equal length as the first wire.
- E 1. Strip inner wires to expose center conductors as illustrated. All wires must be stripped to equal length.
- F 1. Carefully splay inner wires perpendicular to the axis of the cable as illustrated.
2. Assemble inner contact over cable center conductor until fully seated against inner wire insulation. Observe center conductor through the contact's wire inspection hole, to make certain conductor is properly positioned.
3. Crimp inner contact to center conductor using crimp tools listed in table on back. Repeat steps F2 and F3 until all inner contacts are crimped.
- G 1. Position rear insulator against cable braid as illustrated. Make certain insulator slots are aligned with splayed inner contact wires. One-by-one, position wired inner contacts inside the insulator slots as shown. The inner contact's retention shoulder must be positioned in front of the insulator's front surface as illustrated.

L-2119-EV
January 2014

FSCM77820

21-33837-331 (PLUG)

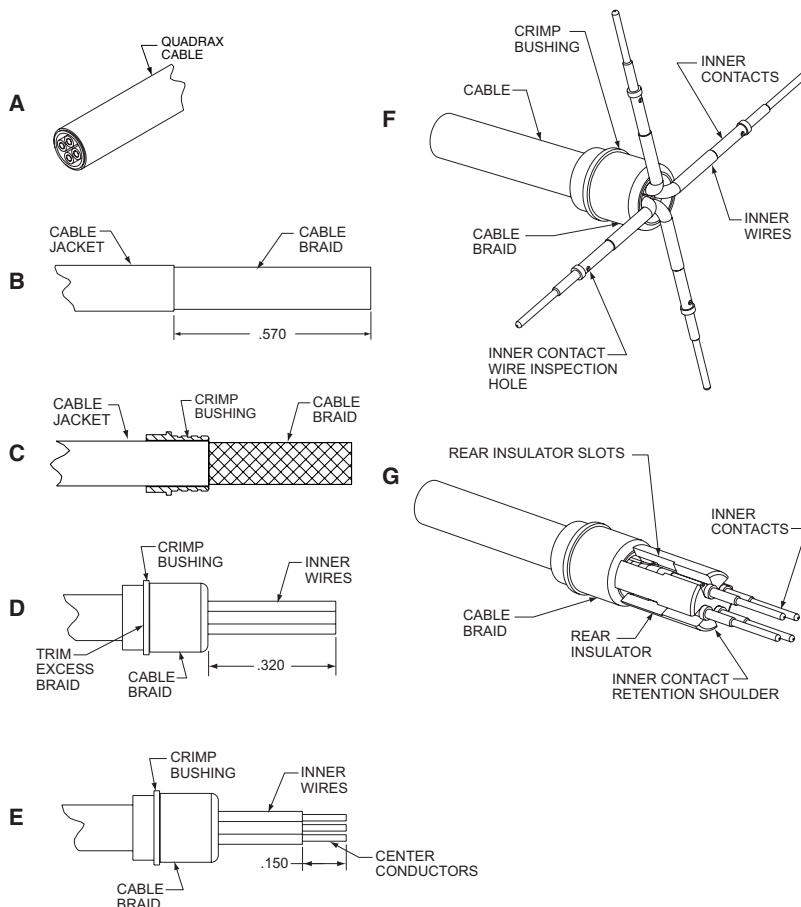

21-33837-331 (PLUG)

- H 1. With inner contacts positioned inside rear insulator slots, assemble front insulator over the inner contacts as shown. The front insulator must butt the inner contact retention shoulders.
2. Observe the front insulator's keyway. When the inner assembly is held in the vertical position (with inner contacts on top), the inner contact to the left of the insulator keyway will be positioned at the S1 inner contact position shown in View I.
- I 1. Align front insulator keyway with the outer contact's rivet key. Slide the inner contact assembly inside the outer contact assembly until fully seated. Observe the mating end of the assembly to make certain contacts are aligned as shown (Ref 45 degrees).
2. Crimp outer contact body in the area indicated using crimp tools listed in table below. (Remove tape used to hold crimp bushing in position on cable during assembly.)

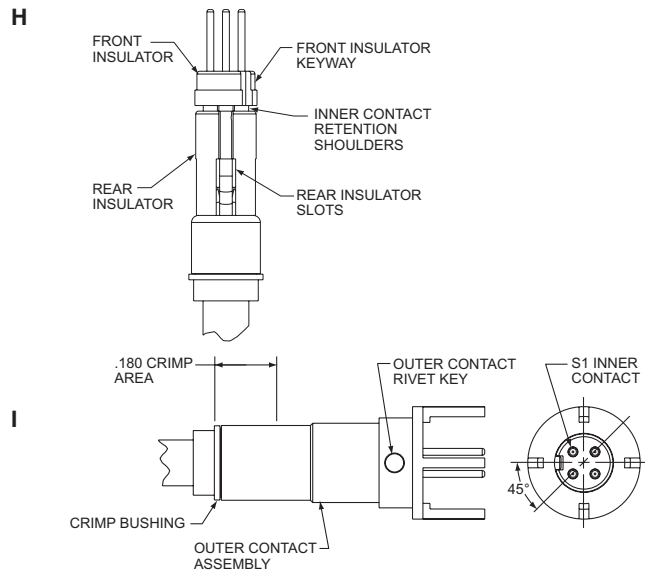

Amphenol Part Number	Description	Twinax Cable Recommended	Inner Crimp Tools		Outer Crimp Tools	
			Tool (Setting)	Positioner	Tool	Die Set (Location)
21-33837-331	Quadrax Transition Adapter Plug (100 Ohm)	W.L. Gore RCN 8647	M22520/2-01 (5)	M22520/2-37 (Daniels K709)	M22520/5-01	M22520/5-45 (A)

Amphenol

Amphenol Aerospace
40-60 Delaware Avenue
Sidney, New York 13838-1395
Website: www.amphenol-aerospace.com