

21-033470-111 (PIN)
21-033471-111 (SOCKET)

Contact, Pin and Socket, Quadrax, Split Pair,
 Type M38999 Series I & III Special, Size 8 Installation Instructions
 See table on reverse side for quadrax cable recommended, tool selector settings,
 crimping tool, positioner and insertion/removal tool information.

- A 1. Cut cable for assembly of quadrax contacts.
 Note: Contact assemblies of opposite gender should be assembled at cable junction adjacent ends, to have inner wire conductors in correct orientation during contact assembly. Crossing of inner wires from their natural lie position is not permissible.
- B 1. Rubber end first, slide piggyback grommet seal back over cable jacket (not illustrated).
 2. Strip cable jacket to expose cable outer braid as illustrated. Ends must be cut cleanly and at right angles to the axial plane of the cable. Cable must not be deformed while making cuts.
 3. Comb and flair exposed cable braid. Remove indicated length of inner wire bundle. Do not trim cable braid.
- C 1. Bring cable braid back to cable then "bullet-nose" the front of the cable braid.
 2. Slide and rotate crimp bushing, large diameter end first, over cable braid until cable jacket butts inside shoulder of crimp bushing.
- D 1. Flair cable braid back over crimp bushing as illustrated to expose inner wires. Trim excess cable braid.
 2. Cut inner wires with foils in place to dimension shown. All wires must be cut to equal length. It may be helpful to cut one wire pair to length. Then, cut remaining wire pair to equal length as the first wire pair.
- E 1. Strip individual differential pair foil shields and wraps as close to flaired cable braid as possible. Do not trim drain wires at this time.
 2. Fold drain wires over crimp bushing & flair out to reduce buildup. Trim excess wire.
 3. Strip inner wires to expose center conductors as illustrated. All wires must be stripped to equal length.
- F 1. Carefully splay inner wires perpendicular to the axis of the cable as illustrated.
 2. Assemble inner contact over cable center conductor until fully seated against inner wire insulation. Observe center conductor through the contact's wire inspection hole, to make certain conductor is properly positioned.
 3. Crimp inner contact to center conductor using crimp tools listed in table on back. Repeat steps F2 and F3 until all inner contacts are crimped.
- G 1. Observe the black insulator's keyway. When the inner pin assembly is held in the vertical position (with inner pin contacts on top), the inner pin contact with the

21-033470-111 (PIN)
21-033471-111 (SOCKET)

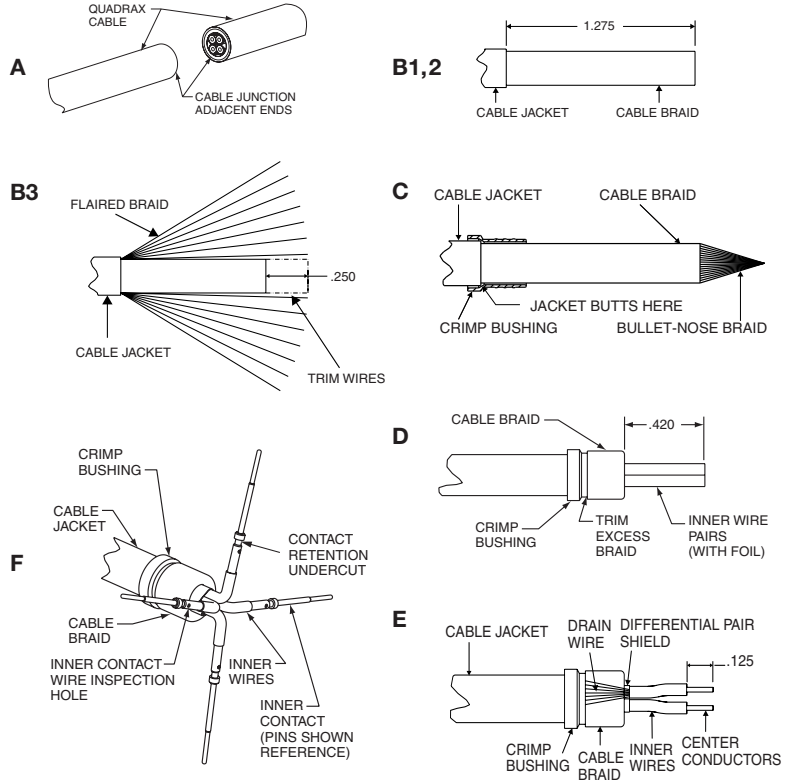

Continued on back
 L-2119-FK
 May 2019

FSCM77820

21-033470-111 (PIN)
21-033471-111 (SOCKET)

- black insulator keyway to its right will be positioned adjacent to and in alignment with the outer contact's orientation key (for inner socket contacts, the black insulator keyway should be positioned to the left of the inner socket desired adjacent to and in alignment with the outer contact's orientation key).
2. With inner contacts approximately aligned with the front insulator contact cavities (pair #1 inner contacts aligned with pair #1 insulator window, pair #2 inner contacts aligned with pair #2 insulator window), assemble front insulator over the inner contacts as shown, being careful to guide the inner contacts through the insulator cavities. The insulator must butt the crimp ferrule, and inner contact retention shoulders must click in front of the retention tines (Inner contacts will lock in place).
 - H 1. Hold insulator sandwich in position and use small pick to remove one "standard" contact retention clip.
 2. Orient "rigid" retention clip such that internal retention features face mating end of contact assembly. Install clip by locking one rib into insulator retention slot then rotate until second rib locks into retention slot on opposite side of insulator. Ensure Contact retention undercut is lined up with retention clip retention features.
 3. Repeat steps 1 and 2 to replace second "standard" retention clip with second "rigid" retention clip
 **Note: it is recommended to apply epoxy to contacts within insulator assembly due to cable "pistoning". Epoxy shall not interfere with inner socket interface nor be present on inner pin mating surfaces
 - J 1. Align black insulator keyway with the outer contact's rivet key. Slide the inner contact assembly inside the outer contact body until fully seated. Observe the mating end of the assembly to make certain inner contacts #1 & #3 are in

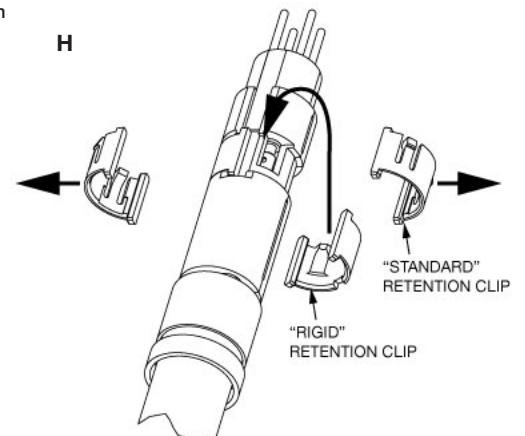
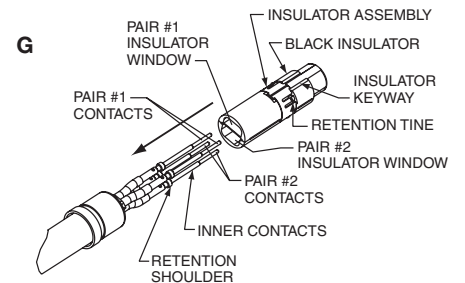

SUGGESTED INNER CONTACT NUMBERING
(MATING END SHOWN)

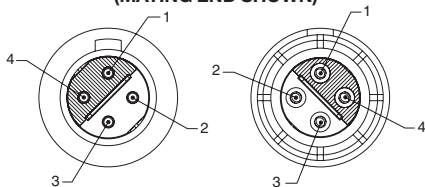

Amphenol Suggested Wiring		
Differential Pair	Inner ID	Wire Color
1	1	Red
	4	Blue
2	2	Yellow
	3	Green

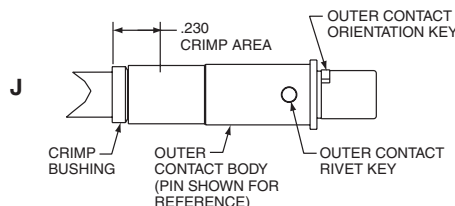

Amphenol

Amphenol Aerospace
 40-60 Delaware Avenue
 Sidney, New York 13838-1395
 Website: www.amphenol-aerospace.com

21-033470-111 (PIN)
21-033471-111 (SOCKET)

vertical alignment with the outer contact's orientation key.

2. Crimp outer contact body in the area indicated using crimp tools listed in table below..

Amphenol Part Number	Description	Quadrax Cable Recommended	Inner Crimp Tools		Outer Crimp Tools	
			Tool (Setting)	Positioner	Tool	Die Set (Location)
21-033470-111	Quadrax Pin (100 Ohm)	W.L. Gore RCN9007-24 (100 Ohm)	M22520/2-01 (4)	Daniels K1777	M22520/5-01	M22520/5-45 (A) or Daniels Y1999 (A)
21-033471-111	Quadrax Socket (100 Ohm)					

Contact Insertion into Connector

Contacts are inserted by hand. Insert the contact assembly into the proper rear grommet hole. Contact must be aligned with hole and not inserted at an angle. The contact's orientation key must be in vertical alignment with the connector's main key or keyway (holding contact key and connector key/keyway at "12 o'clock" orientation position is recommended). Push forward until contact is felt to snap into position within the insert. Contact may need to be slightly rotated to properly align contact orientation key with connector insert keyway. Gently tug on cable to assure retention. Slide piggyback grommet seal into position inside the connector grommet and over the crimped end of the contact.

Contact Removal from Connector

Remove piggyback grommet seal from the connector grommet. Position removal tool part number MIL-I-81969/14-12, Daniels DRK-264-8, around cable and slide tool toward connector until tool tips enter rear grommet and comes to a positive stop on the contact. Grip cable and simultaneously remove tool, contact and cable.

Amphenol

Amphenol Aerospace
40-60 Delaware Avenue
Sidney, New York 13838-1395
Website: www.amphenol-aerospace.com

21-033470-111 (PIN)
21-033471-111 (SOCKET)

Contact, Pin and Socket, Quadrax, Split Pair,
Type M38999 Series I & III Special, Size 8 Installation Instructions
See table on reverse side for quadrax cable recommended, tool selector settings,
crimping tool, positioner and insertion/removal tool information.

- A 1. Cut cable for assembly of quadrax contacts.
Note: Contact assemblies of opposite gender should be assembled at cable junction adjacent ends, to have inner wire conductors in correct orientation during contact assembly. Crossing of inner wires from their natural lie position is not permissible.
- B 1. Rubber end first, slide piggyback grommet seal back over cable jacket (not illustrated).
2. Strip cable jacket to expose cable outer braid as illustrated. Ends must be cut cleanly and at right angles to the axial plane of the cable. Cable must not be deformed while making cuts.
3. Comb and flair exposed cable braid. Remove indicated length of inner wire bundle. Do not trim cable braid.
- C 1. Bring cable braid back to cable then "bullet-nose" the front of the cable braid.
2. Slide and rotate crimp bushing, large diameter end first, over cable braid until cable jacket butts inside shoulder of crimp bushing.
- D 1. Flair cable braid back over crimp bushing as illustrated to expose inner wires. Trim excess cable braid.
2. Cut inner wires with foils in place to dimension shown. All wires must be cut to equal length. It may be helpful to cut one wire pair to length. Then, cut remaining wire pair to equal length as the first wire pair.
- E 1. Strip individual differential pair foil shields and wraps as close to flaired cable braid as possible. Do not trim drain wires at this time.
2. Fold drain wires over crimp bushing & flair out to reduce buildup. Trim excess wire.
3. Strip inner wires to expose center conductors as illustrated. All wires must be stripped to equal length.
- F 1. Carefully splay inner wires perpendicular to the axis of the cable as illustrated.
2. Assemble inner contact over cable center conductor until fully seated against inner wire insulation. Observe center conductor through the contact's wire inspection hole, to make certain conductor is properly positioned.
3. Crimp inner contact to center conductor using crimp tools listed in table on back. Repeat steps F2 and F3 until all inner contacts are crimped.
- G 1. Observe the black insulator's keyway. When the inner pin assembly is held in the vertical position (with inner pin contacts on top), the inner pin contact with the

21-033470-111 (PIN)
21-033471-111 (SOCKET)

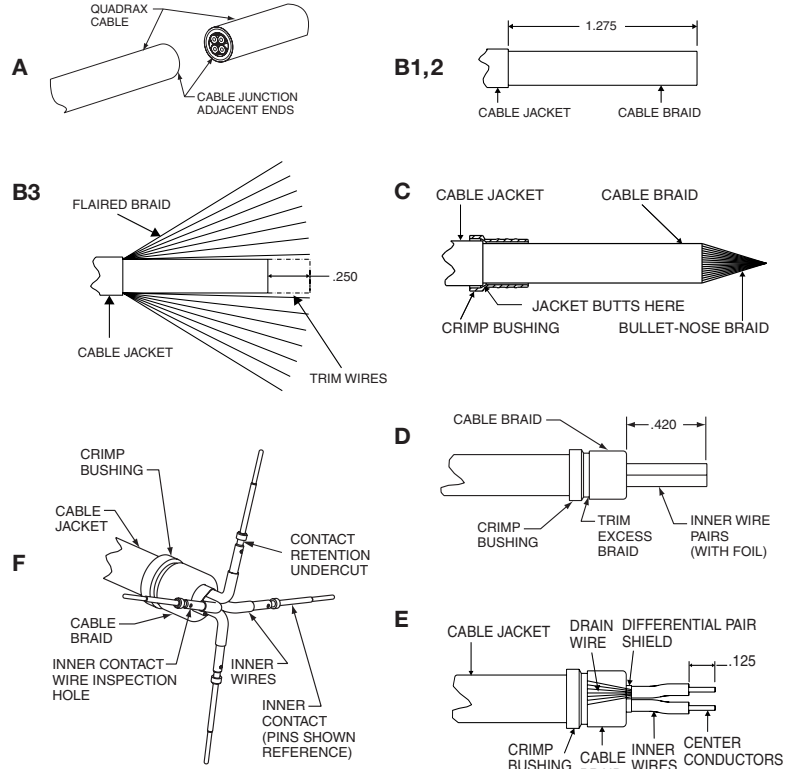

Continued on back
L-2119-FK
May 2019

FSCM77820

Website: www.amphenol-aerospace.com
Sidney, New York 13838-1395

Amphenol Aerospace
40-60 Delaware Avenue
Sidney, New York 13838-1395

Amphenol

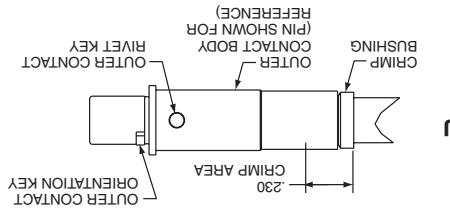

Amphenol Suggested Wiring		Differential Pair	
Wire Color	Inner ID	1	2
Red	1	1	2
Blue	4		
Yellow	2	1	2
Green	3		

SUGGESTED INNER CONTACT NUMBERING (MATING END SHOWN)

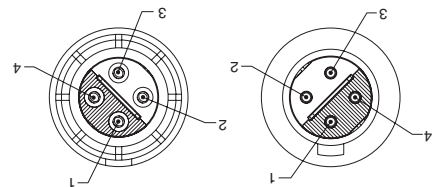

- H 1. Hold insulator sandwich in position and use small pick to remove one "standard" contact retention clip.
2. Orient "rigid" retention clip such that internal retention features face mating end of contact assembly. Install clip by locking one rib into insulator retention slot then rotate until second rib locks into retention slot on opposite side of insulator. Ensure Contact retention undercut is lined up with retention clip retention features.
3. Repeat steps 1 and 2 to replace second "standard" retention clip with second "rigid" retention clip.
**Note: It is recommended to apply epoxy to contacts within insulator assembly due to cable "pistoning". Epoxy shall not interfere with inner socket interface nor be present on inner pin mating surfaces.
J 1. Align black insulator keyway with the outer contact's rivet key. Slide the inner contact assembly inside the outer contact body until fully seated. Observe the mating end of the assembly to make certain inner contacts #1 & #3 are in

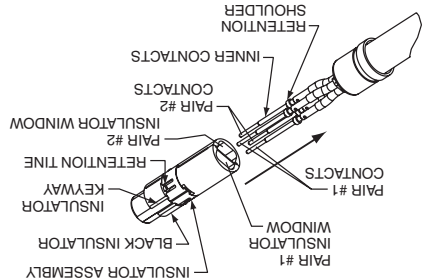
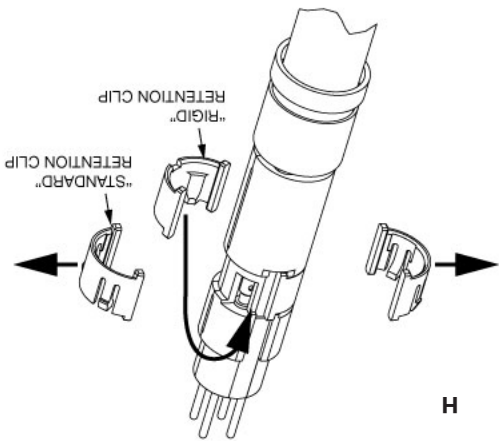

21-033470-111 (PIN)
21-033471-111 (SOCKET)