

21-033585-011 (PIN)
 21-033586-011 (SOCKET)

Contact, Pin and Socket, Differential Twinax
 Type M38999 Series I & III Special, OCS
 Installation Instructions

See reverse side for twinax cable recommended and insertion/removal tool information.

- A 1. Cut cable for assembly of differential twinax contacts.
2. Feed cable through the appropriate hole in the connector's grommet/backshell assembly (not shown) which is supplied with the connector kit.
- B 1. Slide heat shrink (not shown), then shield ferrule back over cable jacket.
2. Strip cable jacket to expose cable outer braid as illustrated. Ends must be cut cleanly and at right angles to the axial plane of the cable. Cable must not be deformed while making cuts.
- C 1. Cut braid to length as illustrated.
- D 1. Comb out braid and split into two approximately even bundles.
2. Flair cable braid back over jacket as illustrated.
3. Cut off any inner braids, wraps or cable fillers as close to cable braid as possible.
- E 1. Strip inner wires to expose center conductors as illustrated. All wires must be stripped to equal length.
- F 1. Carefully insert cable center conductors into solder wells, taking care to maintain indicated length.
2. Solder inner contact to cable center conductor. It may be helpful to pre-tin the wire and solder well.
- G 1. Pre-tin the full length of the outside of the rear "ears" of the outer body.
2. Slide rear insulators into gap between contact/insulator assembly and braid as illustrated. Make certain insulator slots are aligned with inner contacts. Inner contact closest to key on beige rear insulator becomes contact ID #1.
- H 1. Slide outer body over terminated contact/insert assembly and rear inserts until insulator retention tines snap into retention grooves in contact/insulator assembly.
2. Fold braid up onto ears of outer body then slide rear ferrule forward until it bottoms on rear insulator stops.
- I 1. Solder cable braid to outer body and rear ferrule.
2. Slide forward heatshrink and shrink in place to indicated dimension.

Amphenol Part Number	Description	Twinax Cable Recommended
21-033585-011	Differential Twinax Pin (100 Ohm)	W.L. Gore GSC-05-82559-00 (100 Ohm)
21-033586-011	Differential Twinax Socket (100 Ohm)	

Contact Insertion into Connector:

Contacts are inserted by hand. Contact must be aligned with hole and not inserted at an angle. The contact's orientation key (the beige key) must be in alignment with the connector insert's orientation keyway. Push forward until contact is felt to snap into position within the insert. Gently tug on cable to assure retention. Once all contacts are installed in connector, attach grommet/backshell assembly to connector, aligning external key of backshell with the connector main key/keyway. (See images below)

Contact Removal from Connector:

Remove Grommet/Backshell Assembly from rear of connector. Position removal tool part number 10-6460C1-001, around contact at connector mating face. Align removal tool tines with slots in connector insert then slide tool toward connector until tool tips come to a positive stop within the insert. Grip cable and gently pull cable from connector, simultaneously removing contact and cable. Remove tool from mating side of connector. Do not pull contact through grommet cavities, retention tines will damage grommet.

L-2119-FN
 November 2015

FSCM77820

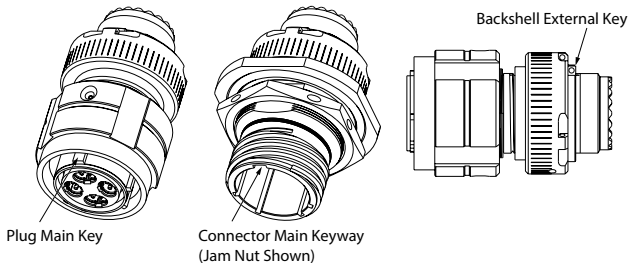

21-033585-011 (PIN)
 21-033586-011 (SOCKET)

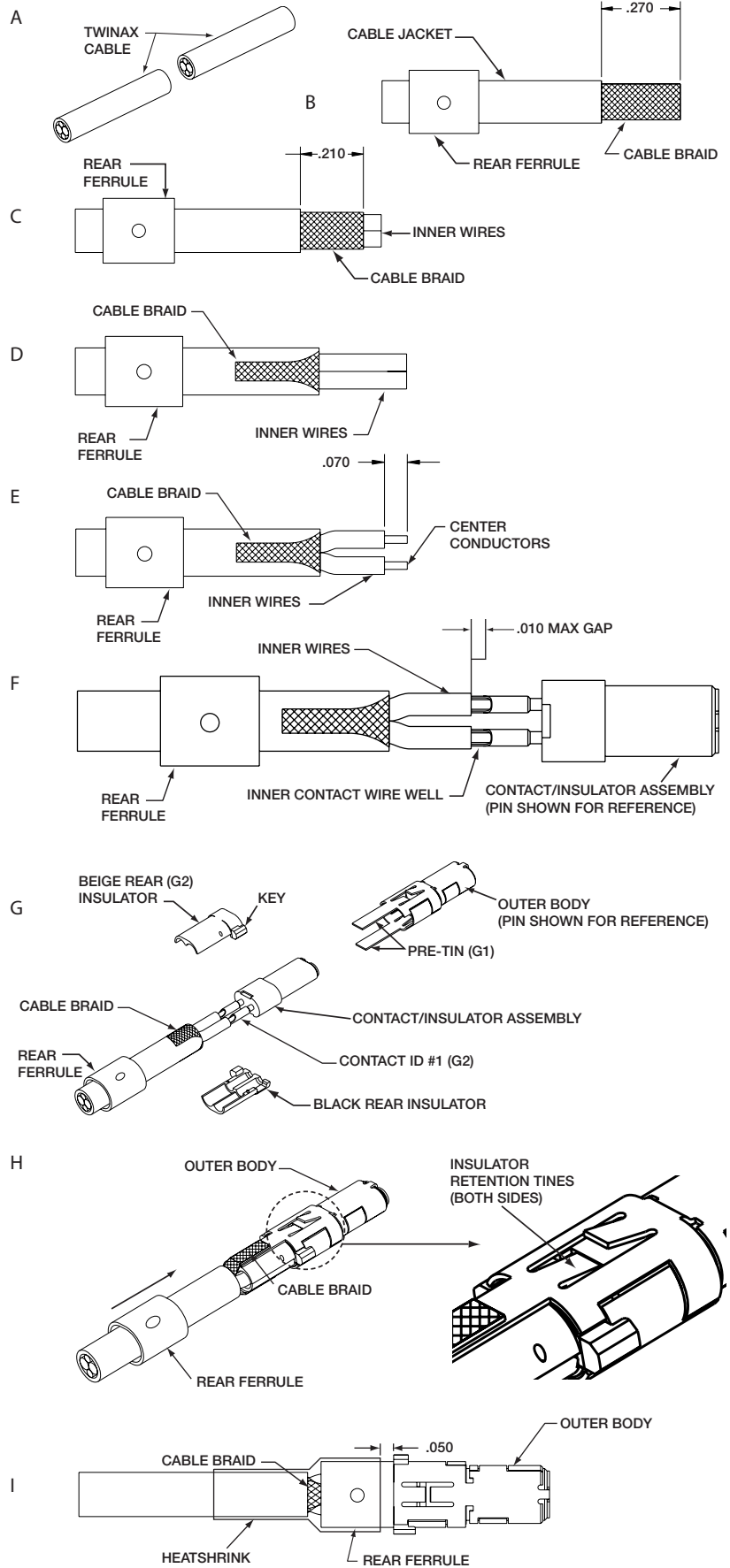

Amphenol

Amphenol Aerospace
 40-60 Delaware Avenue
 Sidney, New York 13838-1395
 Website: www.amphenol-aerospace.com

21-033585-011 (PIN)
21-033586-011 (SOCKET)

Contact, Pin and Socket, Differential Twinax
Type M38999 Series I & III Special, OCS
Installation Instructions

See reverse side for twinax cable recommended and insertion/removal tool information.

- A 1. Cut cable for assembly of differential twinax contacts.
2. Feed cable through the appropriate hole in the connector's grommet/backshell assembly (not shown) which is supplied with the connector kit.
- B 1. Slide heat shrink (not shown), then shield ferrule back over cable jacket.
2. Strip cable jacket to expose cable outer braid as illustrated. Ends must be cut cleanly and at right angles to the axial plane of the cable. Cable must not be deformed while making cuts.
- C 1. Cut braid to length as illustrated.
- D 1. Comb out braid and split into two approximately even bundles.
2. Flair cable braid back over jacket as illustrated.
3. Cut off any inner braids, wraps or cable fillers as close to cable braid as possible.
- E 1. Strip inner wires to expose center conductors as illustrated. All wires must be stripped to equal length.
- F 1. Carefully insert cable center conductors into solder wells, taking care to maintain indicated length.
2. Solder inner contact to cable center conductor. It may be helpful to pre-tin the wire and solder well.
- G 1. Pre-tin the full length of the outside of the rear "ears" of the outer body.
2. Slide rear insulators into gap between contact/insulator assembly and braid as illustrated. Make certain insulator slots are aligned with inner contacts. Inner contact closest to key on beige rear insulator becomes contact ID #1.
- H 1. Slide outer body over terminated contact/insert assembly and rear inserts until insulator retention tines snap into retention grooves in contact/insulator assembly.
2. Fold braid up onto ears of outer body then slide rear ferrule forward until it bottoms on rear insulator stops.
- I 1. Solder cable braid to outer body and rear ferrule.
2. Slide forward heatshrink and shrink in place to indicated dimension.

Amphenol Part Number	Description	Twinax Cable Recommended
21-033585-011	Differential Twinax Pin (100 Ohm)	W.L. Gore GSC-05-82559-00 (100 Ohm)
21-033586-011	Differential Twinax Socket (100 Ohm)	

21-033585-011 (PIN)
21-033586-011 (SOCKET)

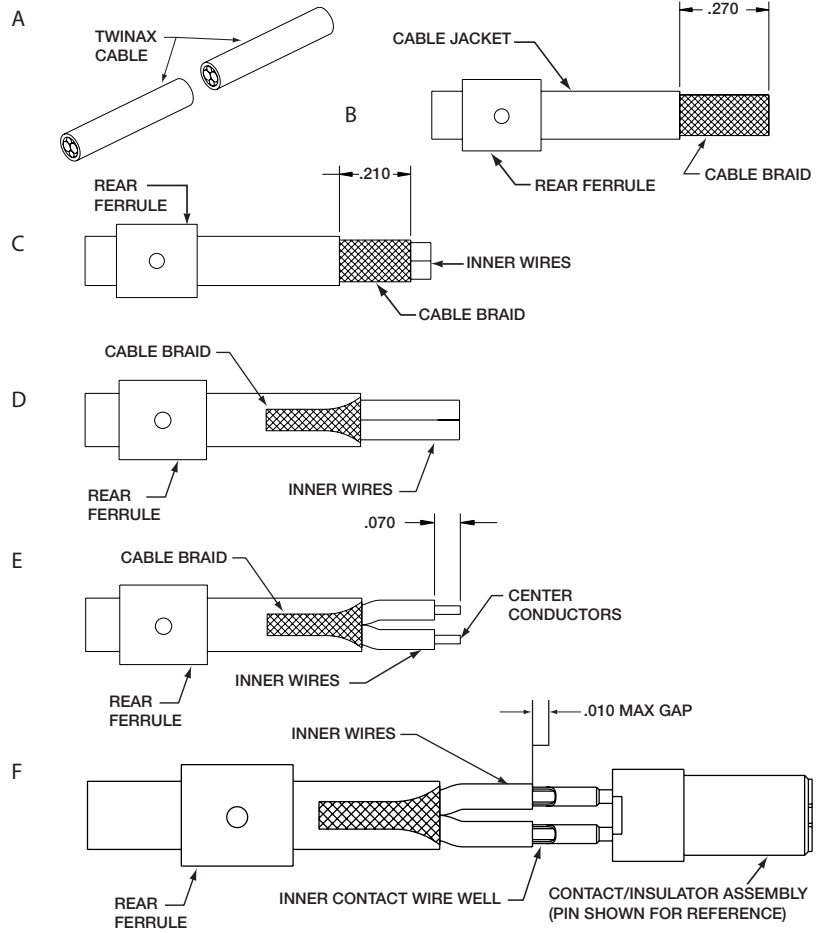

Amphenol Aerospace
40-60 Delaware Avenue
Sidney, New York 13838-1395
Website: www.amphenol-aerospace.com

Amphenol

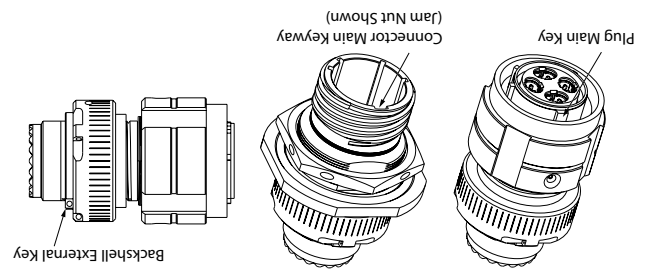
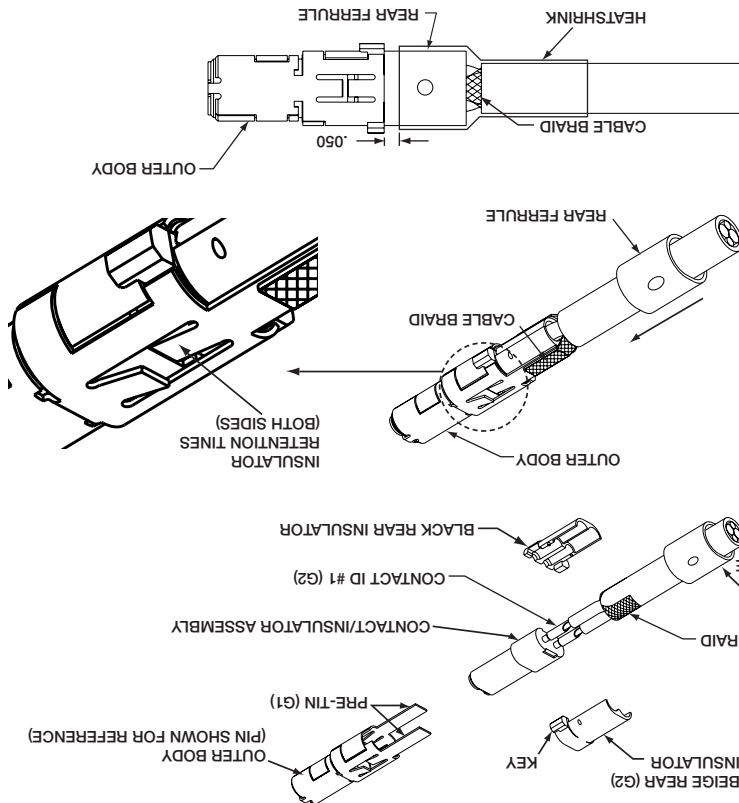

L-2119-FN
FSCM77820
November 2015

Contact Removal from Connector:
Remove Grommet/Backshell Assembly from rear of connector. Position removal tool part number 10-6460C1-001, around contact at connector mating face. Align removal tool tines with slots in connector insert then slide tool toward connector until tool tips come to a positive stop within the insert. Grip cable and gently pull cable from connector, simultaneously removing contact and cable. Remove tool from mating side of connector. Do not pull contact through grommet cavities, retention tines will damage grommet.

Contact Insertion into Connector:
Contacts are inserted by hand. Contact must be aligned with hole and not inserted at an angle. The contact's orientation key (the beige key) must be in alignment with the connector insert's orientation keyway. Push forward until contact is felt to snap into position within the insert. Gently tug on cable to assure retention. Once all contacts are installed in connector, attach grommet/backshell assembly to connector, aligning external key of backshell with the connector main key/keyway. (See images below)