

**Installation Instructions  
(General Insertion and Removal) for Size 20, 22, 22D & 22M.  
Power terminated cables.**

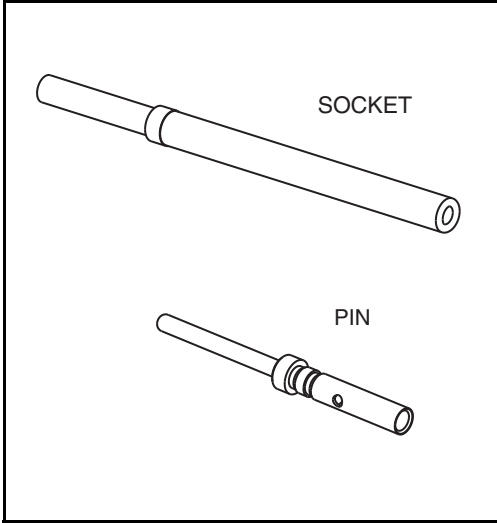

**Contact/Cable Insertion into Connector**

Contacts are inserted by hand. Insert the contact assembly into the proper rear grommet hole. Contact must be aligned with hole and not inserted at an angle.

**STEP 1**

Push forward using insertion tool (listed in table on back) until contact is felt to snap into position within the insert. While holding cable forward, remove tool.

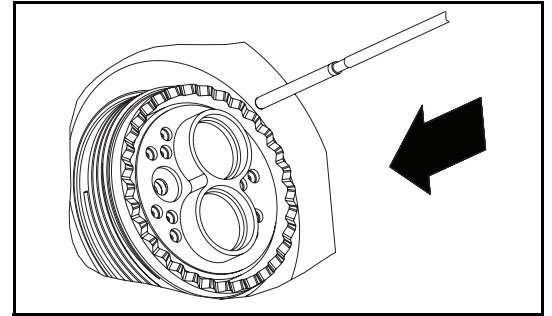

**STEP 2**

Gently tug on cable to assure retention.  
Continued on back of sheet.

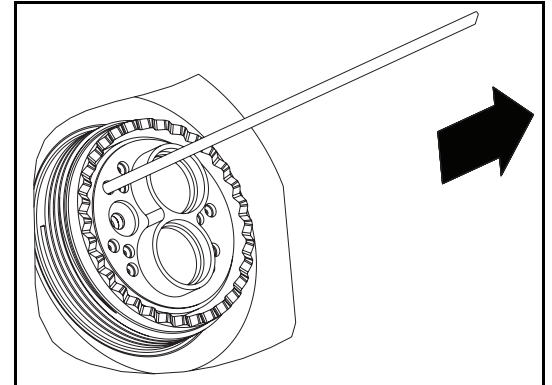

**Contact/Cable Removal from Connector**

Position removal tool (see table) around cable and slide tool toward connector until tool tips enter rear grommet and comes to a positive stop on the contact. Grip cable and simultaneously remove tool, contact and cable.

Tools Required		
Size	INSERTION	REMOVAL
20	M81969/14-10 or M81969/8-05	M81969/14-10 or M81969/8-06
22, 22D, 22M	M81969/14-01 or M81969/8-01	M81969/14-01 or M81969/8-02

---

**Amphenol**

Amphenol Aerospace  
40-60 Delaware Avenue  
Sidney, New York 13838-1395  
Website: [www.amphenol-aerospace.com](http://www.amphenol-aerospace.com)